



AMTRAK • AMTRAK • AMTRAK • AMTRAK

Long Distance **Product Features**

Issued March 2026

CONTENTS

COACH AREAS

1. Standard Coach
2. Premium Accessible Coach
3. Accessible Positions

SLEEPER BEDROOMS

4. Roomette
5. SoloSuite
6. Standard Bedroom
7. Accessible Bedroom

FOOD & BEVERAGE

8. Cafe Counter
9. Diner & Cafe Features
10. Lounge Features

TOILETS & SHOWERS

11. Accessible Toilet Room
12. Standard Toilet Room
13. Shower & Changing Room

COMMON USE AREAS

14. Entrance Areas
15. Interior Structures
16. Hallways



AMTRAK
CORPORATION
WASHINGTON, DC 20044

Coach Areas

- Sleeper Bedrooms
- Food & Beverage
- Toilets & Showers
- Common Use Areas

Amtrak® Long Distance Product Features

Coach Areas



25-F-010415 000000272 "UNCLASSIFIED" 4/2024

Coach Areas

- Sleeper Bedrooms
- Food & Beverage
- Toilets & Showers
- Common Use Areas

Amtrak® Long Distance Product Features

01 | Coach

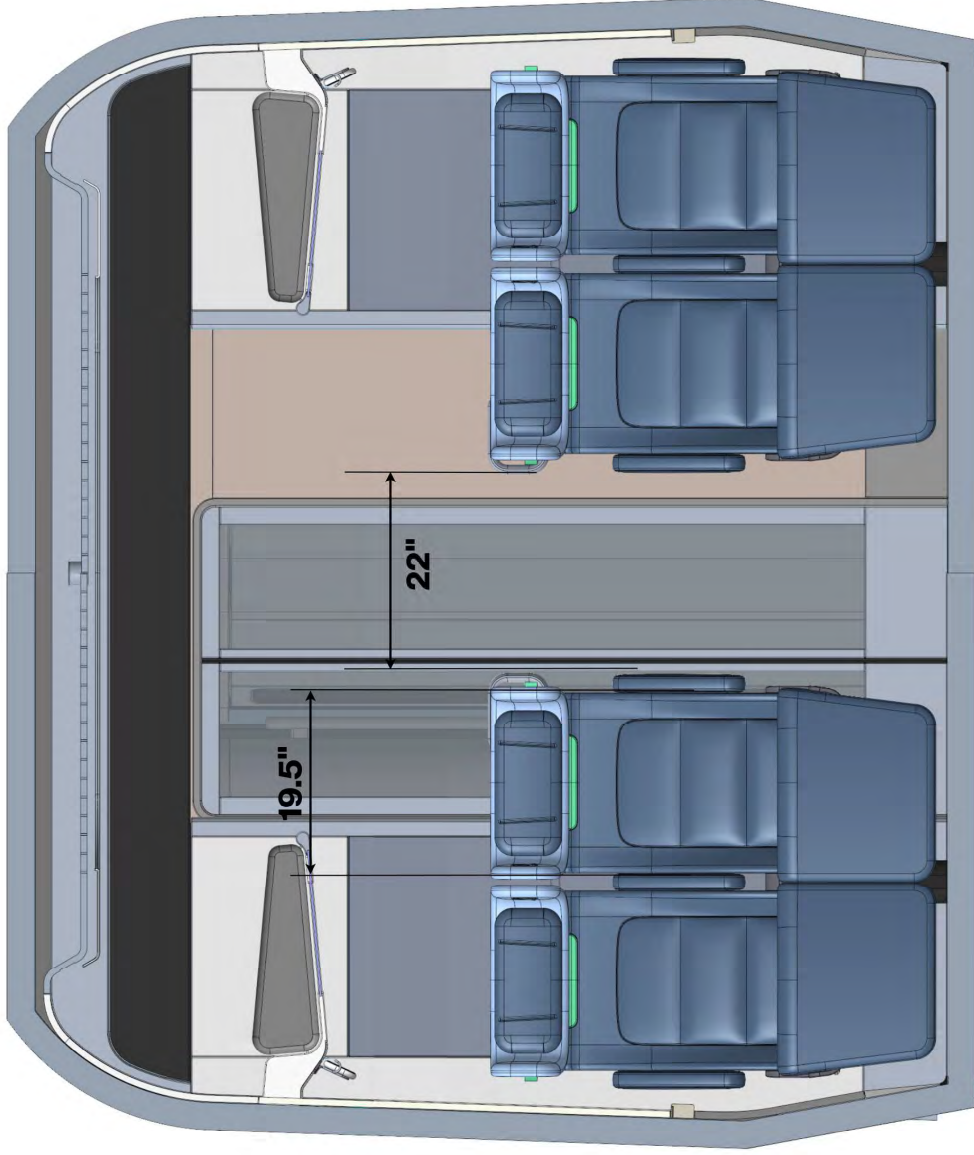

The Coach Seat

The coach seat is designed to work as pairs with four seats across the width of the train. The seat should be optimized for both day and night time operations.

Features should be included that aid a better night's sleep or support passengers on longer journeys by maximizing comfort and available passenger space.

The minimum width of the seat between armrests should be 19.5" when arranged with a minimum aisle dimension of 22".

A single seat option may also be required in smaller numbers to accommodate transfer seats and fulfill requirements around accessible paths in our accessible coach car.

Coach Seat | General

Seat Dimensions

All seat dimensions, cushion density/shore hardness will be subject to mockup review, a detailed human factors study and approval by Amtrak.

25-PD-0416 000004272 UNCLASSIFIED 4/20/24

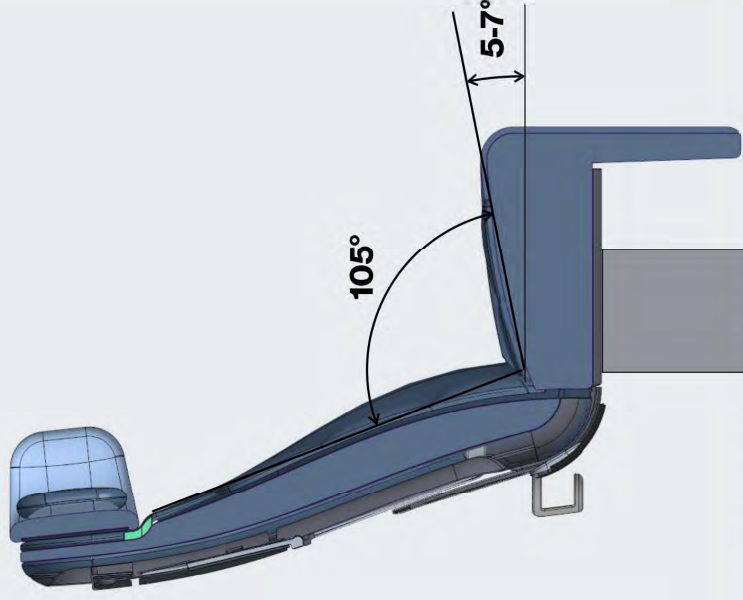
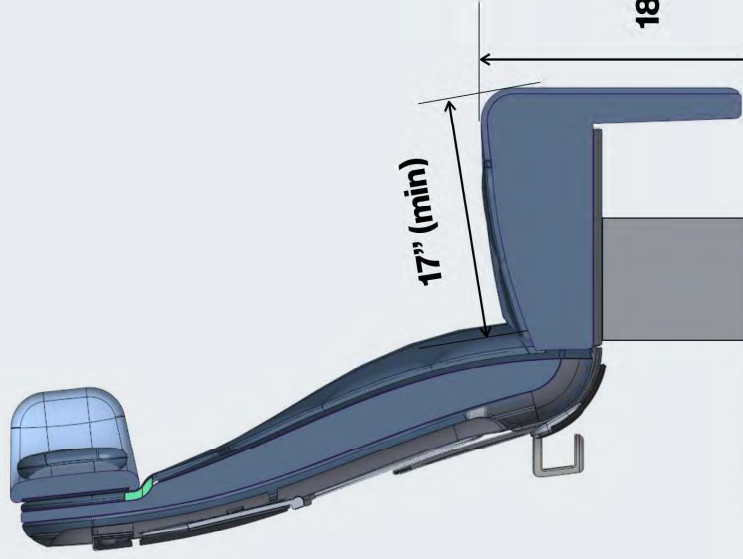



25-FD-0415 000004272 "UNCLASSIFIED" 4/2/2014

Coach Seat | Features

Coach Seat | Features

26-FD-0416 000004272 "UNCLASSIFIED" 4/20/2016

Headrest Pillow

Headrest pillow should be adjustable in height for a range of people sizes. It should have adjustable wings that fold outwards to adjust the width of the headrest.

Privacy Wing

Privacy wing on the seats should provide good separation between passengers at head level.

Seat Comfort

Seat cushions are contoured to aid seat comfort. Detailing will be evaluated and judged carefully during the design review process and will be subject to Amtrak approval.

Hand Grab

Every aisle seat should have a compliant accessible grab for better access along the aisle.

Reading Light

Positioned so as not to disturb neighbors during night time hours. Passengers should be able to adjust the lighting angle to cast light over the shoulder. Light intensity should have three settings.

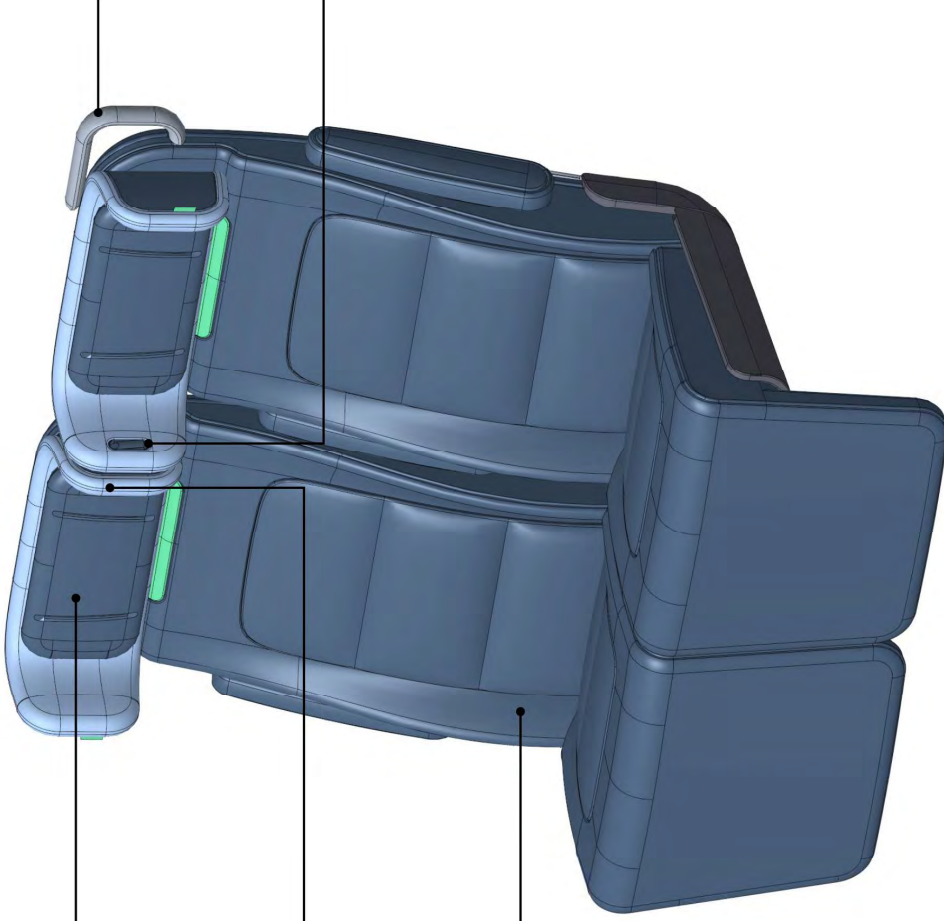

Coach Seat | Features

26-FD-0416 000004272 "UNCLASSIFIED" 4/20/2016



20° Recline
The seat should have a minimum seat recline angle of 20 degrees.

Folding Armrests
2" wide armrest with a soft wrap around the top for comfort, and a hard-wearing bottom wrap and side cap for durability.

Calf Rest Pad
Calf rests tilt up for optimal leg support and comfort. The calf rest should be integral to the seat pan to avoid seat pinch.

Seat Controls
Seat controls for recline and leg rest should be located within easy reach of a customer. It should be possible to control the seat back recline and the calf rest independently.

Seat Recline Mech
Seat recline mechanism should allow the seat pan to slide forwards so as not to burden the full recline onto the passenger behind.

Coach Seat | Features

25-FD-0416 000004272 "UNCLASSIFIED" 4/20/2016

Clean, Tidy Seat Back
The back of the seat should be designed to have an integrated appearance.

Flexible Pocket
A stowage pocket should be provided on the back of the seat.

Central Foot Pedestal
A central seat pedestal should be positioned to maximize foot clearance.

On-seat Power
Two USB ports should be provided on the back of each of the seats.

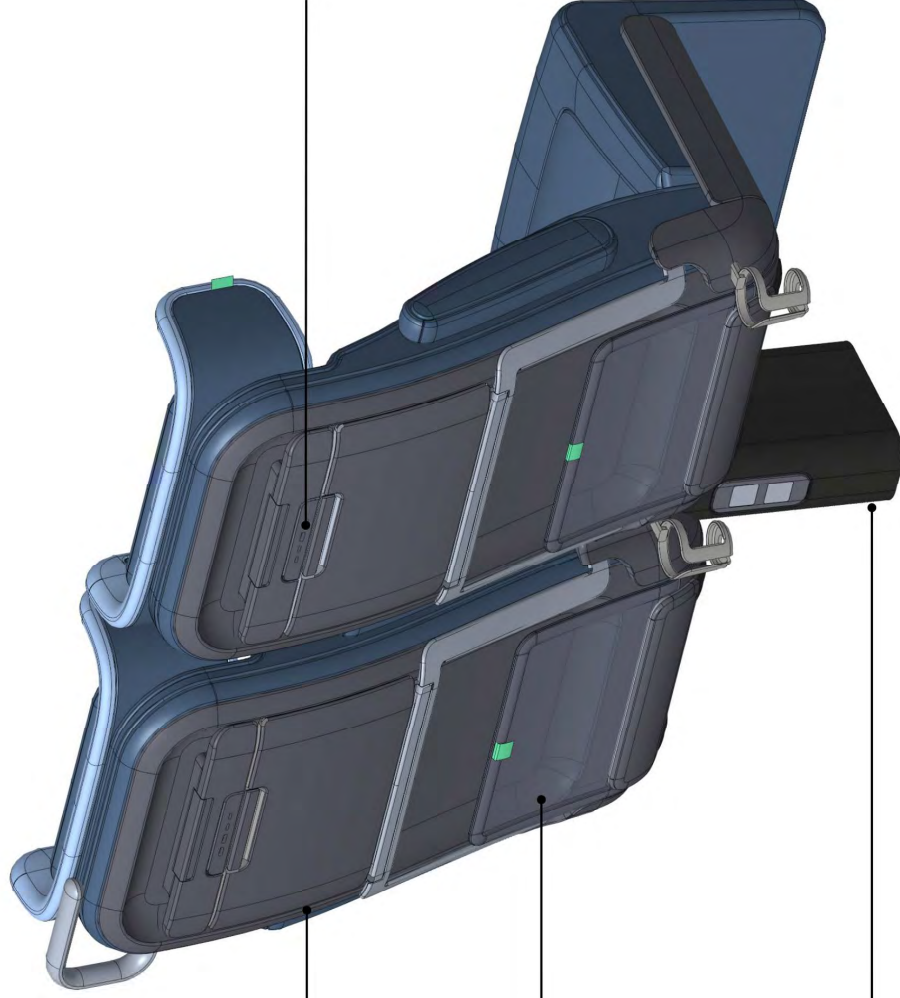

Coach Seat | Features

25-FD-0416 000004272 "UNCLASSIFIED" 4/20/2016

Stowage Lectern
Behind the fold down table a lectern edge and elastic restraint band suitable to allow customers to simply stow smart phones and other personal items behind table.

Fold out Table
A fold out table should have an independent pivot point so that its resting position will not be impacted by the recline of the seat in front.

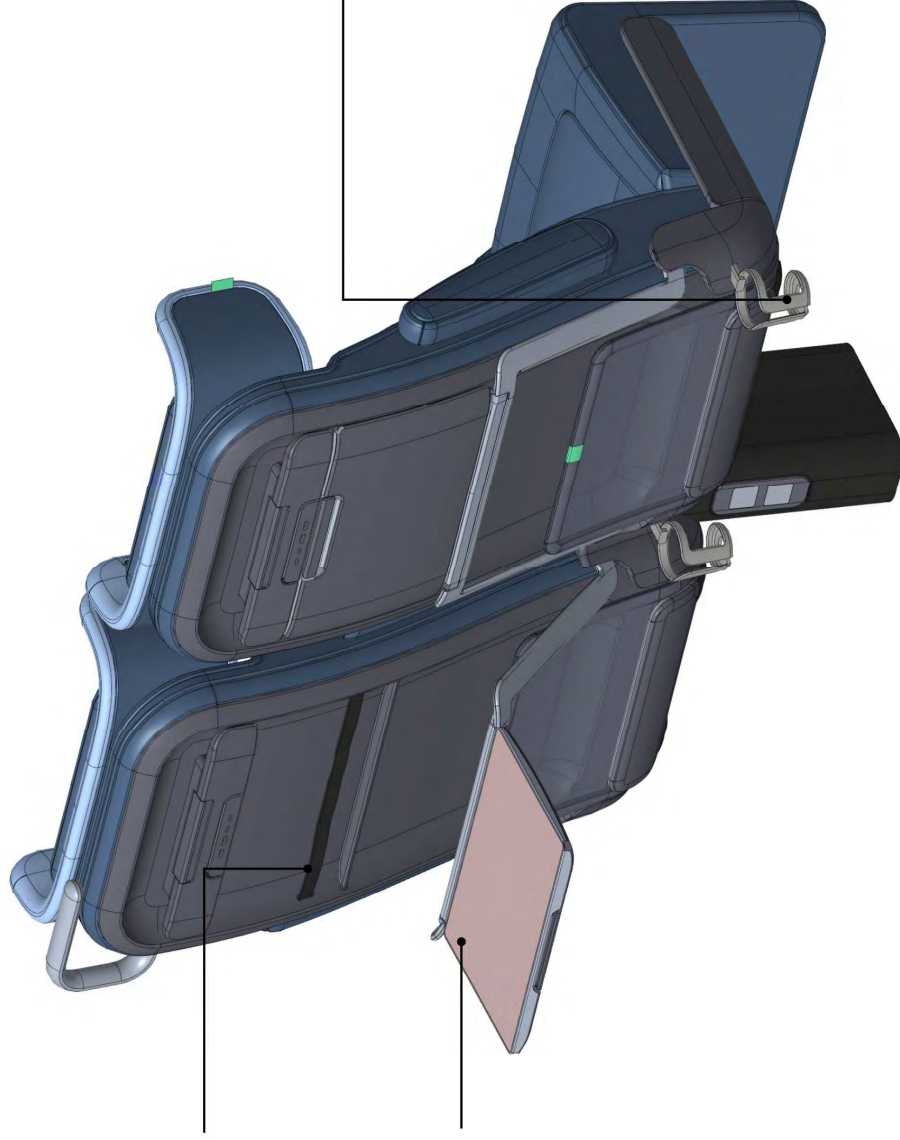

Cup Holders

A metal cup holder should be positioned on the back of the seat. Cup holders should be placed in positions outside of knee and leg clearance and free from the movement of the seat.

Coach Seat | Features

25-PJ-04115 0000004272 "UNCLASSIFIED" 4/20/2016

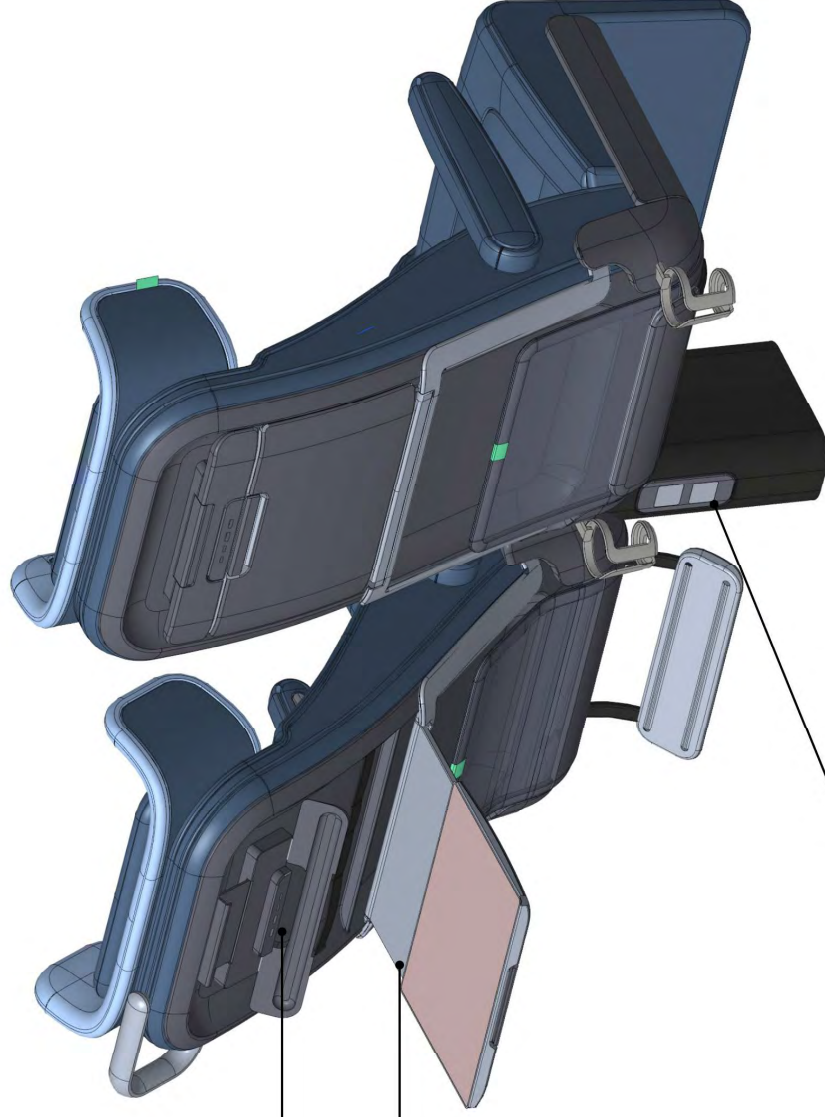

Device Holder

A fold out lectern edge with clip should allow the secure mounting of passengers' personal devices. The angle should be set so it is usable in both recline and upright positions.

Folding Table Extension

The table should be able to extend forwards telescopically. The usable surface should allow people to use a 15" laptop even when seat is fully reclined.

Fold-out Footrest

A fold-out adjustable footrest should be provided. There should be three set positions and the footrest should have a degree of angle adjustment.

Power Socket

Two power sockets should be located on the seat pedestal.

Coach Seat | Features

25-P-01-0416 0000004272 "UNCLASSIFIED" 4/20/2016

Seat Dimensions

All seat dimensions, cushion density/shore hardness will be subject to mockup review and approval by Amtrak.

Knee Clearance

Seats set at a 42" pitch must provide at least 7" knee clearance and at least 2" of feet clearance for a 95th percentile male in the seat's worst case scenario - i.e. when both seats are reclined.

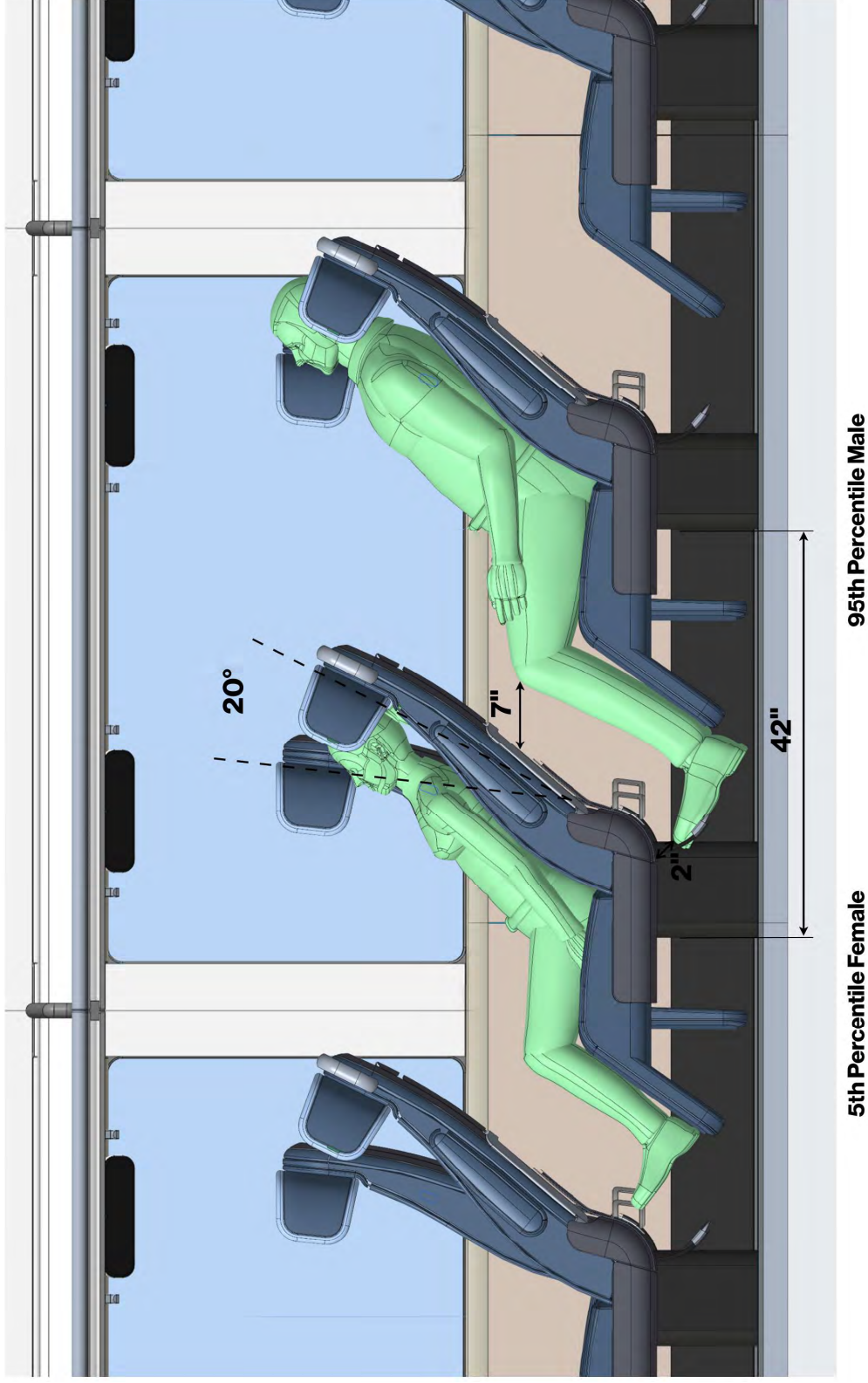

5th Percentile Female

95th Percentile Male



3547010416 0000002772 "UNCLASSIFIED" 4/20/2014

Coach Areas

- Sleeper Bedrooms
- Food & Beverage
- Toilets & Showers
- Common Use Areas

Amtrak® Long Distance Product Features

02 | Premium Coach

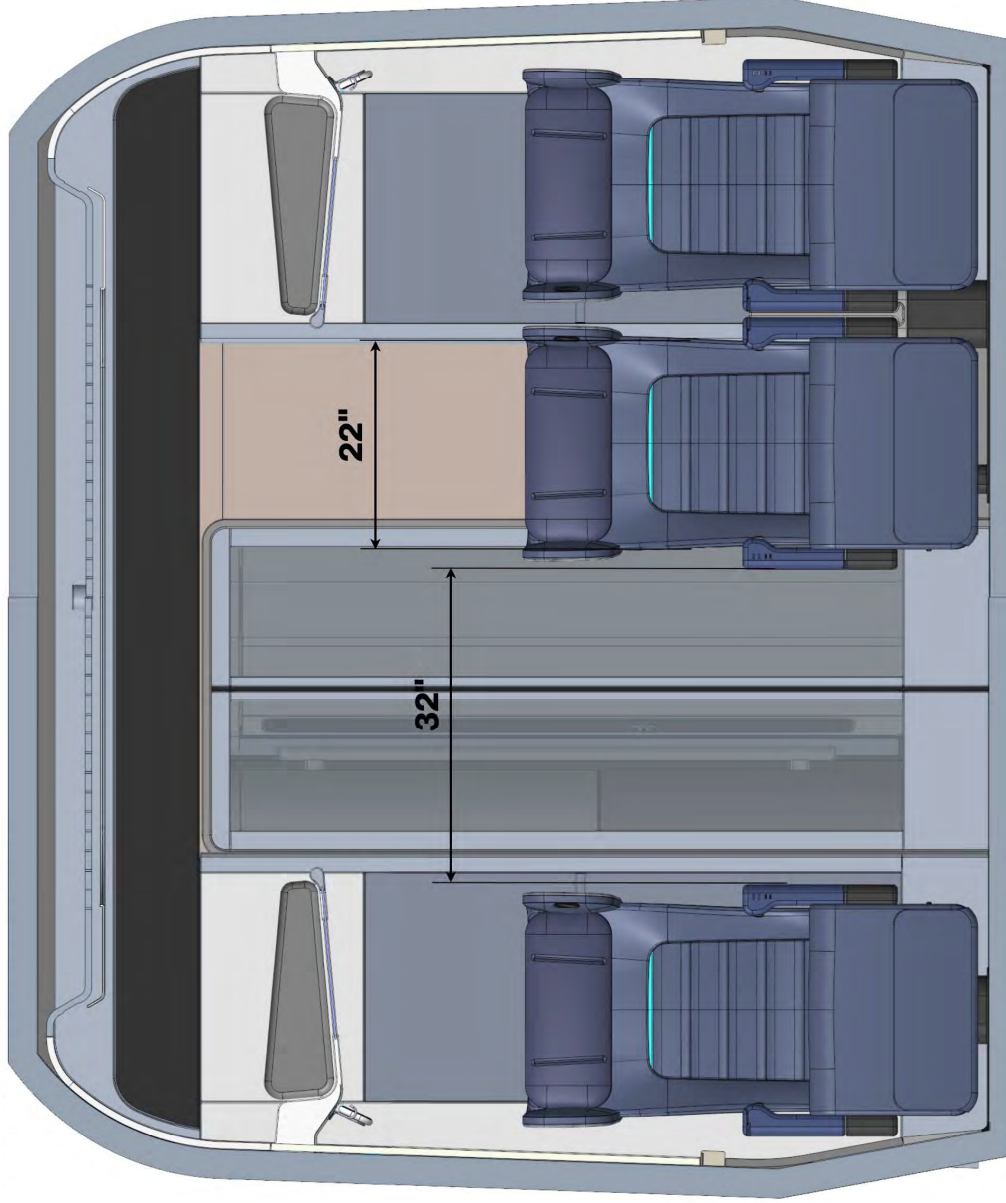

The Premium Coach Seat

The Premium Coach seat is designed as an elevated coach product. The seat can be arranged 2x1 across a 32" accessible aisle. The seat should be optimized for both day and night time operations.

All features should be optimized to provide a better night's sleep, maximizing comfort and the available space to support passengers on longer journeys.

The minimum width of the seat between armrests should be 22" when arranged with a 32" aisle.

Premium Coach Seat | General

25-PD-0416 000004272 "UNCLASSIFIED" 4/20/24

Seat Dimensions

All seat dimensions, cushion density/shore hardness will be subject to mockup review and approval by Amtrak.

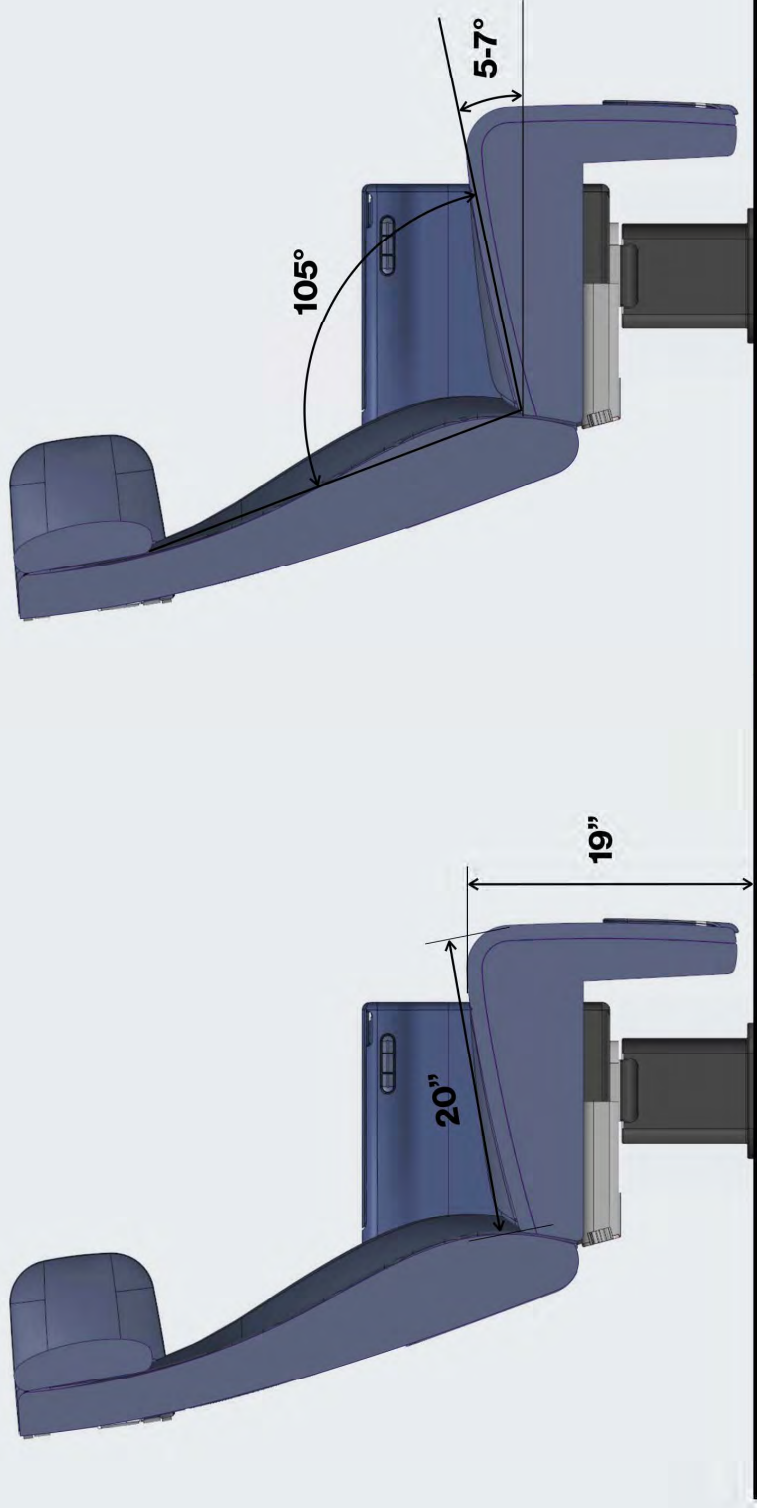

DRAWINGS NOT TO SCALE

Premium Coach Seat | General

25-FD-0416 000004272 UNCLASSIFIED 4/20/24

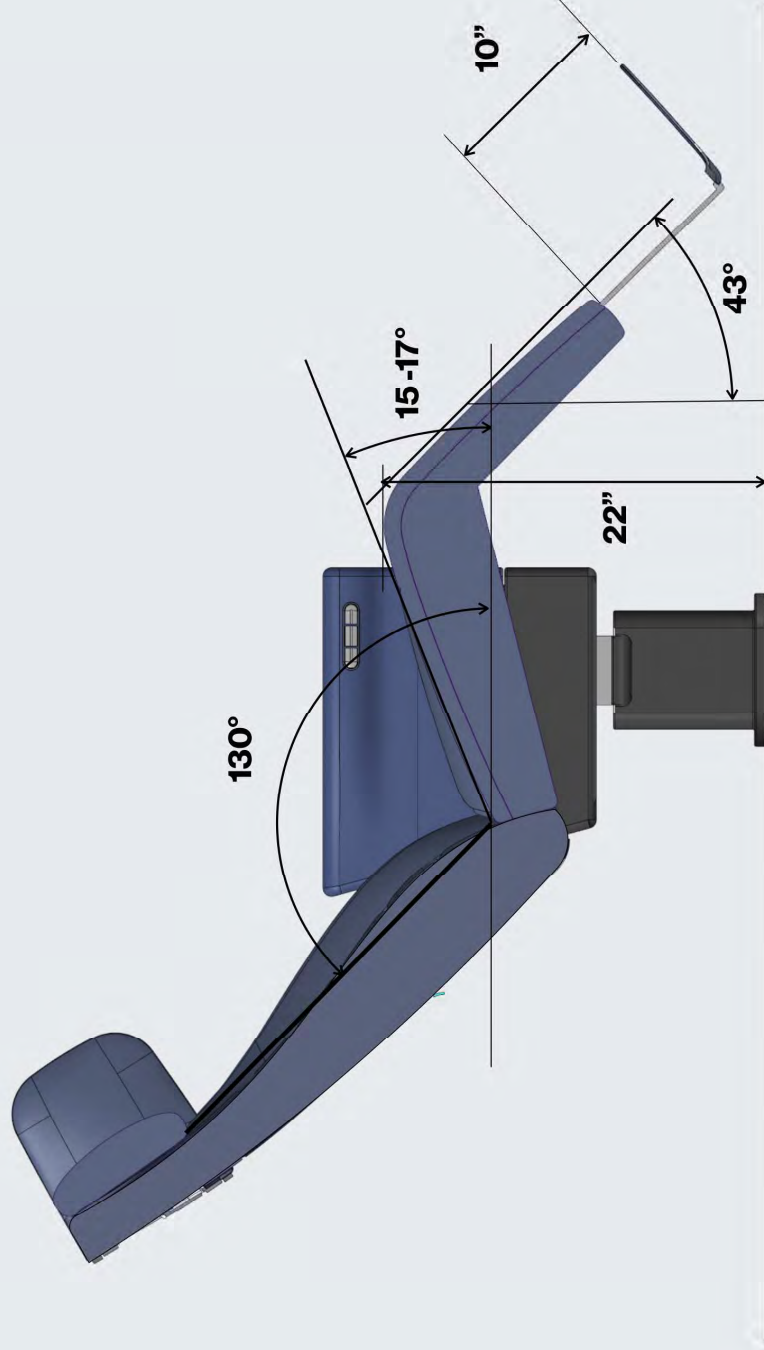

Lazy Z

The Premium Coach Seat has a 25° recline. Importantly the seat pan should also change angle with the recline by 10° lifting the knees upwards to create a cradle position. An adjustable calf rest angle of 43° supports the legs while a flip out foot rest with a telescopic movement of 10" supports the feet.

The seat should be optimized to maximize foot and leg clearance at a 48" pitch.

DRAWINGS NOT TO SCALE

Premium Coach Seat: | General

25-FD-10416 000000272 "UNCLASSIFIED" 4/20/2016

Rotating Seat Mechanism

The seat should rotate with the seat pan moving past the side wall when the seat is fully upright. The pivot location should be positioned in such a way to maximize the width of the seat and provide an optimized arrangement of the seats in both directions.

Rotating Seat Pedestal

The pedestal size and position should be designed to maximize foot space and space for small bags under the seat. The design under the seat should be free from protrusions and snag points and be easy to clean around the pedestal

Release Pedal

A foot release pedal should unlock the seat ready for rotation.

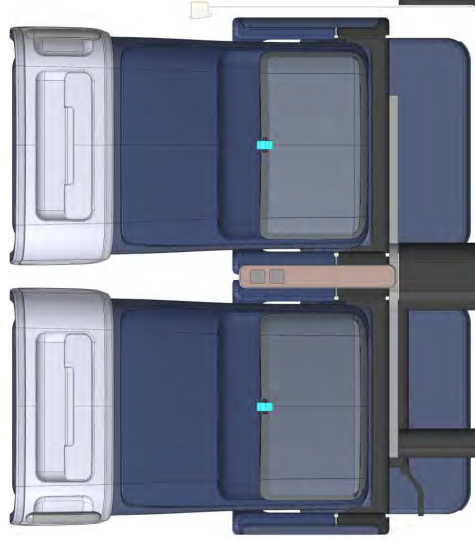

0° Rotation

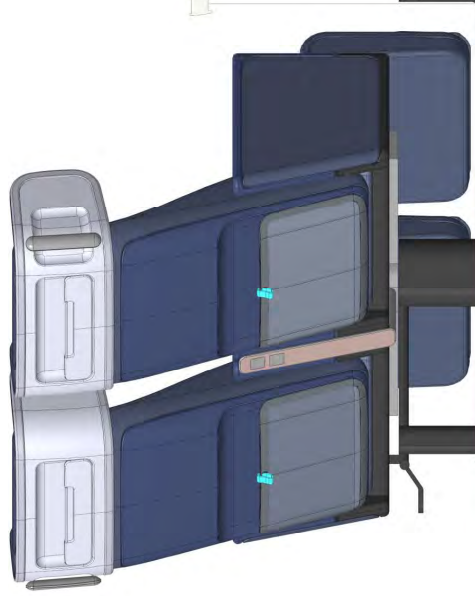

45° Rotation

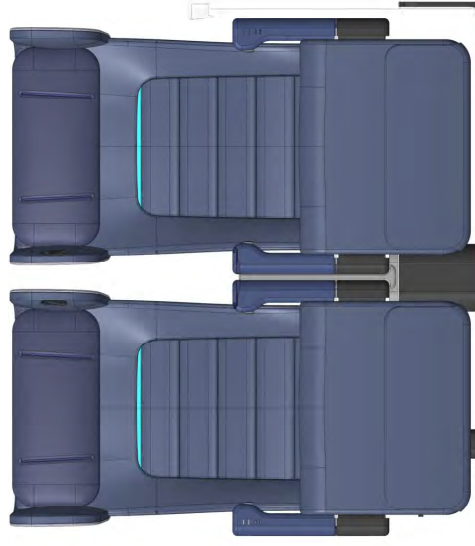

180° Rotation



26-FD-0416 000004272 "UNCLASSIFIED" 4/20/24

Premium Coach Seat | Features

Premium Coach Seat | Features

26-FD-10416 0000004272 "UNCLASSIFIED" 4/20/2016



Privacy Wing
Wide privacy wing should offer good separation between passengers at head level.

Headrest Pillow
Headrest pillow should be adjustable in height for a range of people sizes and have adjustable wings that fold outwards to adjust the width of the headrest.

Seat Controls
Seat controls for recline and leg rest should be located within easy reach of a customer. It should be possible to control the seat back recline and the calf rest independently.

Reading Light
Positioned so as not to disturb seat neighbor during night time hours. Passengers should be able to adjust the lighting angle. Light intensity should have three settings.

USB ports
On seat USB ports to charge mobile devices should be in the armrest of each seat.

Premium Coach Seat | Features

25-F-010416 0000004272 "UNCLASSIFIED" 4/20/2016

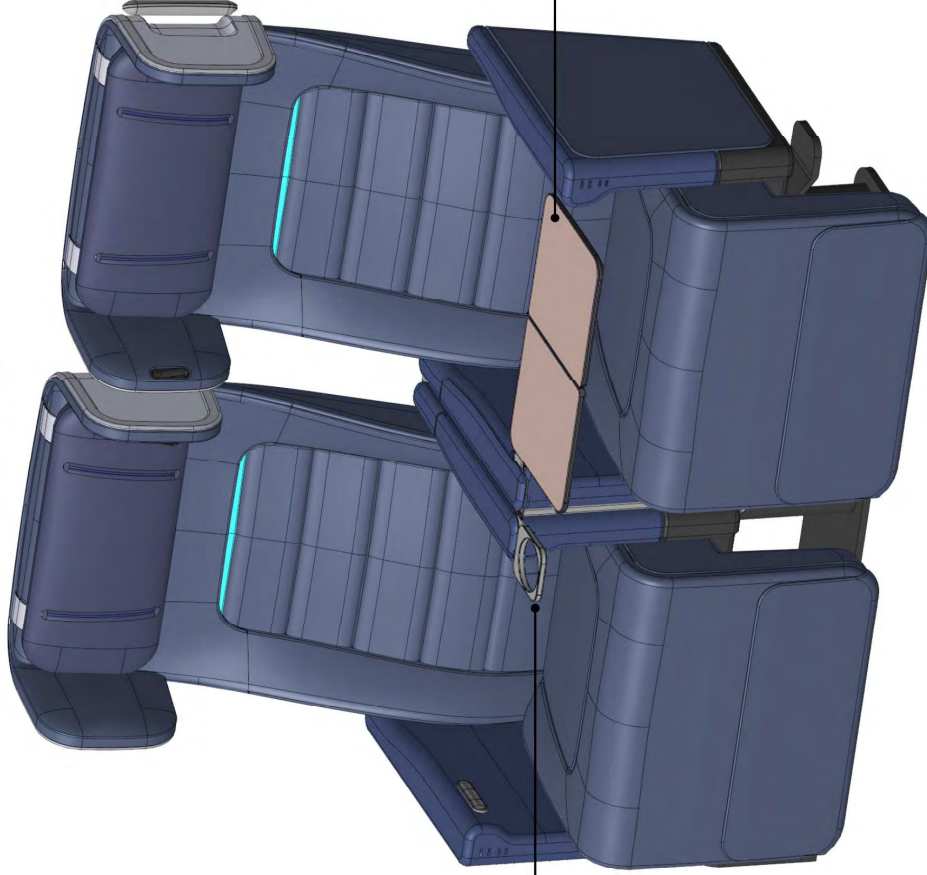

Cup Holders
A fold out metal cup holder on each seat should be deployed from the central console.

Fold Out Table

An airline style bi-fold table should deploy from central console. The usable surface should allow people to use at least a 15" laptop. The table should also be able to track forward and back when deployed.

Premium Coach Seat | Features

25-F-01-0416 0000004272 "UNCLASSIFIED" 4/20/2016

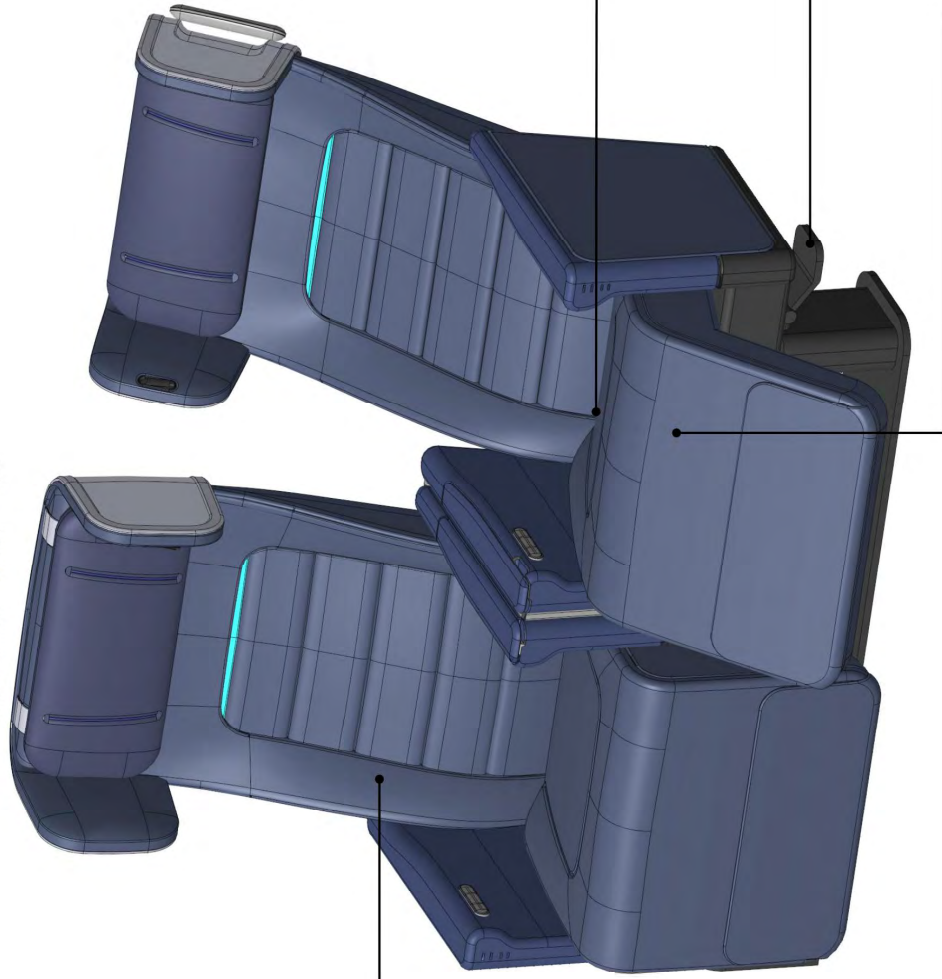

Seat Comfort
Seat cushions are contoured to aid seat comfort.

Lazy Z
The seat must achieve a Lazy Z position.

Rotating Seat Pedal

Seat Mechanism
Seat mechanism should be easy to use by people of all abilities.

Premium Coach Seat | Features

25-PF010416 0000004272 "UNCLASSIFIED" 4/20/2016

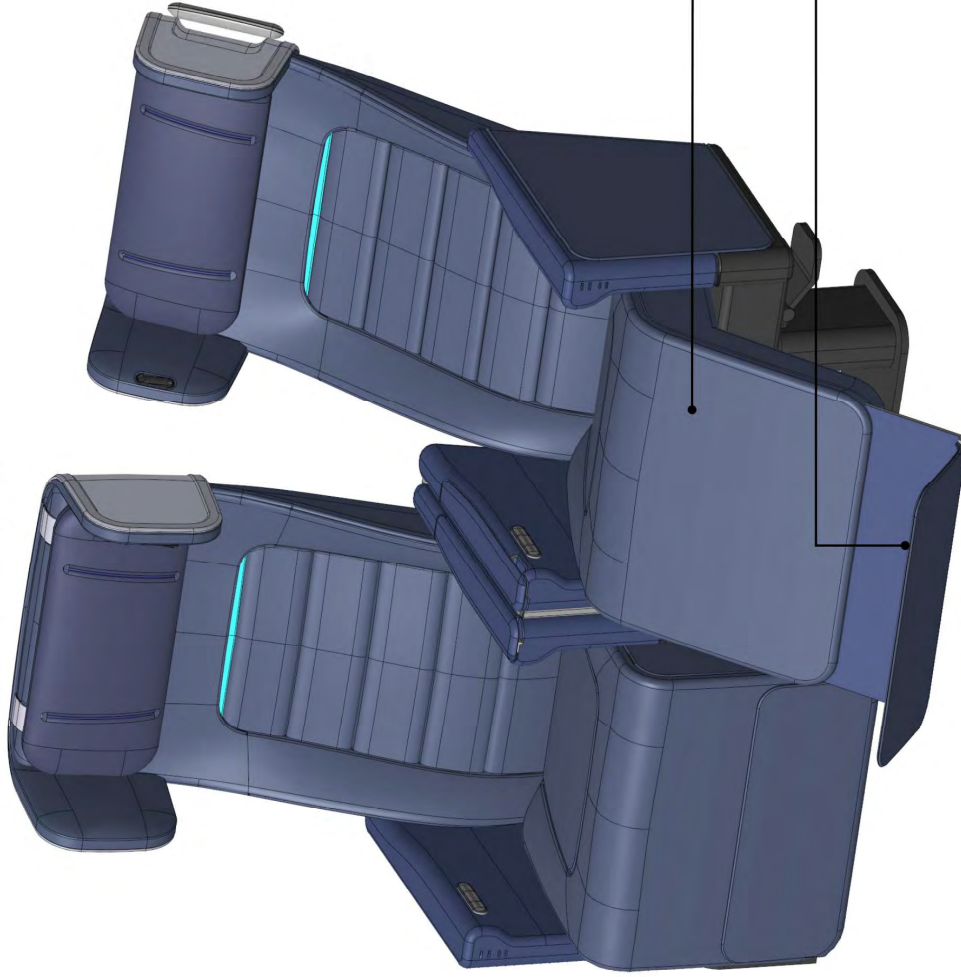

Calf Rest Pad

Calf rest must be independently controlled from the Lazy Z recline.

Foot rest

Each seat has fold out, telescopic foot rest to increase seat comfort.

Premium Coach Seat | Features

25-F-01-0416 0000004272 "UNCLASSIFIED" 4/20/2016



Slide Down Armrest

The aisle armrest must move to provide an unobstructed approach to the seat pan so a person using a wheelchair can complete a successful side transfer.

Premium Coach Seat | Features

26-FD-0416 000004272 "UNCLASSIFIED" 4/20/2016



Clean, Tidy Seat Back
The back of the seat should be designed to have an integrated appearance.

Hand Grab
Seats should have a compliant accessible grab on both sides of the seat pair and on both sides of the single seat for better access along the aisle regardless of the seat rotation condition.

Power Socket
Two power sockets should be located on the seat pedestal.

Flexible Pocket
A storage pocket should be provided on the back of the seat.

Premium Coach Seat | Features

25-FD-0416 000004272 "UNCLASSIFIED" 4/20/2016



Device Holder
A fold out lectern edge with clip should allow the secure mounting of passengers' personal devices. The angle should be set so it is usable in both recline and upright positions.

Premium Coach Seat | Features

25-F010416 0000004272 "UNCLASSIFIED" 4/20/2016

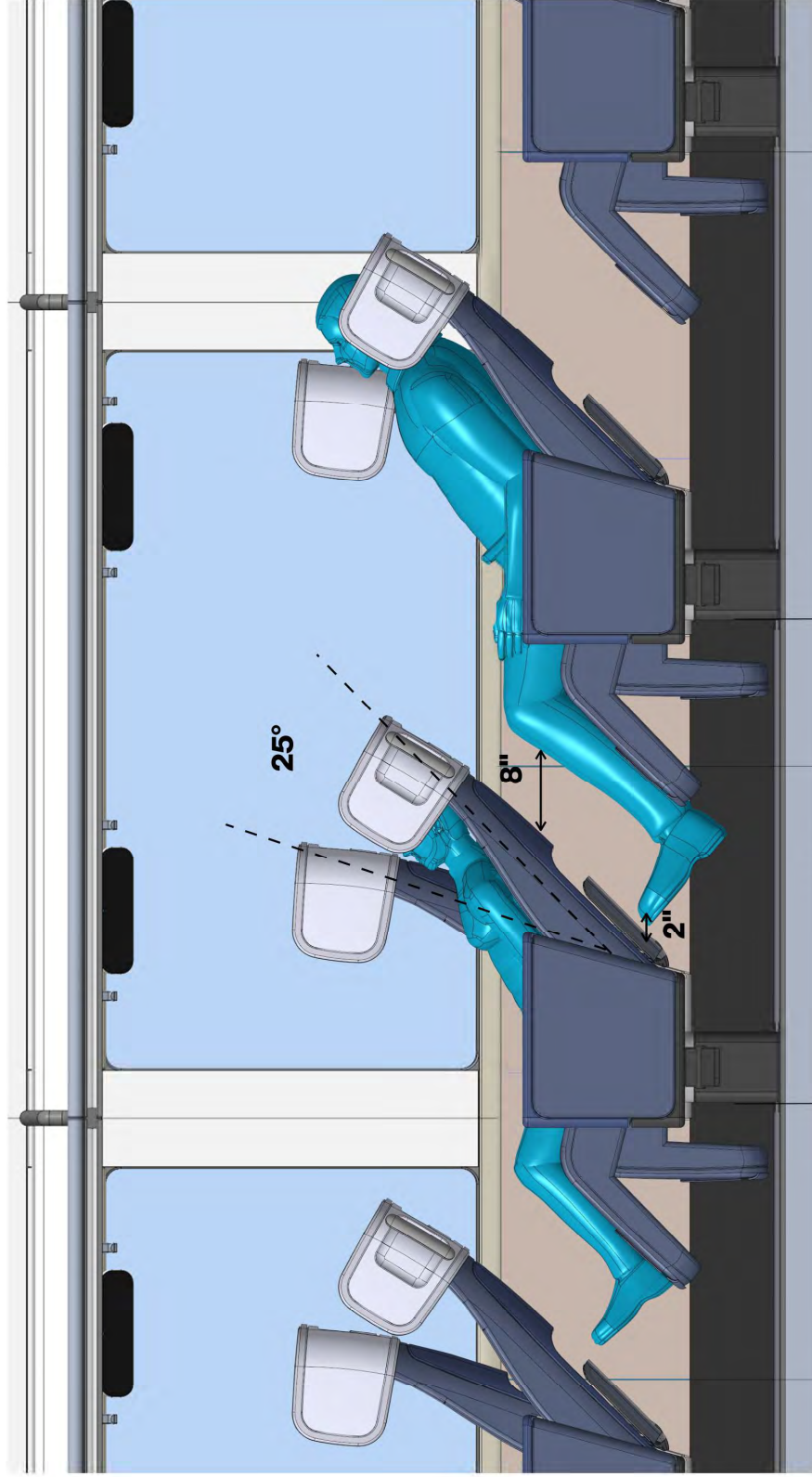

Seat Dimensions

All seat dimensions, cushion density/shore hardness will be subject to mockup review and approval by Amtrak.

Knee Clearance

Seats set at a 48" pitch must provide at least 8" knee clearance for a 95th percentile male in the seat's worst case scenario - i.e. when both seats are reclined.

Feet Clearance

Seats set at a 48" pitch must provide at least 2" of feet clearance for a 95th percentile male with the footrest and seat at its most reclined and most extended condition.



25-F01-0415 000004272 "UNCLASSIFIED" 4/20/24

Coach & Premium Coach | Lighting

Coach and Premium Coach | Lighting

26-FD-0416 000004272 "UNCLASSIFIED" 4/20/2016



Under Seat Lighting
Indirect wash lighting under each seat or seat pair washes pools of light under and around seat. Spread of light to be approved by Amtrak.



25-F-010416 000000272 "UNCLASSIFIED" 4/2024

Coach Areas

- Sleeper Bedrooms
- Food & Beverage
- Toilets & Showers
- Common Use Areas

Amtrak® Long Distance Product Features

03 | Accessible Positions

Coach and Premium Coach | General

25-F010416 0000004272 "UNCLASSIFIED" 4/20/2014

Accessibility

All accessible spaces, turning circles and transfer seats will be subject to mockup review, user testing and approval by Amtrak.

Transfer Seats

Transfer seats shall have an RVAAC. Accessible space allowance so people who choose to transfer from their wheelchairs to a seat have free and easy access to complete this maneuver.

Folded Wheeled Mobility Device Storage

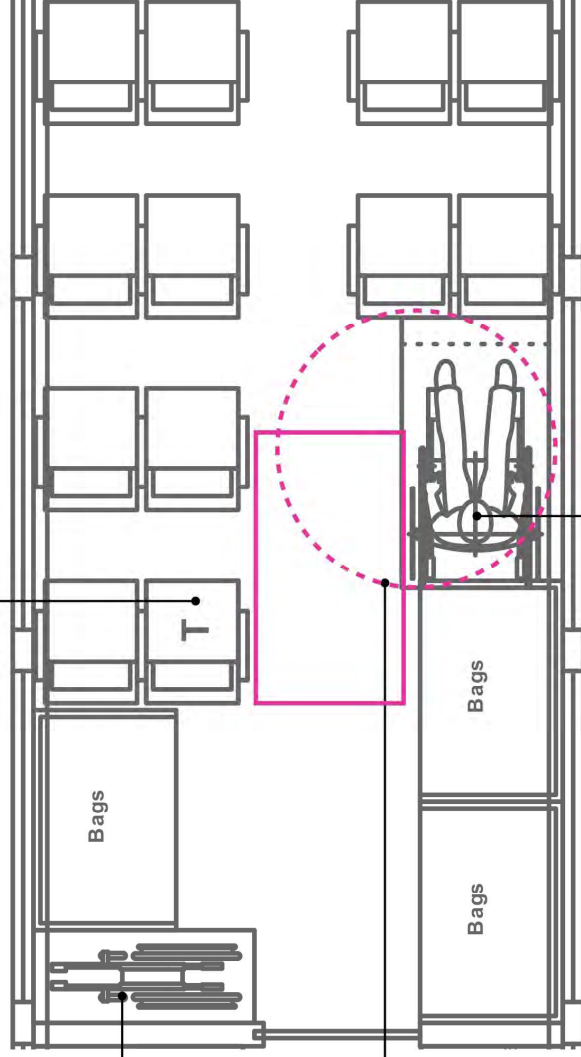

60" Turning Circles

60" turning circles should be provided at each accessible space per ADA and RVAAC guidelines.

First Row Seating

First row seating should have the same provisions and features as all other seats, including at seat power, stowage pockets, tables and footrests. In the case of rotating seats these shall be provisions at both ends of the cars so features are accessible in both seating orientations.

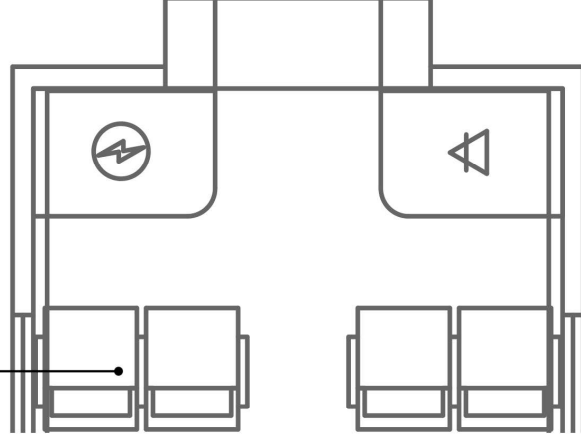

Accessible Spaces

Accessible spaces should have the same provisions and features as all other seats, including at seat power, stowage pockets and tables. Accessible spaces should be protected in the case of rotating seats. A short partition should be provided that gives an option for wheelchair restraints. Accessible spaces should allow passengers to have a choice in direction of travel.



REPORTS 80006273 UNCLASSIFIED #2024

Coach Areas

Sleeper Bedrooms

Food & Beverage

Toilets & Showers

Common Use Areas

Amtrak® Long Distance Product Features

Sleeper Bedrooms



25-F-010416 000000272 "UNCLASSIFIED" 4/2024

Coach Areas
Sleeper Bedrooms
Food & Beverage
Toilets & Showers
Common Use Areas

Amtrak® Long Distance Product Features

04 | Roomette



25-FOI-0416 000004272

"UNCLASSIFIED"

4/20/24

Roomette | Features

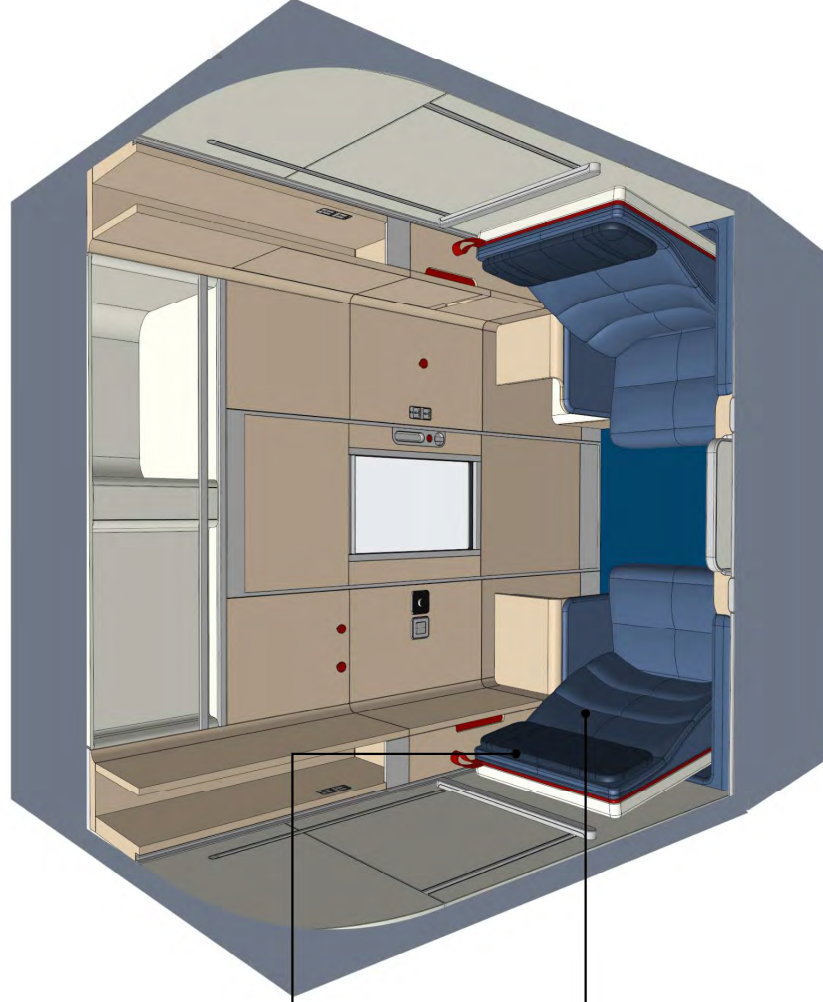

Seat Headrests

Seat headrest should be adjustable in height for a range of people sizes and have adjustable wings that fold outwards to adjust the width of the headrest.

Seat Comfort

Seat cushions should be contoured to aid seat comfort.



Seat Dimensions
A minimum seat width between inside surfaces of armrests should be a minimum of 26".

Armrest
A full and cushioned armrest of 3.5" should be provided on the window side. The armrest should be of a suitable length for a seated passenger to rest their forearm on the cushioned section.

Seat side pad
A soft seat side pad is required on the inside side of the seat to balance the seat and allow some cushioning to the inside edge to soften joining panel work

Cup Holders
One for each passenger, located so people can use and access the cupholders from a seated position. Cup holders should be able to fold away when not.

Fold out Table
Single leaf table deployed from side wall. The table height should provide good knee clearance for seated people with a height of the finished floor between 27" and 29". The table should be easy to deploy and stow with an intuitive handle.

Seat Dimensions
All seat dimensions, cushion density/ shore hardness will be subject to mockup review and approval by Amtrak

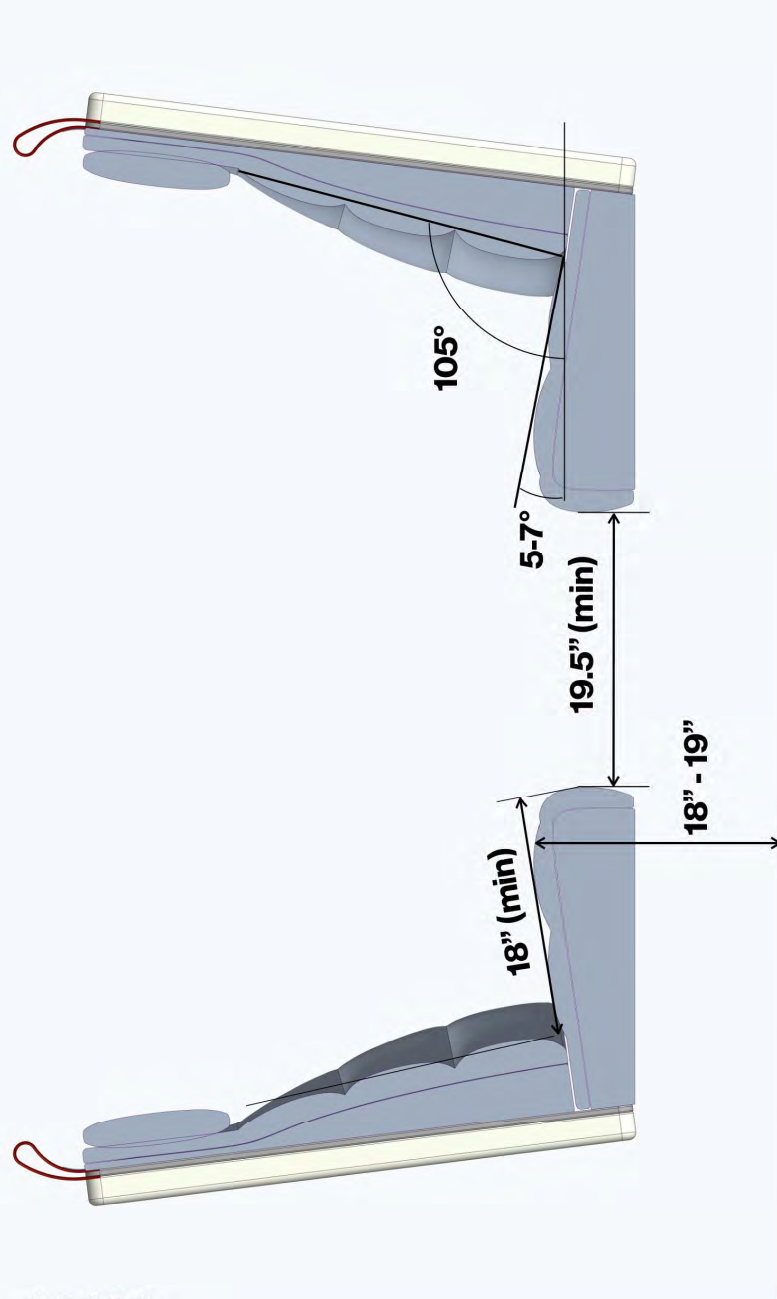

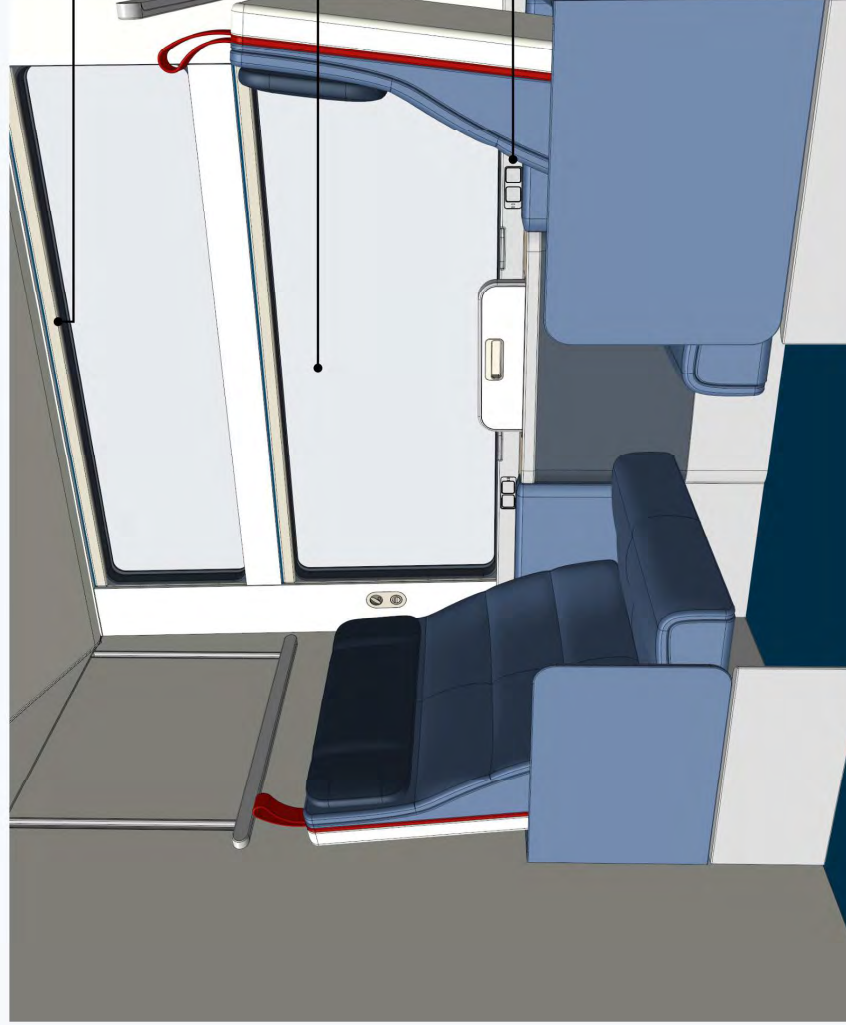

Blinds

A single pull-down blind system shall be provided per window, capable of delivering both daytime solar/glare control and full blackout performance.

Window and Window Mask

Window and window mask should be central to the room and overall window size maximized.

At Seat Power

Two power sockets and two USB sockets should be provided to each seated location. The position should be above the armrest height and in easy reach of people while seated.

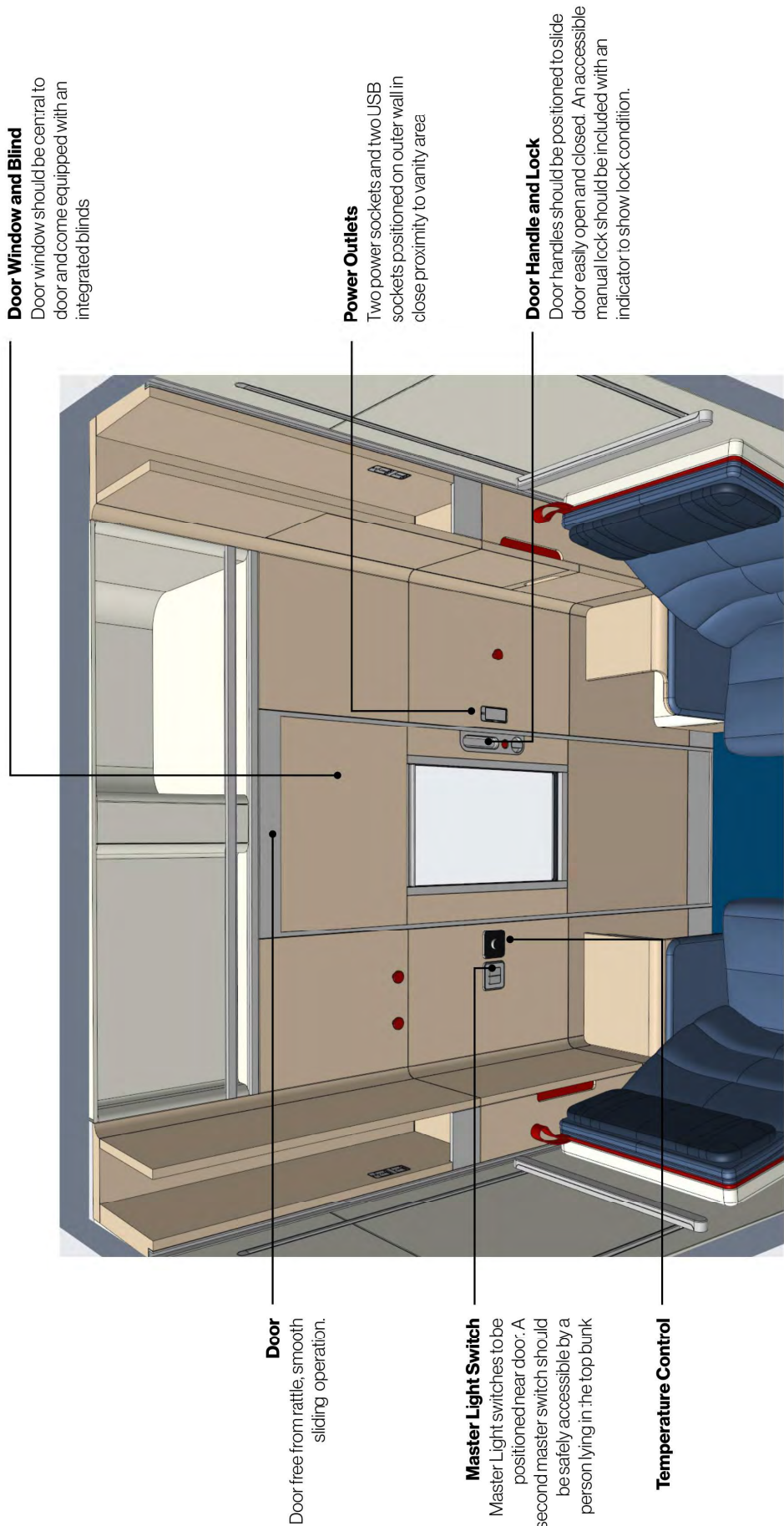

Door
Door free from rattle, smooth sliding operation.

Master Light Switch
Master Light switches to be positioned near door. A second master switch should be safely accessible by a person lying in the top bunk

Temperature Control

Door Window and Blind
Door window should be central to door and come equipped with an integrated blinds

Power Outlets
Two power sockets and two USB sockets positioned on outer wall in close proximity to vanity area

Door Handle and Lock
Door handles should be positioned to slide door easily open and closed. An accessible manual lock should be included with an indicator to show lock condition.

Roomette | Features

26-FD-10416 000000272 "UNCLASSIFIED" 4/20/2016

40

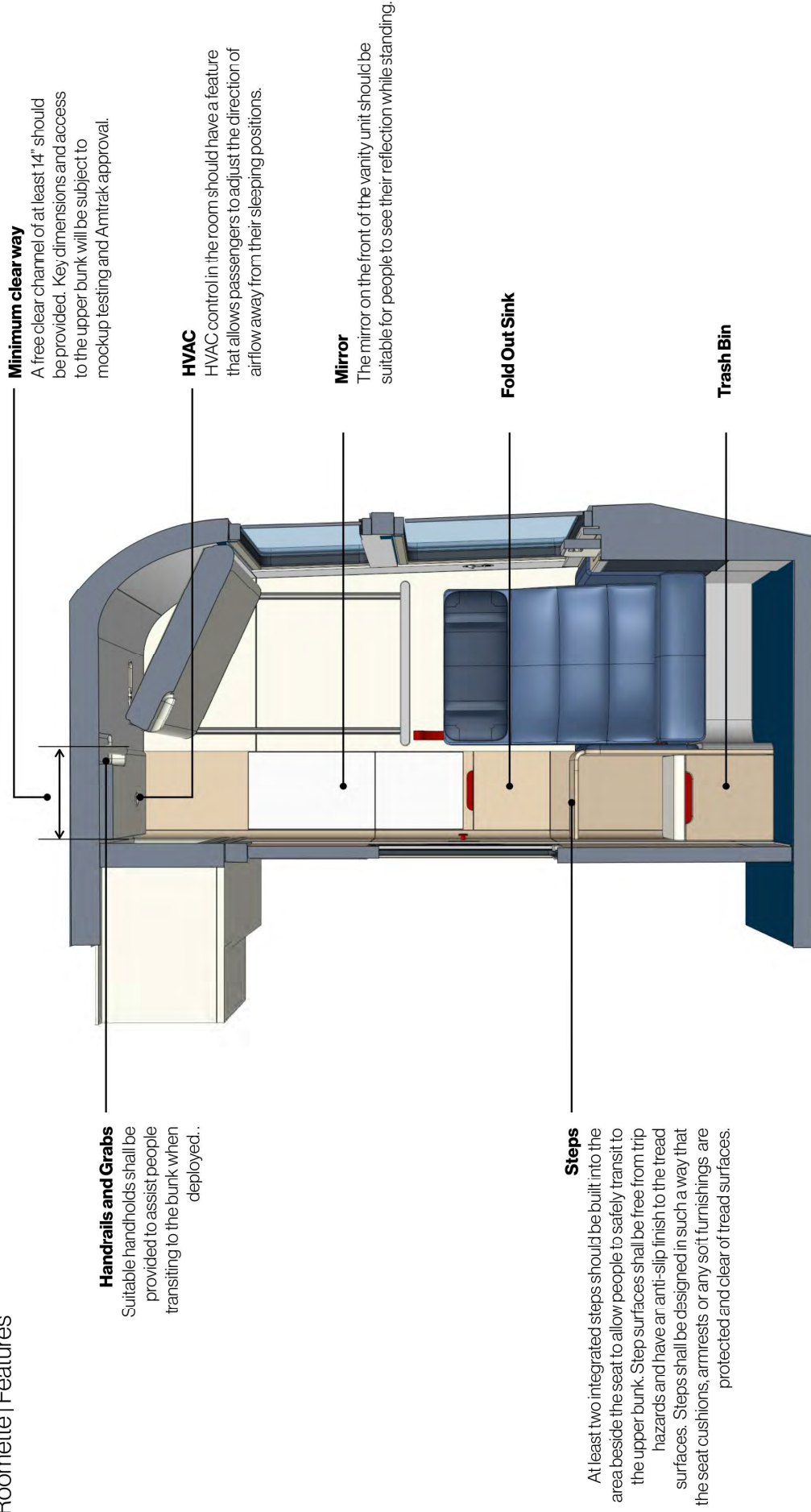

Handrails and Grabs

Suitable handholds shall be provided to assist people transiting to the bunk when deployed..

Minimum clear way

A free clear channel of at least 14" should be provided. Key dimensions and access to the upper bunk will be subject to mockup testing and Amtrak approval.

HVAC

HVAC control in the room should have a feature that allows passengers to adjust the direction of airflow away from their sleeping positions.

Mirror

The mirror on the front of the vanity unit should be suitable for people to see their reflection while standing.

Fold Out Sink

Trash Bin

Steps

At least two integrated steps should be built into the area beside the seat to allow people to safely transit to the upper bunk. Step surfaces shall be free from trip hazards and have an anti-slip finish to the tread surfaces. Steps shall be designed in such a way that the seat cushions, armrests or any soft furnishings are protected and clear of tread surfaces.



25-FOI-0416 000004272

"UNCLASSIFIED"

4/20/24

Roomette | Storage

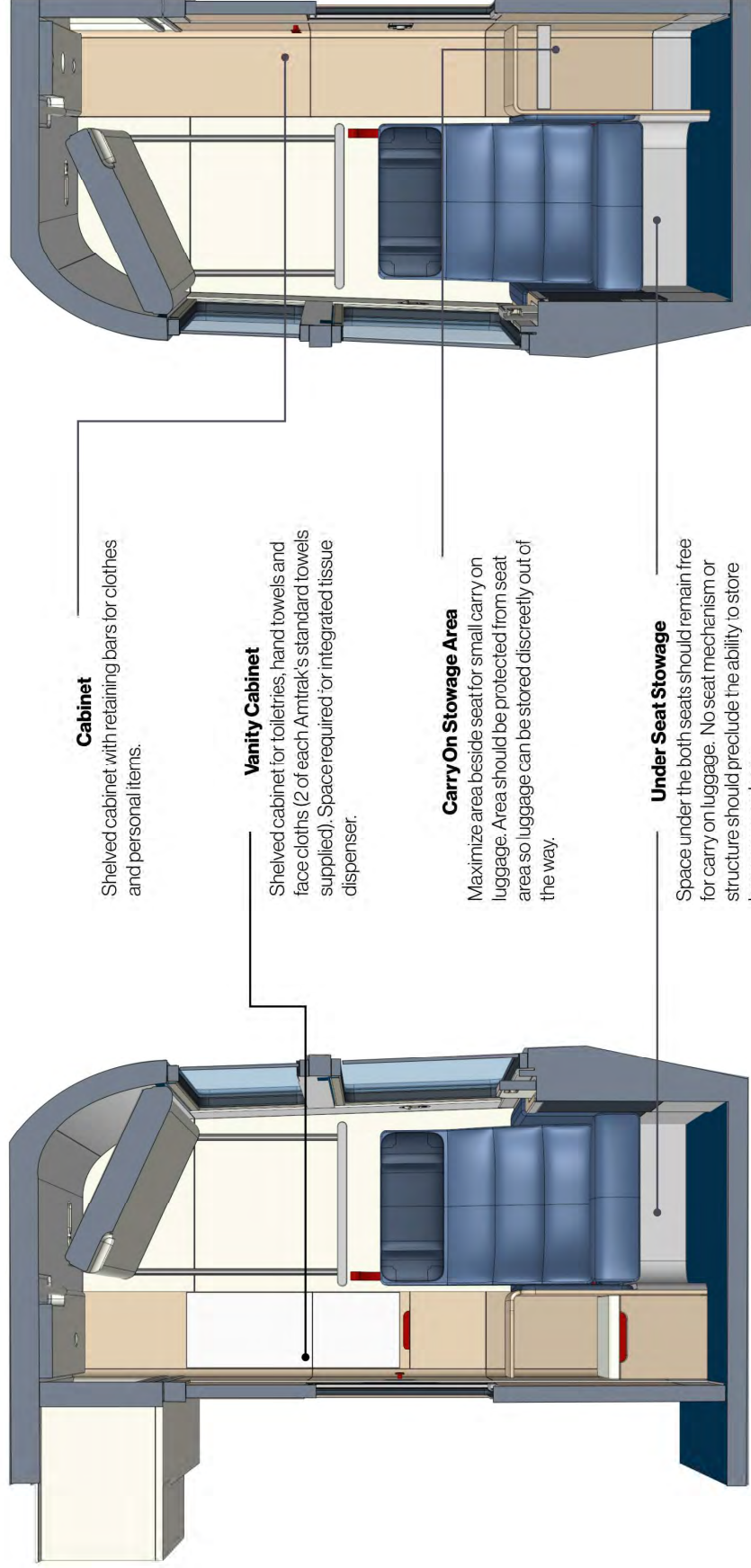

LH Side

RH Side

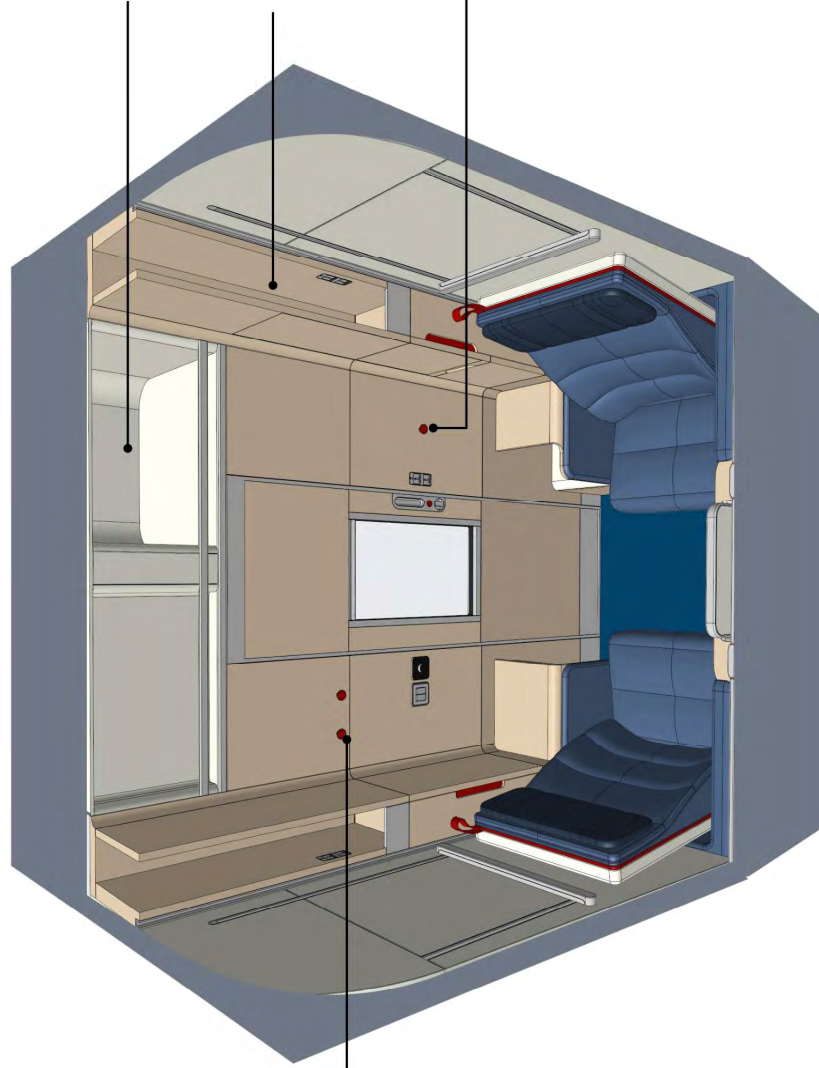

Upper Storage
High level storage for carry on luggage

Cubbies
Cubbies shall provide storage for personal items at both berth heights

Vanity Hook
Provision should be made to allow for wash bags or towels to be hung by the sink and vanity unit.

Hanging Space
At least two coat hooks should be provided on the inner wall, suitable to hang clothes or provide the function of an open wardrobe



25-FOI-0416 000004272 "UNCLASSIFIED" 4/2/2016

Roomette | Seat to Bed Conversions

Roomette | Seat to Bed Conversions

26-FD-10416 000000272 "UNC LAMINATED" 420762

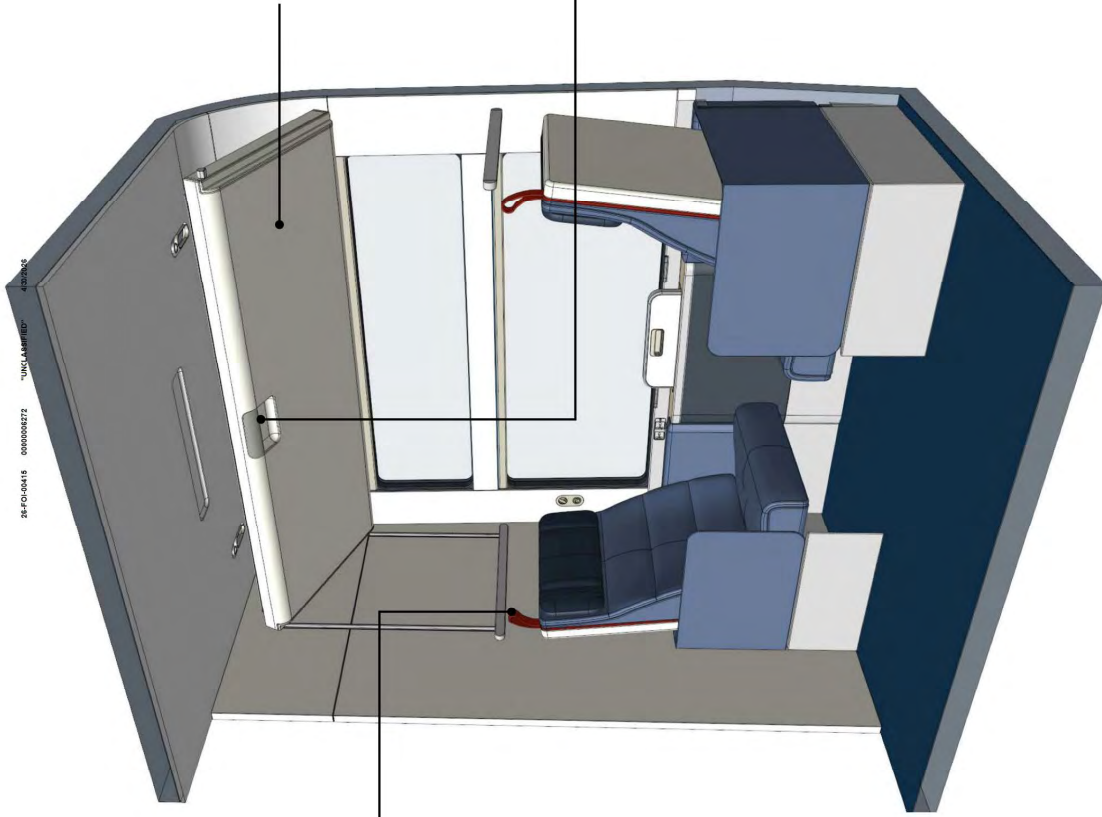

Lower Berth Deployment
A simple unlatch mechanism is required to convert the seats into a lower bed/berth. This should be positioned in a place that is easy for people to use and designed in a way so that people can understand its purpose.

Upper Bunk
Bunk should be stored horizontally at an optimized height in the room. Bunk should not preclude any part of the window when stowed.

Upper Bunk Deployment
A simple and easy to use handle, latch and lock mechanism should be within easy reach from a standing position. Successful locking should be visually indicated and safety measures should be put in place to prevent accidental deployment and prevent misuse.

Roomette | Seat to Bed Conversions

25-F-01-0416 000004272 "UNC (A) (M) (R) (D)" 4202021

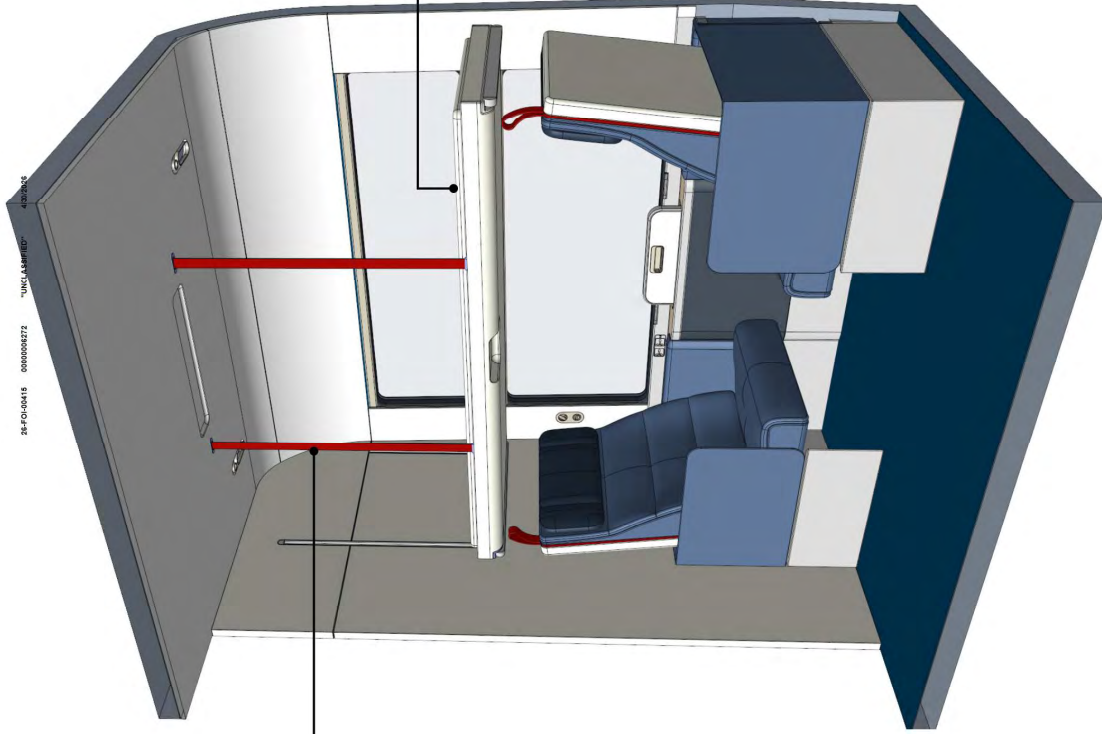

Bunk Retaining Straps

Retaining straps are required to prevent people from rolling out of the bunk. These should retract into the ceiling and be easily pulled down and click into place using an automatic locking retractor belt system (similar to a car seat belt system).

Bunk Height

The seated area below the bunk should still be usable by seated passengers when the upper bunk is deployed.

Roomette | Seat to Bed Conversions

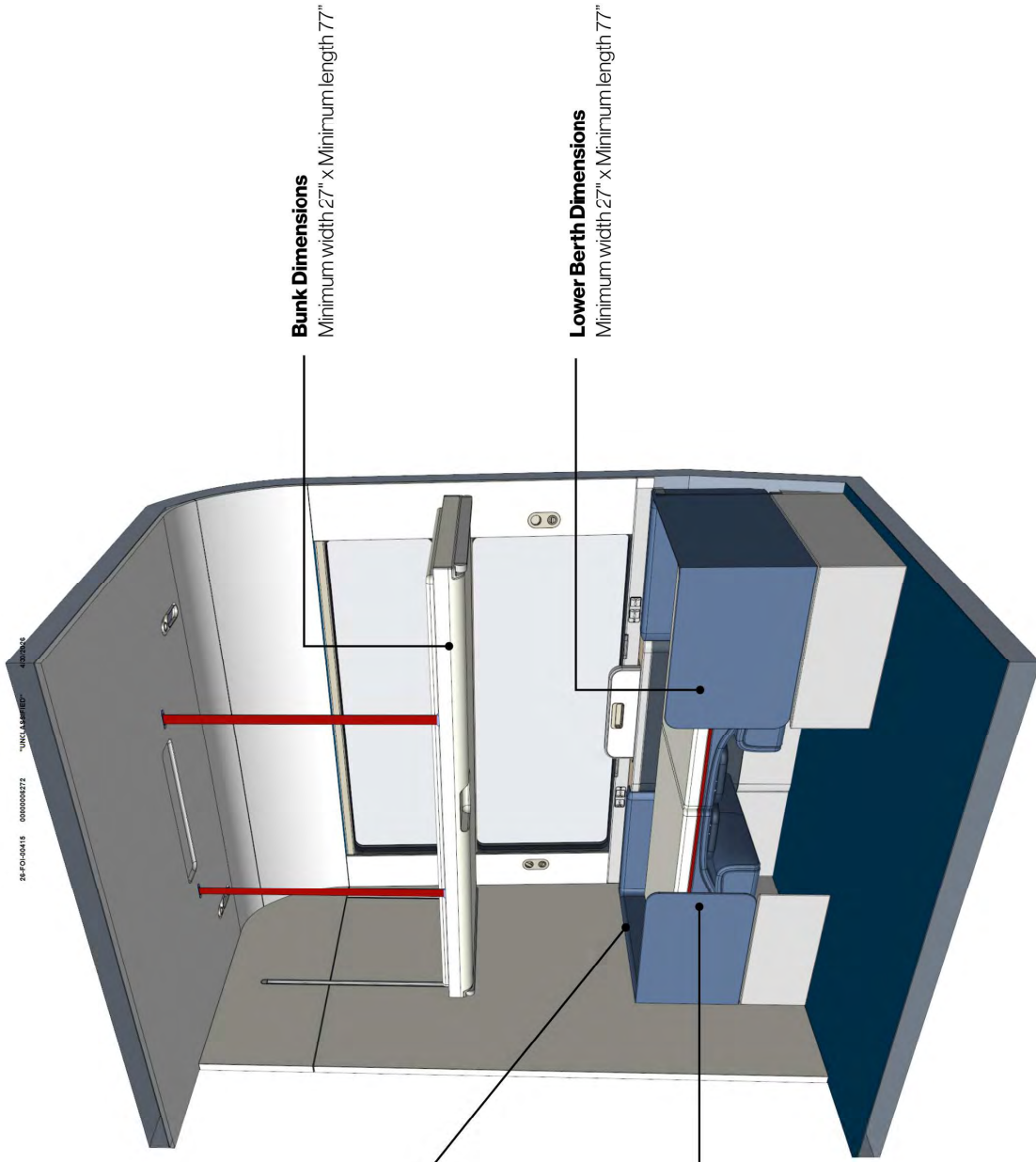

Head Board

The armrest and seat side pad should continue and connect to form a thin soft headboard around the back of the seat when the bed for the lower berth is down.

Lower Berth

Conversion of seats to bed should result in an entirely flat bed surface. The mattress surface should be integral to the seat. A single seam between the bed surface is acceptable with a single thin topper to finish the bed surface.



25-FOI-0415 000004272

"UNCLASSIFIED"

4/2/2014

Roomette | Lighting

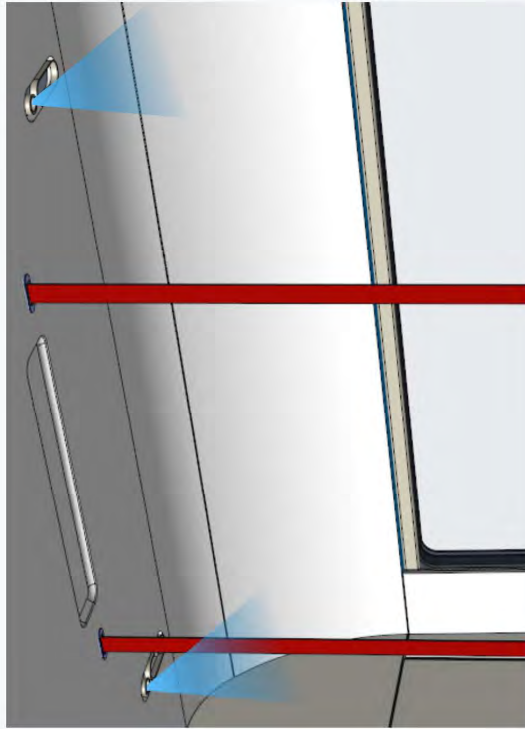

Upper Reading Lights

Reading lights should be provided embedded in ceiling above the bunk. These should be mini panel lights. 2 lights in total located at each end of the bed. Light switches should be located next to the reading light.



Lower Reading Lights

Reading lights should be provided at each seated location. People should be able to adjust the direction/ position of the light over their lap and in a suitable way to read a book at night. Switches should be located near or on the light.

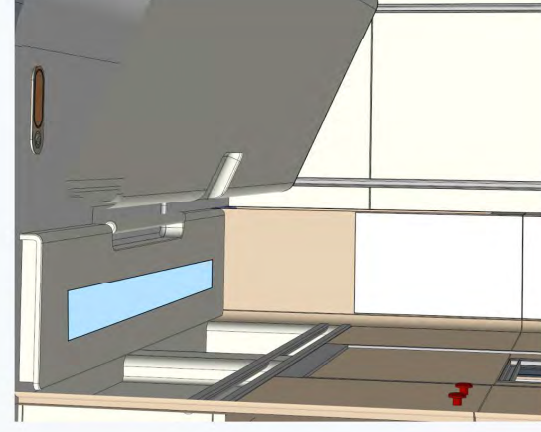

LED light panel light

LED light panels or panel spot lights provides ceiling master lights.

*See lighting spec for detailed definition

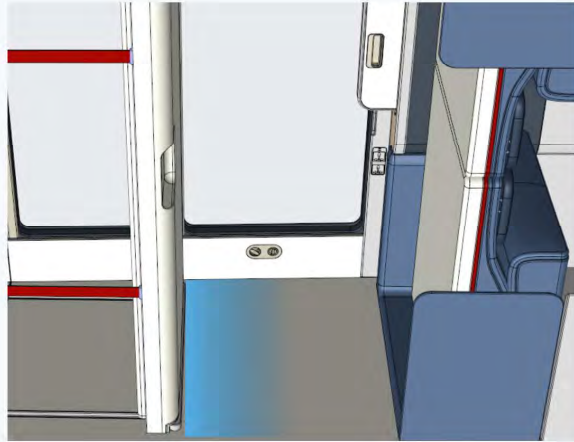

Back Wall Wash Light

Bunk support runner washes indirect light down the end walls on both sides of the room.

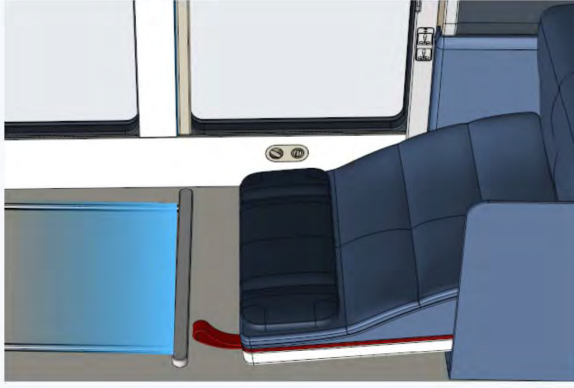

Back Wall Wash Light

Bunk support runner washes indirect light up across the end walls on both sides of the room.



Under Seat Light

Under seat light should be indirect and spill light out across the floor.



Step Light

Indirect light provides wash light over the steps.

*See lighting spec for detailed definition



26-FD-0416 00000272 "UNCLASSIFIED" 4/2024

- Coach Areas
- Sleeper Bedrooms**
- Food & Beverage
- Toilets & Showers
- Common Use Areas

Amtrak® Long Distance Product Features

05 | SoloSuite

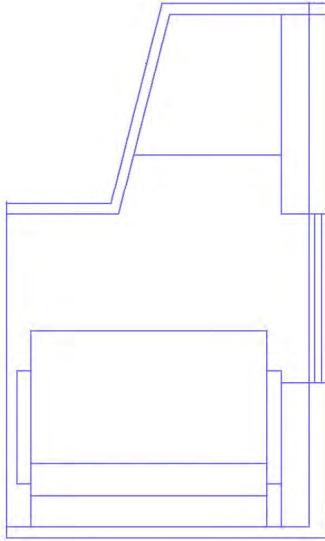

Solo Solo Suite

Solo Suite

Solo Suite is a room designed and optimized for a single occupant. Solo Suite rooms can be combined with a mirrored version of the room to create a larger twin room for two.

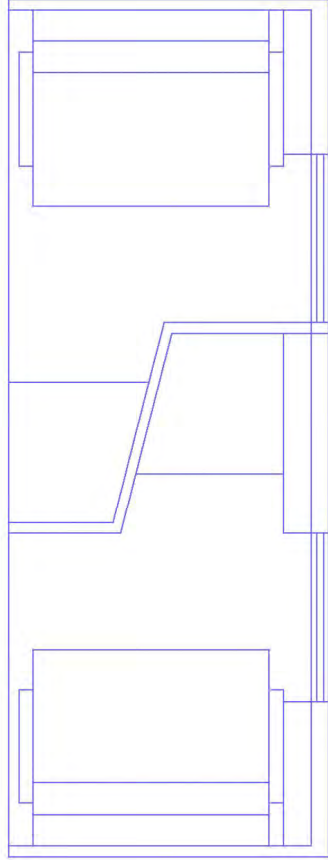

Twin Solo Suite

***The following diagrams illustrate two Solo Suite rooms as a facing pair.**

SoloSuite

SoloSuite rooms should be optimized for a central 24" aisle. Two SoloSuite modules combined (or facing pair) should be designed to a minimum length of 122".

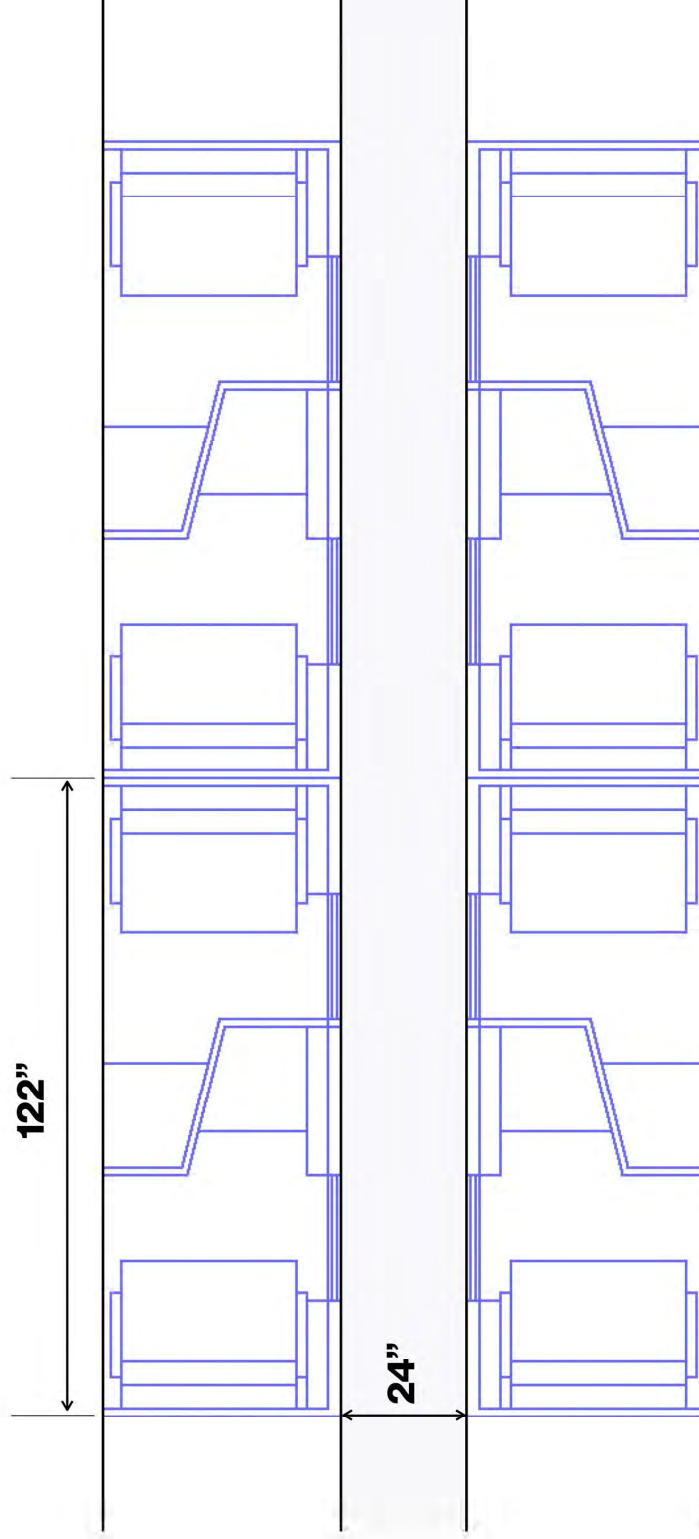



25-FOI-0415 000004272

"UNCLASSIFIED"

4/20/24

Solo Suite | Features

Solo Suite | Features

25-FD-10416 0000004272 "UNCLASSIFIED" 4/20/2016

Seat Headrests

Seat headrest should be adjustable in height for a range of people sizes and have adjustable wings that fold outwards to adjust the width of the headrest.

Seat Comfort

Seat cushions should be contoured to aid seat comfort.

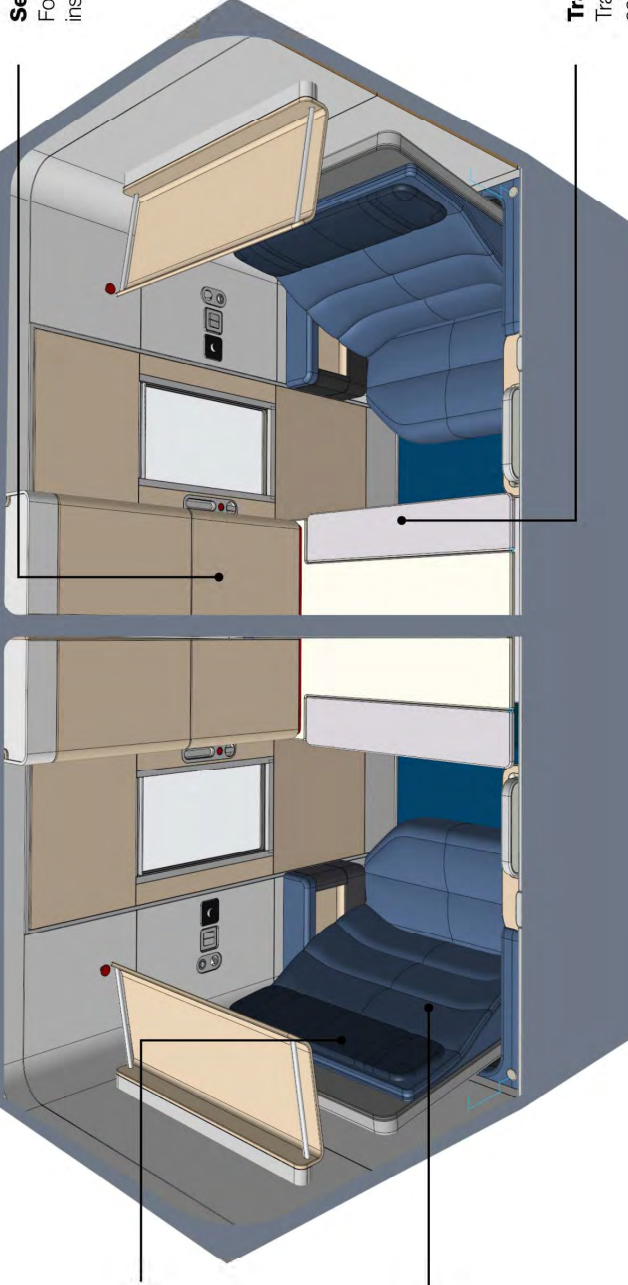

Seat Fold Out Sink

Fold out sinks shall be provided inside vanity cabinets

Trash

Trash bins shall be provided in each room located under central console.

Solo Suite | Features

25-FD-10416 0000004272 "UNCLASSIFIED" 4/20/2016

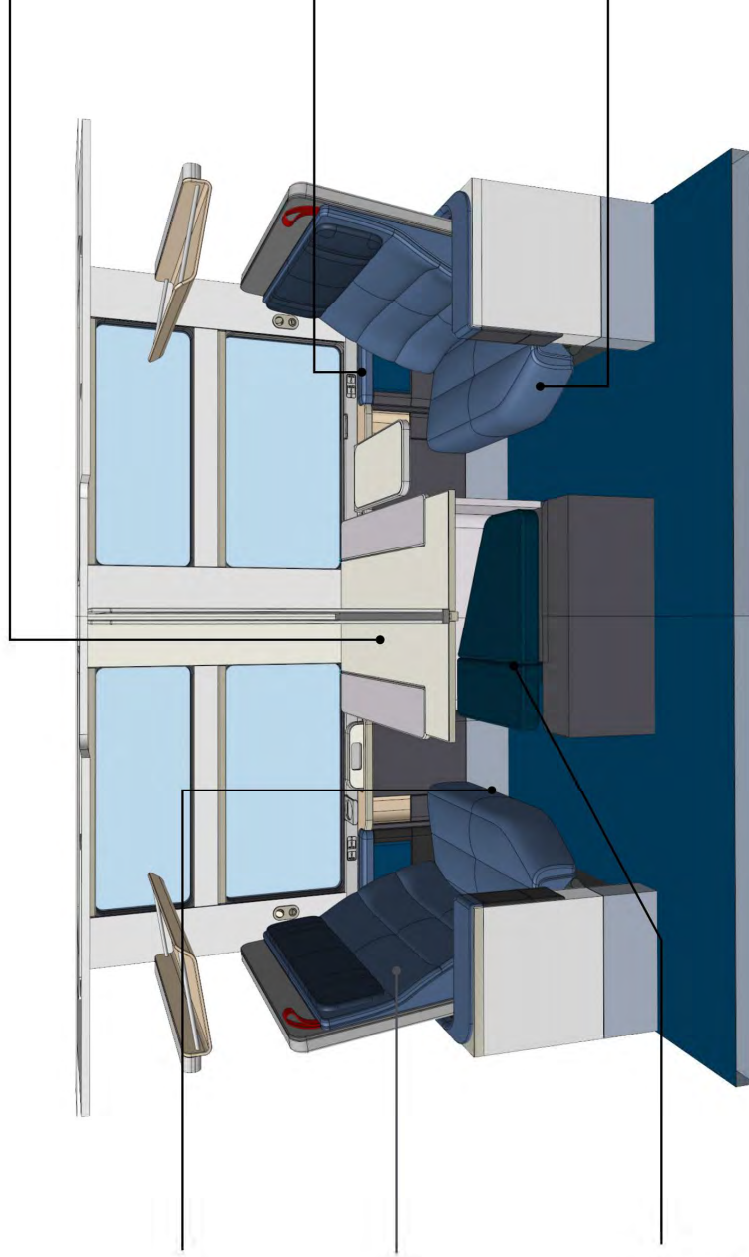

Seat Tracking

Seat should track forward so customers can utilize the large central table. The result will provide some recline for the seat.

Seat Dimensions

A minimum seat width between inside surfaces of armrests should be a minimum of 34". It should be possible to invite a companion into the room and comfortably sit side by side on the same seat.

Central Console

A fixed central console houses foot-boxes for the facing SoloSuite pairs. Careful balance between each pair should be considered to maximize living accommodation for each of the passengers.

Armrest

A full and cushioned armrest of 3.5" should be provided on both sides of the seat. The armrest should be of a suitable length for a seated passenger to rest their forearm on the cushioned section.

Seat pan shape

The seat pan should be profiled to maintain ingress and egress clearance. This is a high wearing area of the seat surfaces and this area should be suitably designed to be durable and free from snagging or entrapment.

Ottoman

A fixed ottoman should be provided inside a foot-box. A foldable portion of the ottoman should fold up to complete the bed surface and down to provide some standing space when the main part of the bed is deployed.

Solo Suite | Features

25-FD-10416 0000004272 "UNCLASSIFIED" 4/20/2016

Cup Holders

Each room should have one cup holder located so people can use and access the cupholders from a seated position. They should fold away when not in use.

Window and Window Mask

Window and window mask should be central to the room and overall window size maximized.

At Seat Power

Two power sockets and two USB sockets should be provided to each seated location. The position should be above the armrest height and in easy reach of people while seated.

Blinds

A single pull-down blind system shall be provided per window, capable of delivering both daytime solar/glare control and full blackout performance.

Fold out Table

Single leaf table deployed from side wall. The table height should provide good knee clearance for seated people with a height off the finished floor between 27" and 29". The table should be easy to deploy and stow with an intuitive handle.

Ottoman Table

The ottoman table should be large enough for face to face dining. When the seat is tacked forward, it should incorporate a folding leaf to create extra knee and turnover space for sleeping passengers. The leaf must not interfere with divider mechanism when folded.

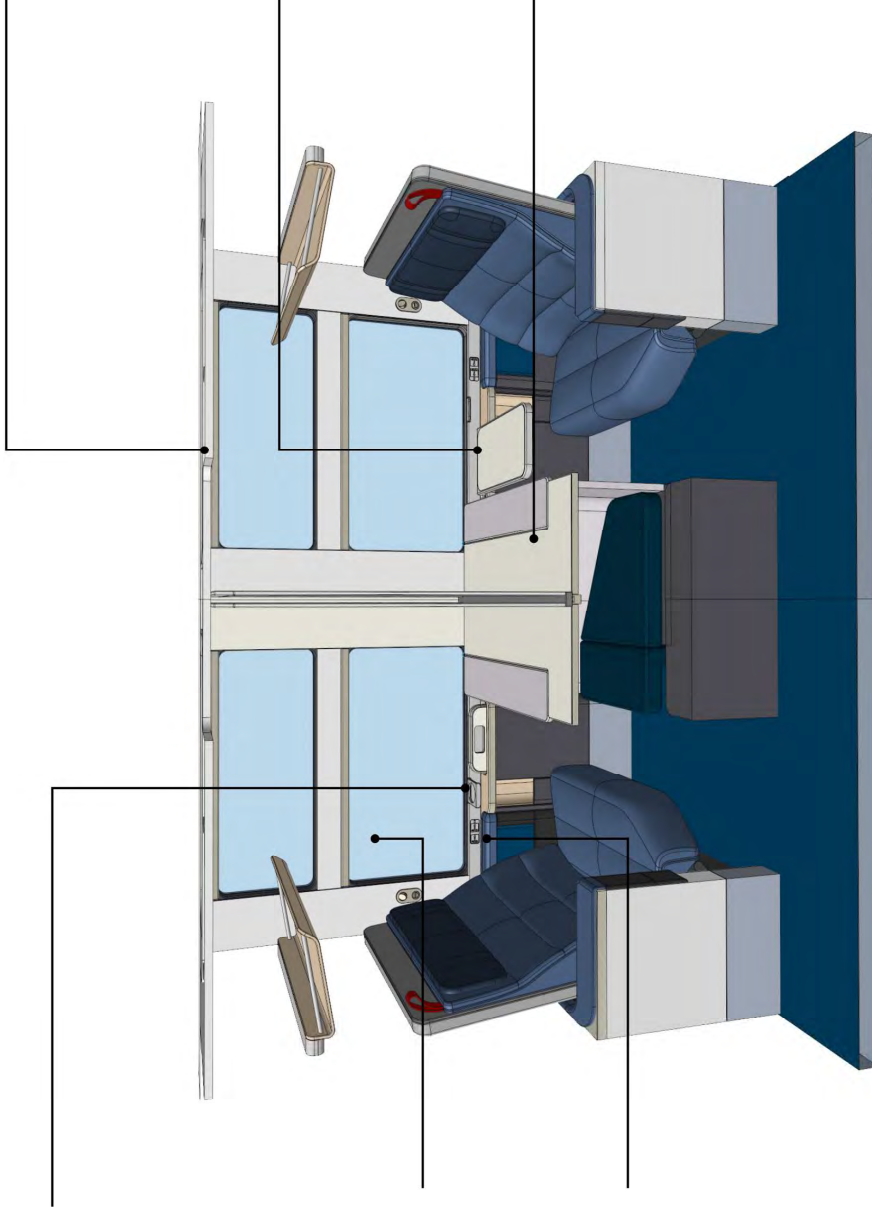

Solo Suite | Features

25-FD-10416 0000004272 "UNCLASSIFIED" 4/20/2016

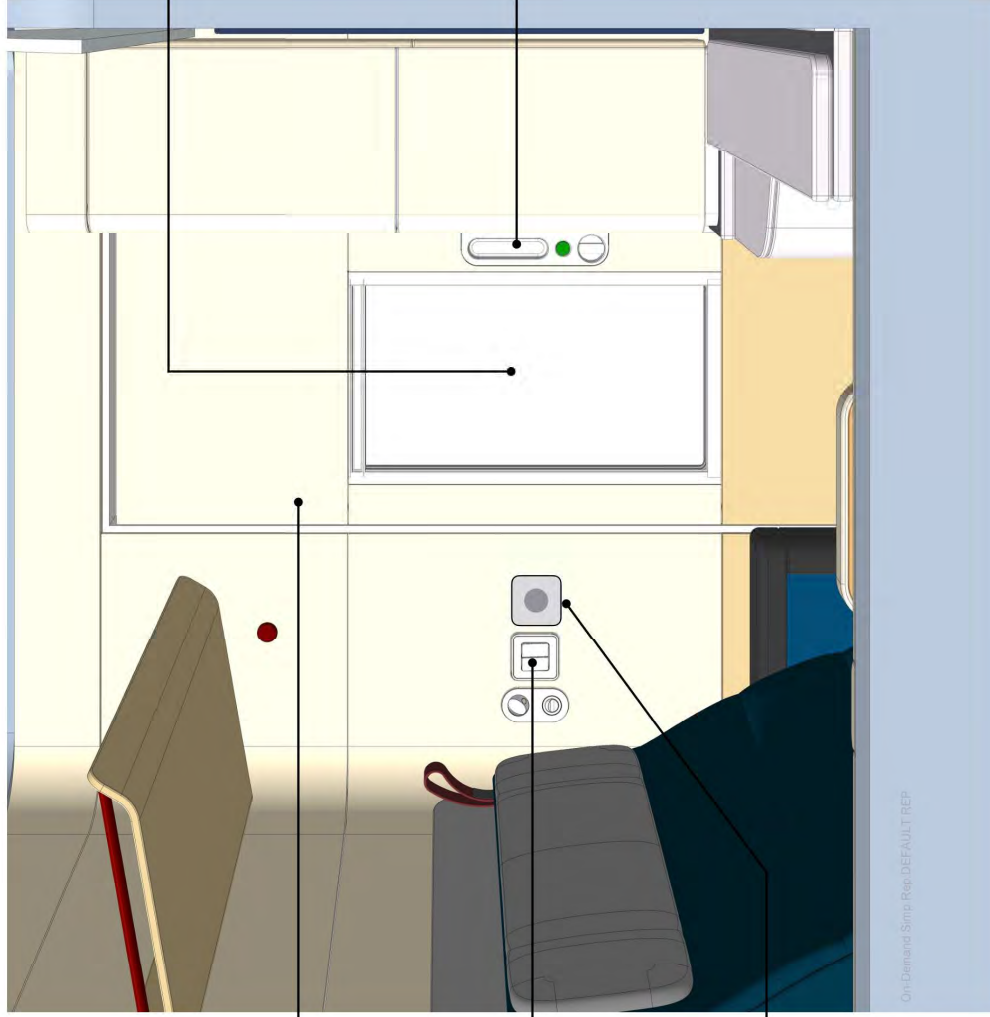

Door
Door free from rattle, smooth sliding operation.

Master Light Switch
Master light switches to be positioned near door. A second master switch should be safely accessible by a person lying in the top bunk.

Temperature Control

Door Window and Blind
Door window should be central to door and come equipped with an integrated blind.

Door Handle and Lock
Door handles should be positioned to slide door easily open and closed. An accessible manual lock should be included with an indicator to show lock condition.

On-Demand Smp. Rep. DEFAULT REP

Solo Suite | Features

Seat Dimensions

All seat dimensions, cushion density/ shore hardness will be subject to mockup review and approval by Amtrak

267-010416 0000008272

UNCLASSIFIED

420329

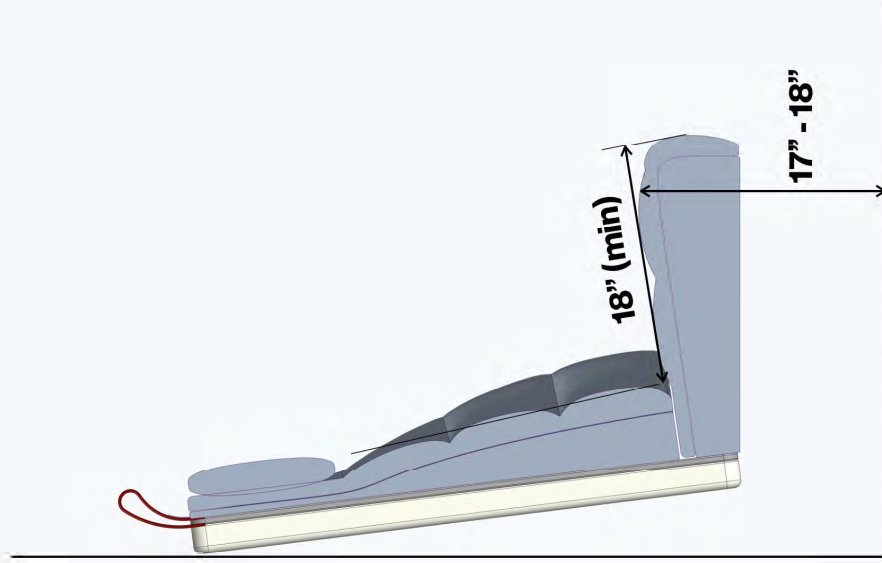

DRAWINGS NOT TO SCALE

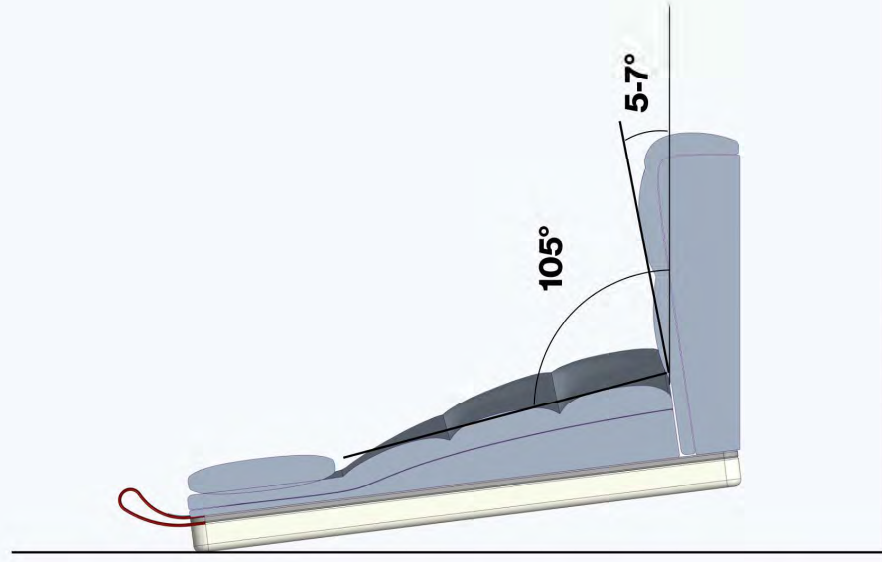

DRAWINGS NOT TO SCALE

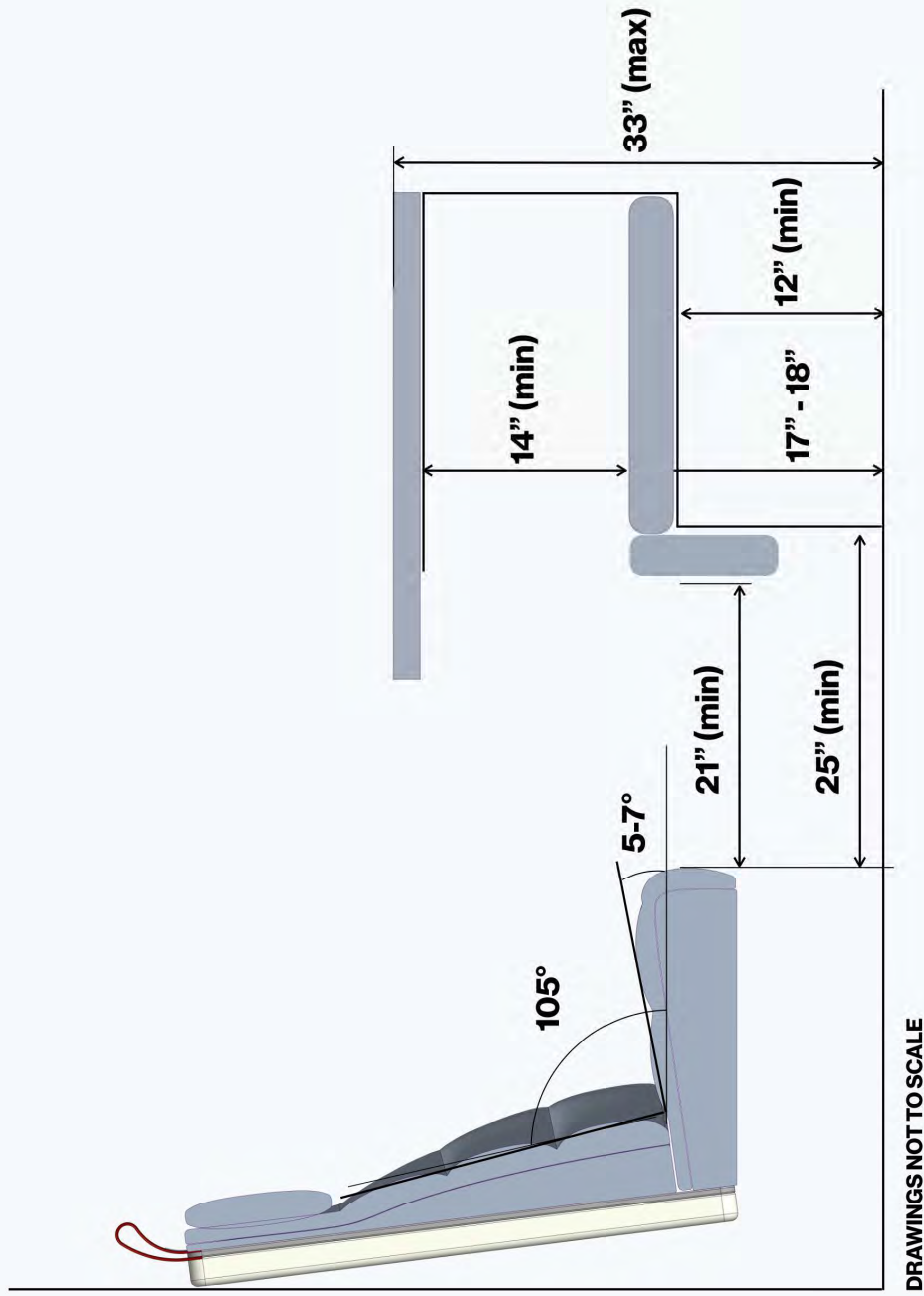

DRAWINGS NOT TO SCALE

Seat Tracking

Seat should track forward so customers can utilize the large central table and create some recline in the seat.

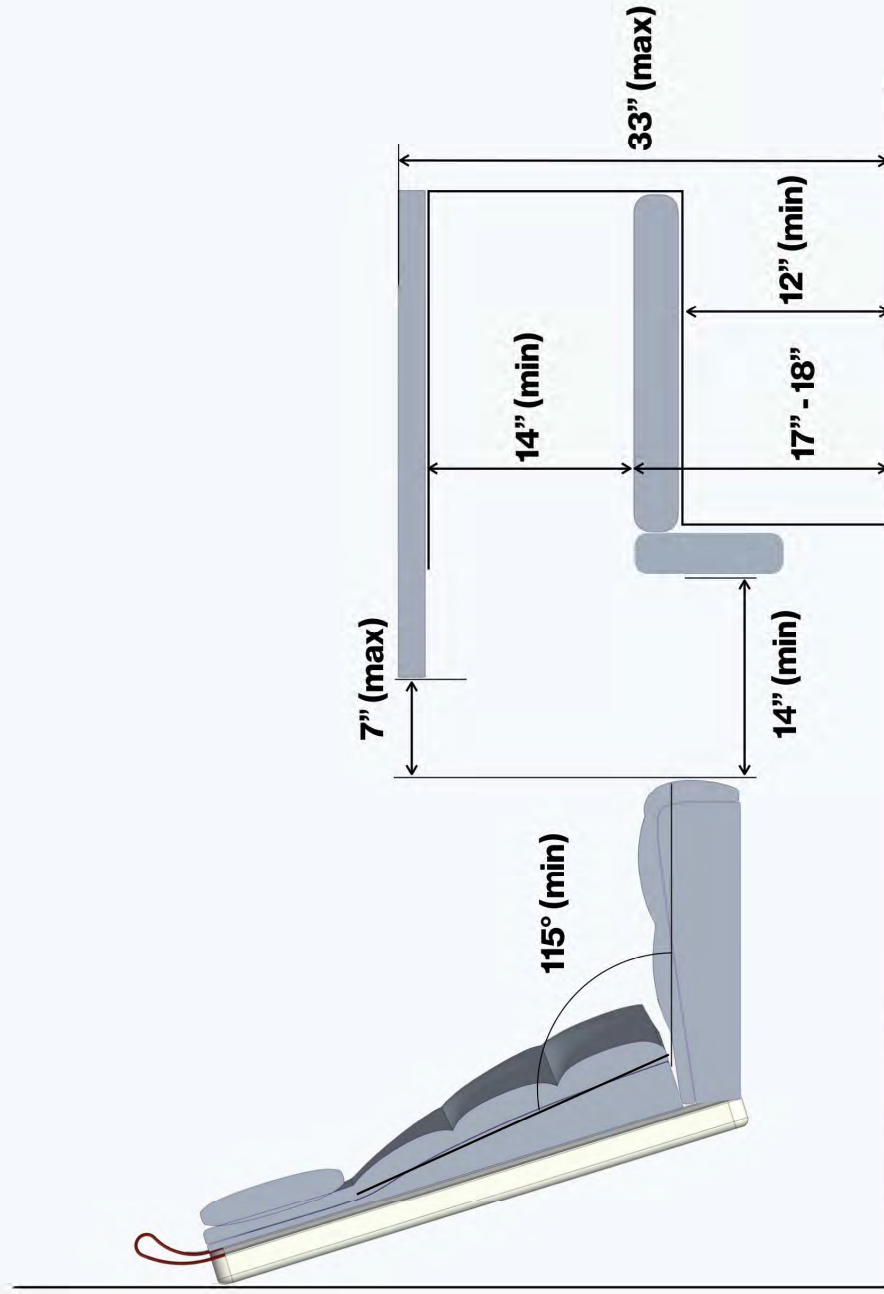

DRAWINGS NOT TO SCALE



25-F-0415 000004272

"UNCLASSIFIED"

4/20/24

Solo Suite | Storage

Solo Suite | Storage

26-FD-0416 000004272 UNCLASSIFIED 4/20/2016

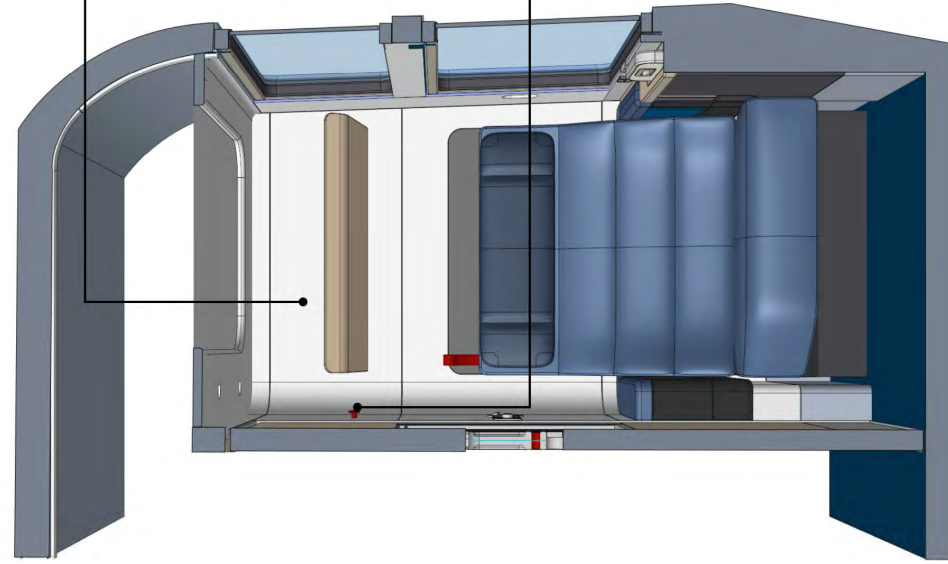

Seat Side

Luggage Rack

Luggage rack for clothes and/or small carry on luggage. The rack should be design to prevent luggage falling off in typical railroad conditions i.e. with lip or retention strap.

Vanity Cabinet

Shelved cabinet for toiletries, hand towels and face cloths and bath towel storage and integrated tissue dispenser. Mirror and towel shall be included

Hanging Space

At least one coat hook should be provided on the inner wall, suitable to hang clothes or provide the function of an open wardrobe.

Ottoman Storage

Space under the opposite passenger's ottoman should remain free for carry on luggage. The carry on luggage shouldn't encroach into the door space.

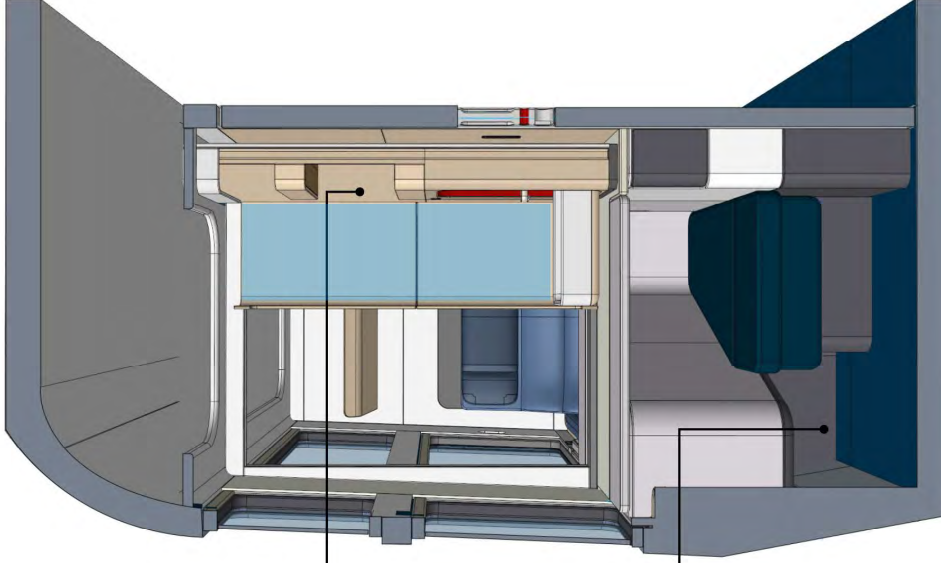

Ottoman Side

Solo Suite | Storage

2547010416 0000004272 "UNCLASSIFIED" 4/20/2016

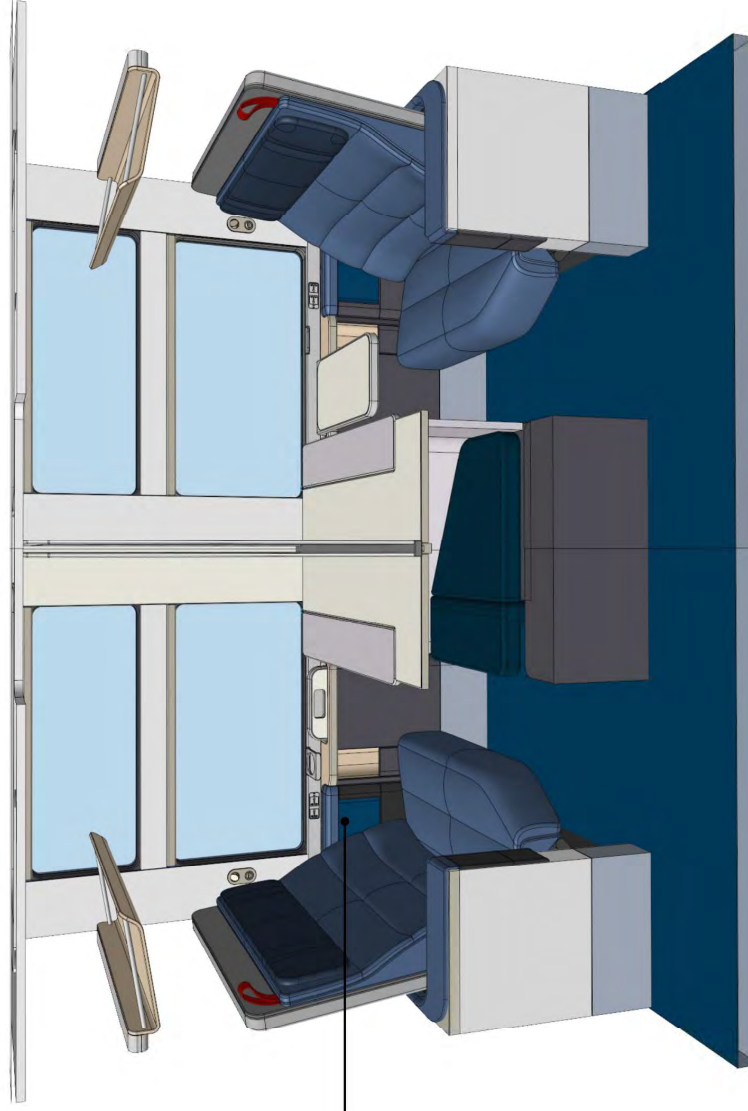

Armrest storage
Available space on each side of the seat shall be provide storage for personal items and water bottles.



25-F-01415 000004272

"UNCLASSIFIED"

4/2/2014

Solo Suite | Seat to Bed Conversions

Solo Suite | Seat to Bed Conversions

25-FD-0416 000004272 "UNCLASSIFIED" 4/20/2016



Ottoman Table
Table leaf fold up to create knee space.

Headboard
The armrest and seat side pad should continue and connect to form a thin soft headboard around the back of the seat when the bed for the lower berth is down.

Bed
Conversion of seat to bed should result in an entirely flat bed surface. The mattress surface should be integral to the seat. Seams between the bed surface and ottoman are acceptable if finished with a single thin topper. There should be no movement in the bed structure when fully loaded when the bed is deployed.

Folding Ottoman Pad
A folding ottoman pad should complete the seat surface between bed and ottoman. The pad should be independently operated. Care should be taken in the design and activation to avoid accidental entrapment or mitigate injury through misuse.

Bed Deployment

A simple unlatch mechanism is required to convert the seats into a lower bed/berth. This should be positioned in a place that is easy for people to use and designed in a way so that people can understand its purpose. The latch should be free from jamming and free from any finger trap hazards.

Standing space

The folding ottoman pad and ottoman table leaf should create a space large enough for passenger to stand and deploy and stow the bed while in the room with the door closed.

Solo Suite | Seat to Bed Conversions

2547010416 0000004272 "UNCLASSIFIED" 4/20/2024

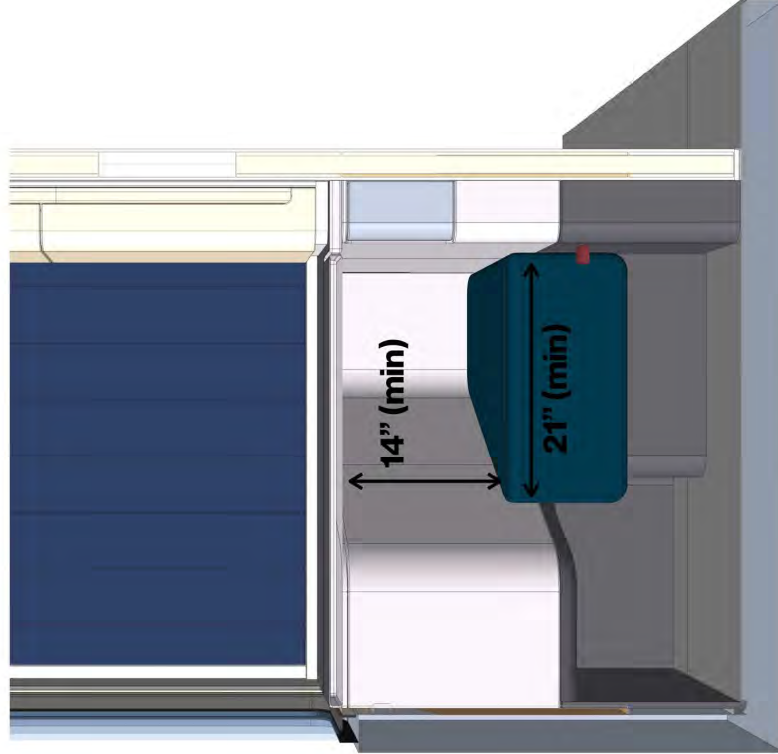

Foot-box threshold

There should be a minimum of 14" between the top of the ottoman/bed surface and the underside of the foot-box/table surface. There should be a minimum of 22" between the two sidewalls at the threshold of the foot-box.

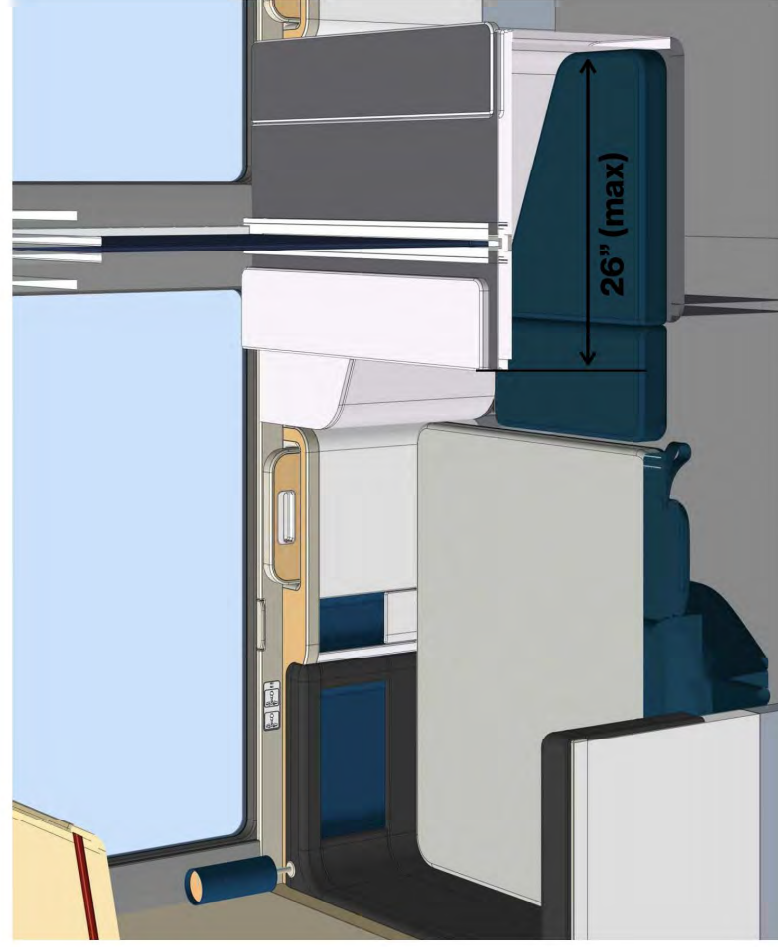

Foot-box depth

The foot-box should be a maximum of 24" deep when the ottoman pad table is folded up.

Solo Suite | Seat to Bed Conversions

254-FO-0416 000004272 "UNCLASSIFIED" 4/20/2016

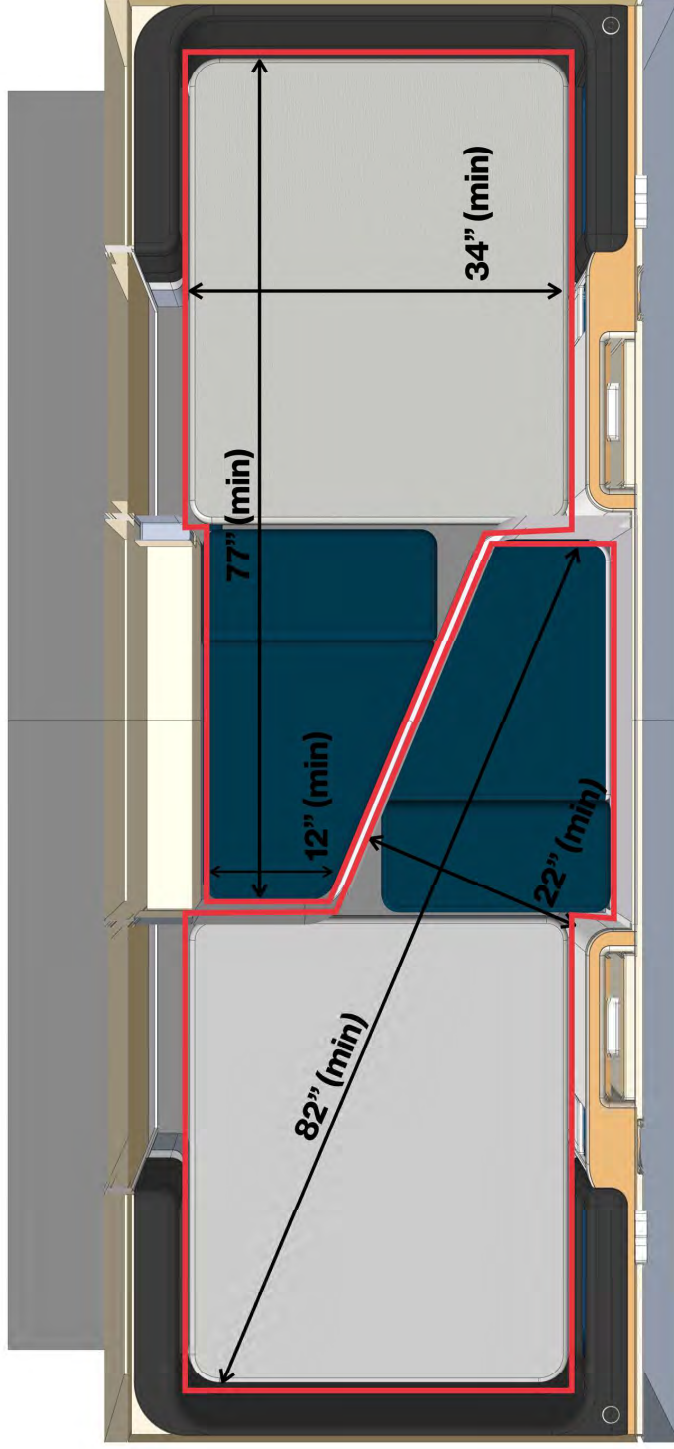

Bed dimensions

There should be a minimum of 82" between the two opposite corners to account for the tapering bed shape.
There should be a minimum of 22" between the inside surface of the foot-box and any sidewall structure.
Dimensions and usability will be subject to Amtrak approval.

Bed dimensions cont.

There should be a minimum of 77" bed length.
There should be a minimum of 34" bed width.
Dimensions and usability will be subject to Amtrak approval.



25-F-01416 000004272 "UNCLASSIFIED" 4/20/24

Solo Suite | Connecting Rooms

Solo Suite | Connecting Rooms

26-FOI-00416 0000004272 "UNCLASSIFIED" 4/20/2016

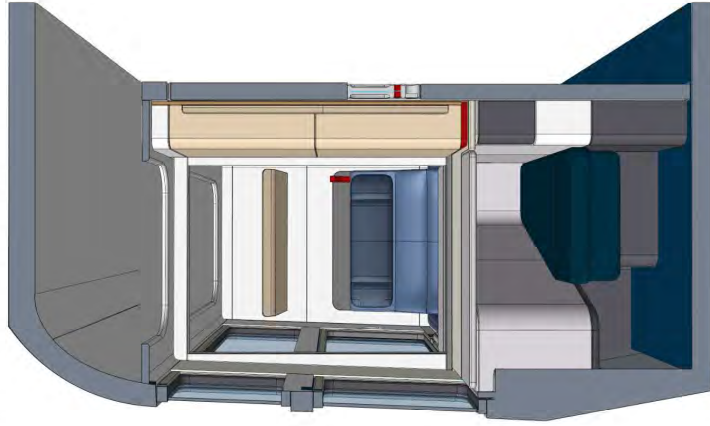

Open (Stowed)

The divider must stow away neatly into a pocket, wall or ceiling and not protrude into the room. When stowed the divider must be free from rattle and movement and be securely retained in its stowed position. The opening should be maximized and be a minimum of 35" x 35". The stowed divider must not prevent the use of any other of the room's features or obscure the window or skylight.

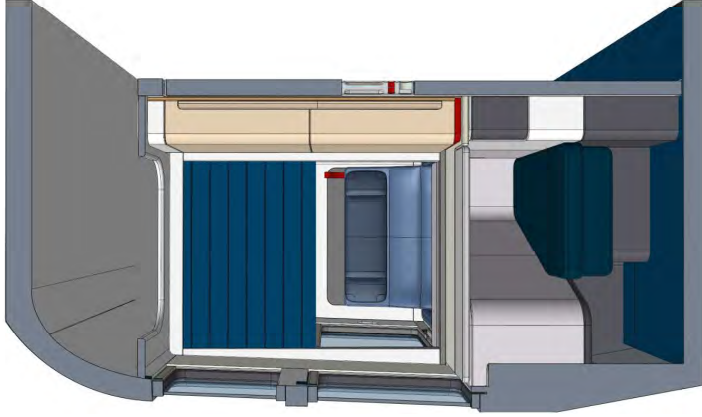

Deployed

As the divider is deployed it must be done with a smooth and gliding motion, with little or no noise. The deployment of the divider should be easy to use and be able to be operated safely by passengers independently.

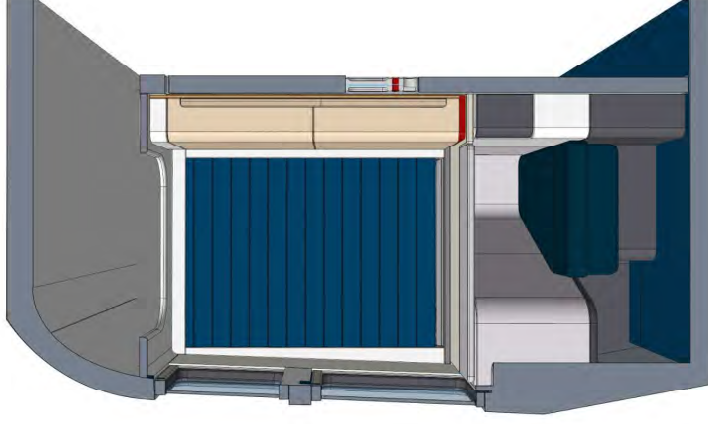

Closed

When divider is in its closed position it must provide good sound insulation to the adjoining room, no less than that of a normal module wall. The divider must be securely locked in place with a visual indicator on both sides of the room to show that it is locked. A solution must be found to prevent one passenger opening the divider without the other's permission, such as a double latch.

When closed the divider must be free from rattle and movement and be securely locked in place along all edges. There should be no light spill from the adjoining room.



25-FOI-0416 000004272

"UNCLASSIFIED"

4/20/24

Solo Suite | Lighting

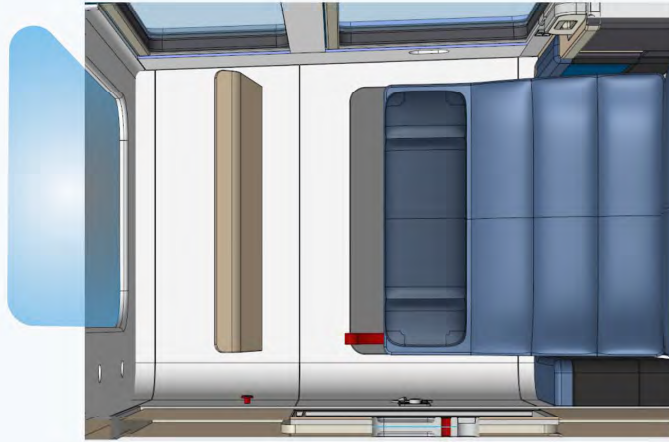

Master Ceiling Light

Central light well acts as master ceiling light.

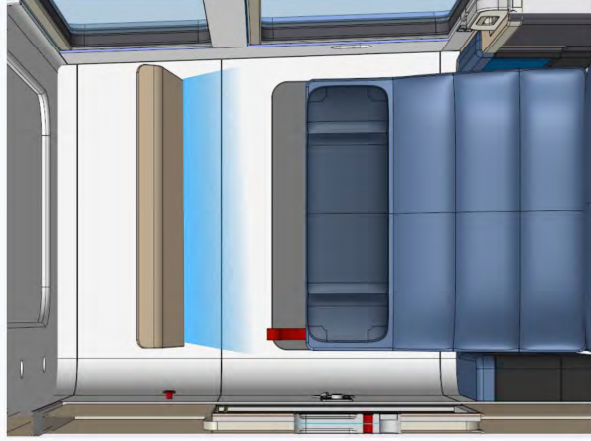

Rack Wash Lights

Indirect wash light running across the width of the room behind the luggage rack

*See lighting spec for detailed definition



Lower Reading Lights

Reading lights should be provided at the seated location. People should be able to adjust the direction and position the light over their lap and in a suitable way to read a book at night. Switches should be located near or on the light.



Under Ottoman Light

Indirect light provides additional light well inside luggage stowage area.



Foot-box light

Indirect light provides additional light well inside the foot-box.

*See lighting spec for detailed definition



26-FD-0416 00000272 "UNCLASSIFIED" 4/2024

- Coach Areas
- Sleeper Bedrooms**
- Food & Beverage
- Toilets & Showers
- Common Use Areas
- Crew Areas

Amtrak® Long Distance Product Features

06 | Club Bedroom

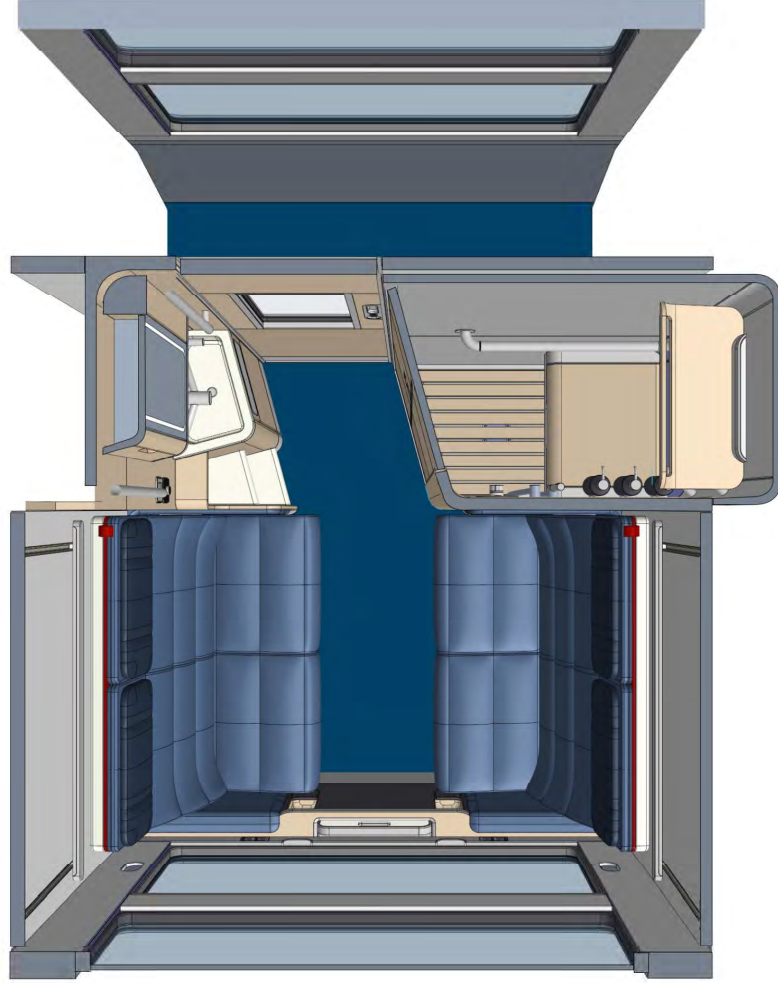

The Club Bedroom

The Club Bedroom should be designed to be a great bedroom for two but also suitable for four people to sit and sleep together. The room should work alongside a 32" accessible aisle. The room comes equipped with a vanity sink and an ensuite toilet and shower.

81"

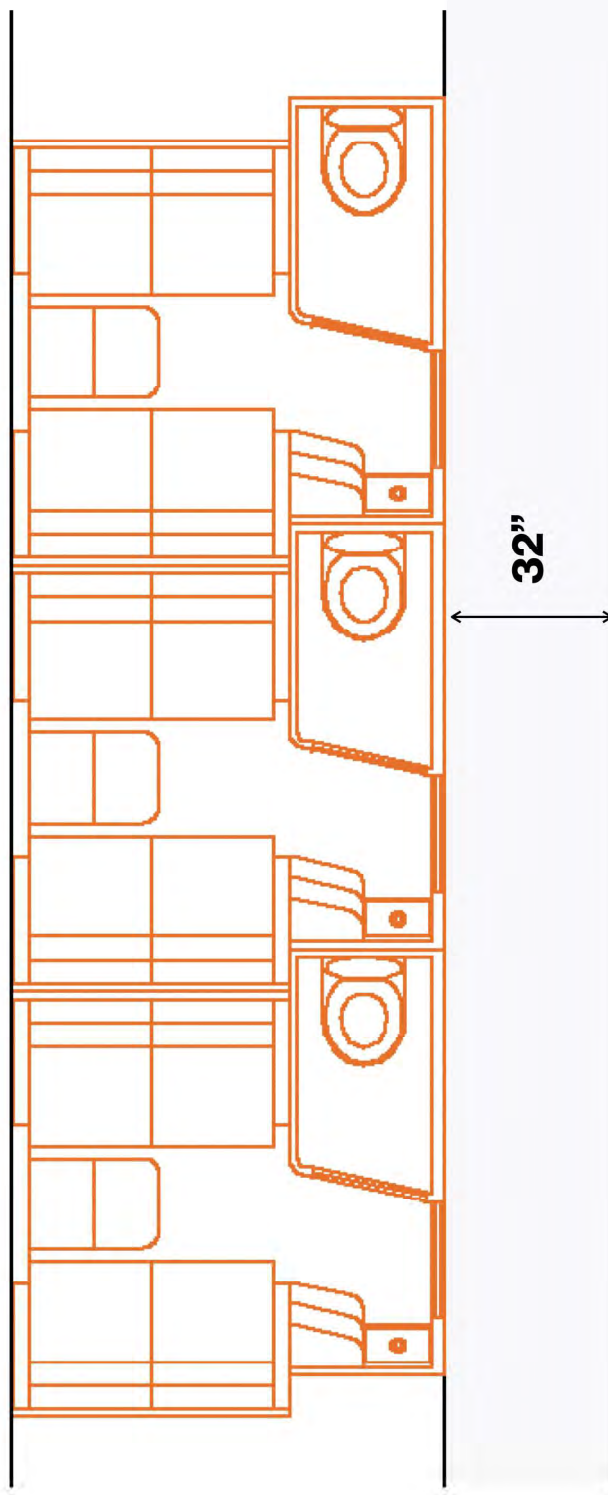
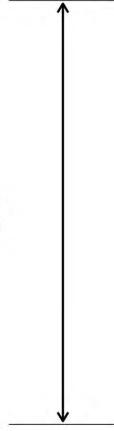

32"

Modules

Modules are 81" in length. Rooms are pitched at 81". The toilets are offset allowing central access to the bedroom.

Aisle Requirements

Works in combination with a 32" accessible aisle



RP-01416 000004272 UNCLASSIFIED 4/2/2016

Club Bedroom | Features

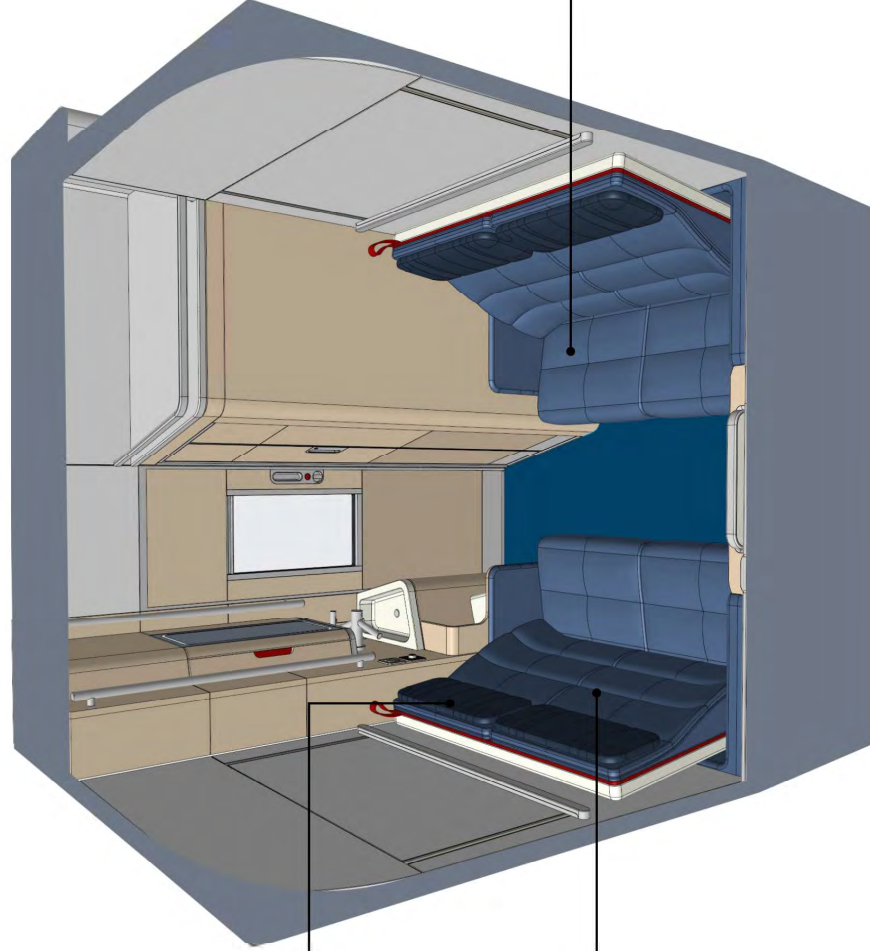

Seat Headrests
Seat headrests should be adjustable in height for a range of people sizes. There should be four headrests in total. They should have adjustable wings that fold outwards to adjust the width of the headrest.

Seat Comfort
Seat cushions should be contoured to aid seat comfort.

Seats
The Club Bedroom should have four comfortable seats which should also act as two wide couches so people can spread out.

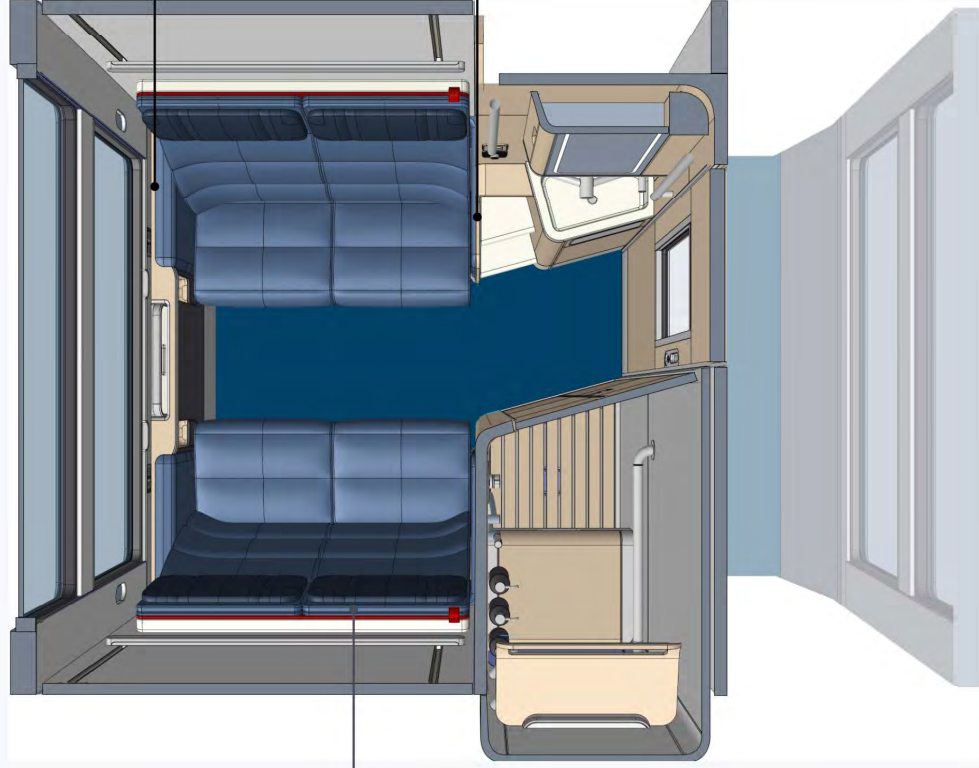

Seat Dimensions

A minimum seat width between inside surfaces of armrests should be a minimum of 48".

Armrest

A full and cushioned armrest of 3.5" should be provided on the window side.

Seat side pad

A soft seat side pad is required on the inside side of the seat to balance the look of the seat and allow some cushioning to the inside edge of the seat and to soften the joining panel work.

Seat Dimensions
All seat dimensions, cushion density/ shore hardness will be subject to mockup review and approval by Amtrak

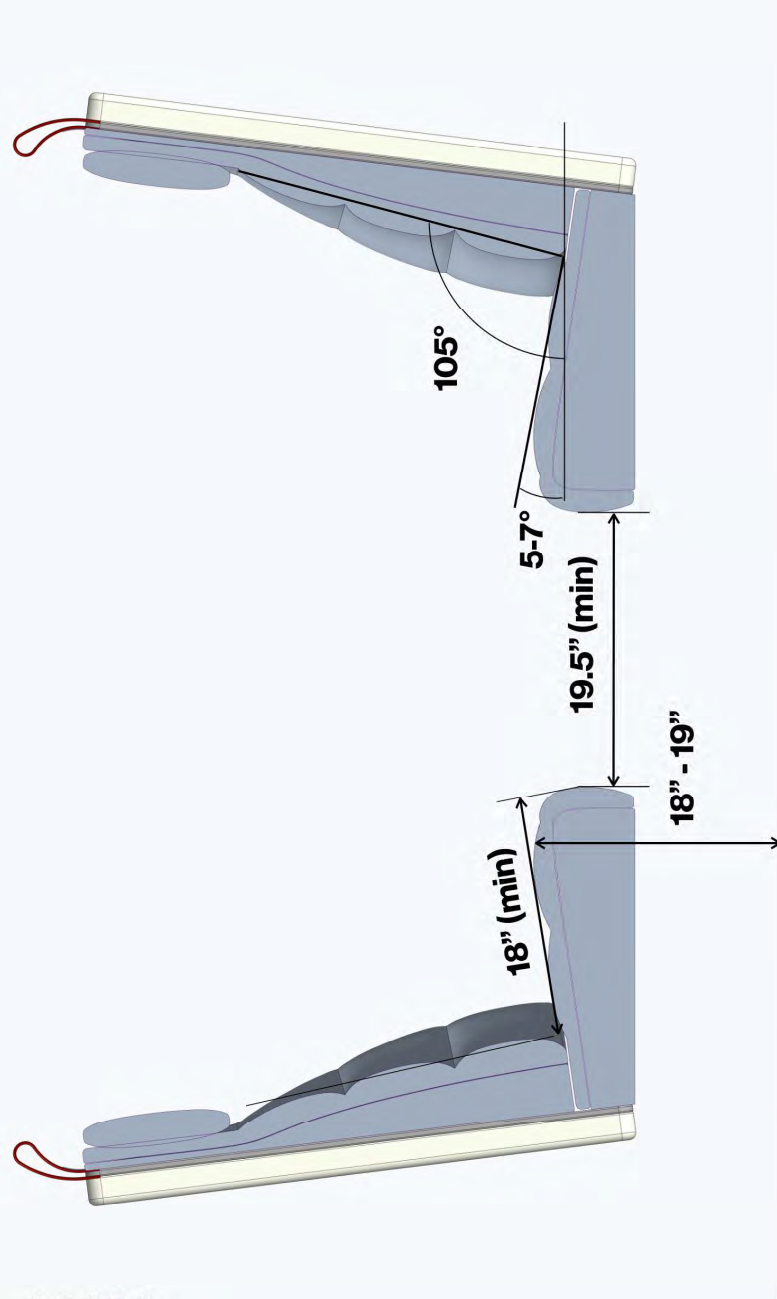

Club Bedroom | Features

25-FD-0416 000004272 "UNCLASSIFIED" 4/20/2016

81

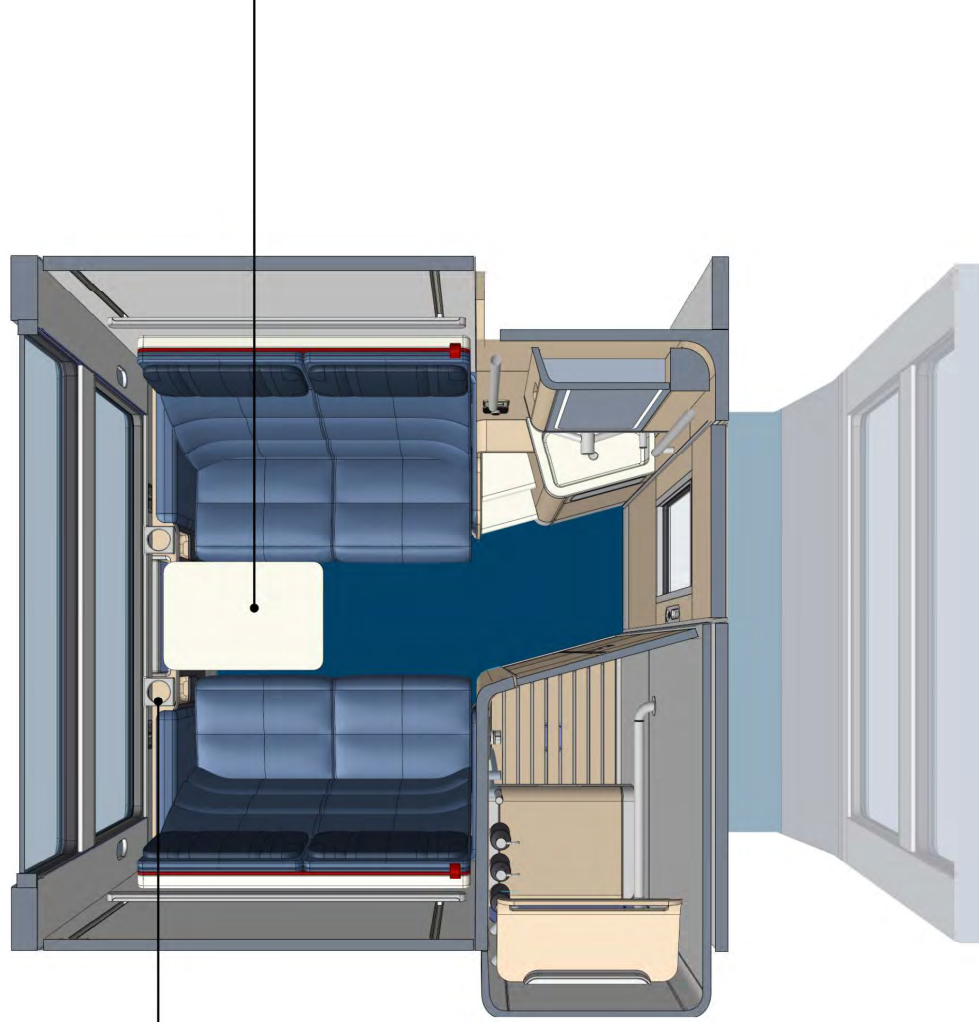

Cup Holders
One for each side for the room located so people can use and access; the cupholders from a seated position by the window. They should fold away when not in use.

Fold out Table

A single leaf table deployed from side wall should be supplied. The table height should provide good knee clearance for seated people with a height off the finished floor between 27" and 29". The table should be easy to deploy and stow with an intuitive handle.



Blinds

A single pull-down blind system shall be provided per window, capable of delivering both daytime solar/glare control and full blackout performance.

Window and Window Mask

Window and window mask should be central to the room and overall window size maximized.

At Seat Power

Two power sockets and Two USB sockets should be provided at each seated location by the window.

Cubbies

Cubbies shall be built into available space for stowage of personal items.

Club Bedroom | Features

26-PO-04116 0000004272 "UNCLASSIFIED" 4/20/2016

83

Power Outlets

Two power sockets and two USB sockets shall be positioned the by the vanity area.

Master Light Switch

Master light switches to be positioned near door. A second master switch sets a preset condition in the toilet/shower room. A second bank of master switches should be safely accessible by a person in the top bunk.

Temperature Control

Trash

A trash bin should be provided below the sink. Access to the bin should be provided via a swing door. The bin should be watertight in case of a spill to prevent any water escapement.

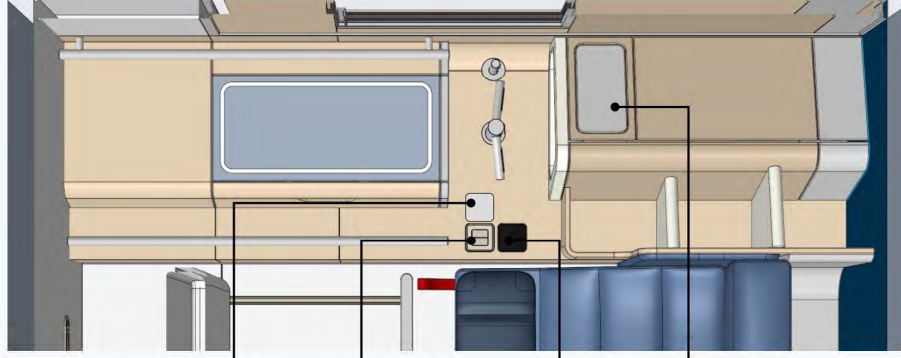

RH Side



LH Side

Power Outlets

Two power sockets and two USB positioned by the open wardrobe within easy access of seated passengers.

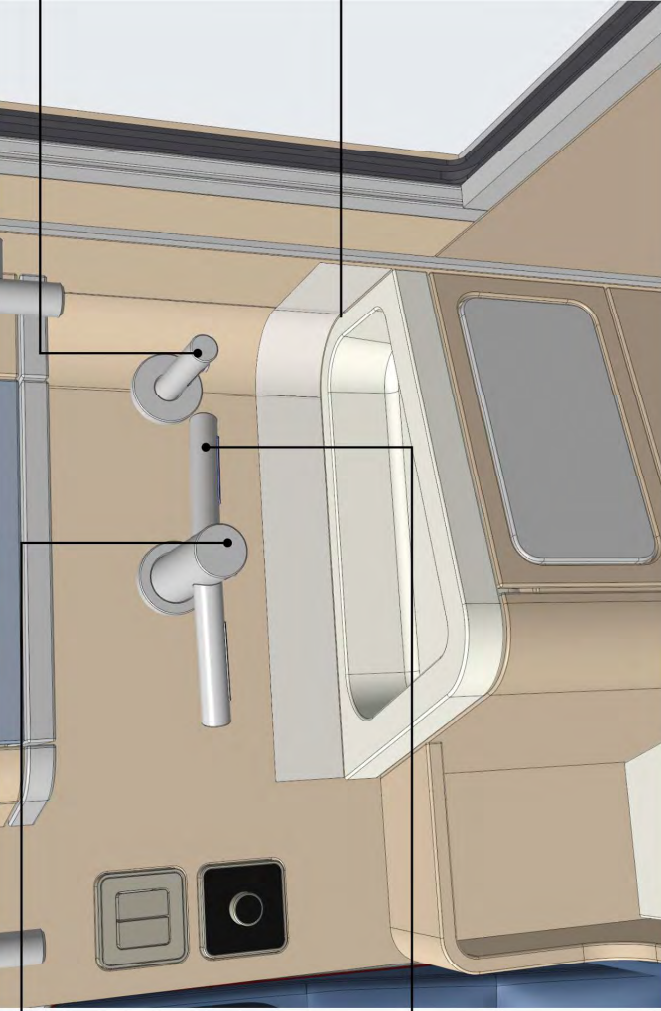

Automatic Water Faucet
Water is automatically dispensed when hands are placed under the faucet. A physical element should be visible so it is clear where water is dispensed from. Water pressure, water flow should not create any water splash or spill outside of the sink area.

Automatic Hand Drier
An automatically triggered hand dryer should be included under the vanity unit. This can be part of the faucet or supplied separately. A physical element should be visible so it is clear how to use the dryer. The dryer should use high velocity air and HEPA filters similar to a Dyson Airblade. The air dryer should not blow water out of the sink.

Soap Dispenser

An automatic soap dispenser should be included above the sink area. A physical element should be present to indicate how and where the soap will dispense.

Sink

The sink should have a marine edge so any water spills captured in the sink area. A splash back behind the sink should protect the surrounding areas from water splashed onto the back wall from the sink area. An area on the side of the sink should be reserved for a refillable hand lotion bottle fixed to the side wall.



Door Window and Blind

Door window should be central to door and come equipped with an integrated black out blind.

Door Handle and Lock

Door handles should be positioned to slide door easily open and closed. An accessible manual lock should be included with an indicator to show lock condition.

Door

Door free from rattle, smooth sliding operation.



25-F-01415 000004272 UNCLASSIFIED 4/2/2018

Club Bedroom | Storage



Vanity Cabinet

Shelved cabinet for toiletries, hand towels and face cloths (4 of each Amtrak's standard towels supplied). Space required for integrated tissue dispenser. Internal light activated as cabinet is opened. Mirror fronted.

RH Side

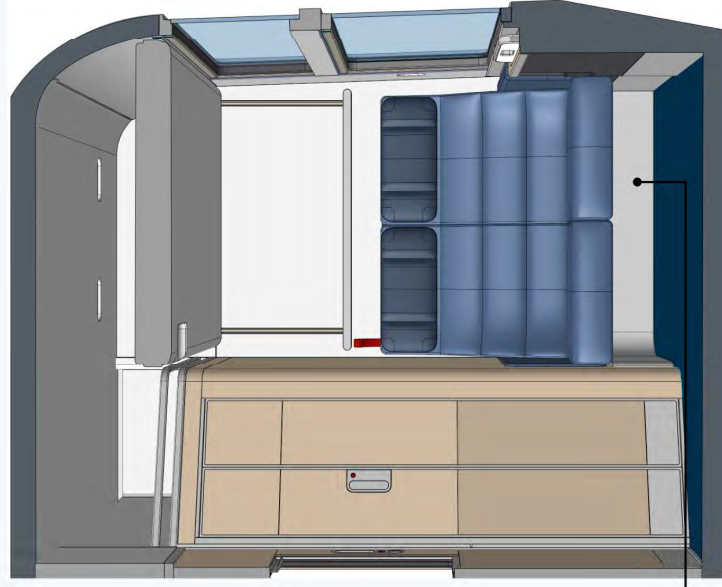

Under Seat Storage

Space under the both seats should remain free for up to four pieces of carry on luggage. No seat mechanism or structure should preclude the ability to store large carry on bags.

LH Side

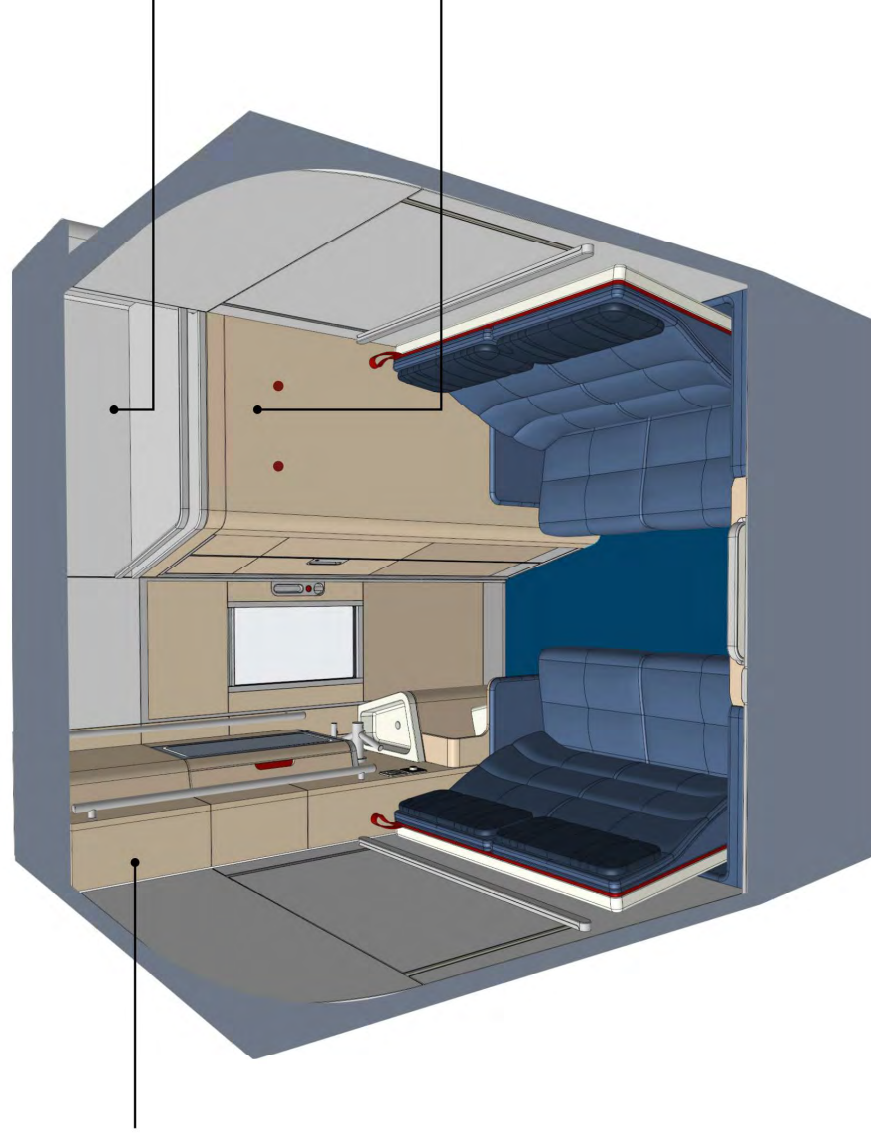

Upper Cubbies
Cubbies shall be provide storage for personal items where possible at upper bunk level.

Upper Storage
Upper storage shall be provided for carry on cases above the aisle or bathroom.

Open Wardrobe
At least two coat hooks should be provided within an open wardrobe. The space should be large enough to hang clothes on coat hangers.



25-F010416 000004272 UNCLASSIFIED 4/20/24

Club Bedroom | Seat to Bed Conversions

Club Bedroom | Seat to Bed Conversions

24-FD-0416 000004272 "UNCLASSIFIED" 4/20/2016



Lower Berth Deployment

A simple unlatch mechanism is required to convert the seats into a lower bed/berth. This should be positioned in a place that is easy for people to use and designed in a way so that people can understand its purpose.

Upper Bunk

Bunk should be stored horizontally in the room. Bunk should not preclude any part of the window when stowed. The bunk's stored height should be optimized in both seated and standing positions.

Upper Bunk Deployment

A simple and easy to use handle, latch and lock mechanism should be within easy reach from a standing position. Successful locking should be visually indicated and safety measures should be put in place to prevent accidental deployment and prevent misuse.

The bunk deployment should be free from jamming and racking and should lower slowly and in a controlled manner. Considerations should be made for assisted movement or counter balances to assist people moving the bunk down and back up into the stowed position.

Club Bedroom | Seat to Bed Conversions

24-FD-0416 000000272 "UNCLASSIFIED" 4/20/2016

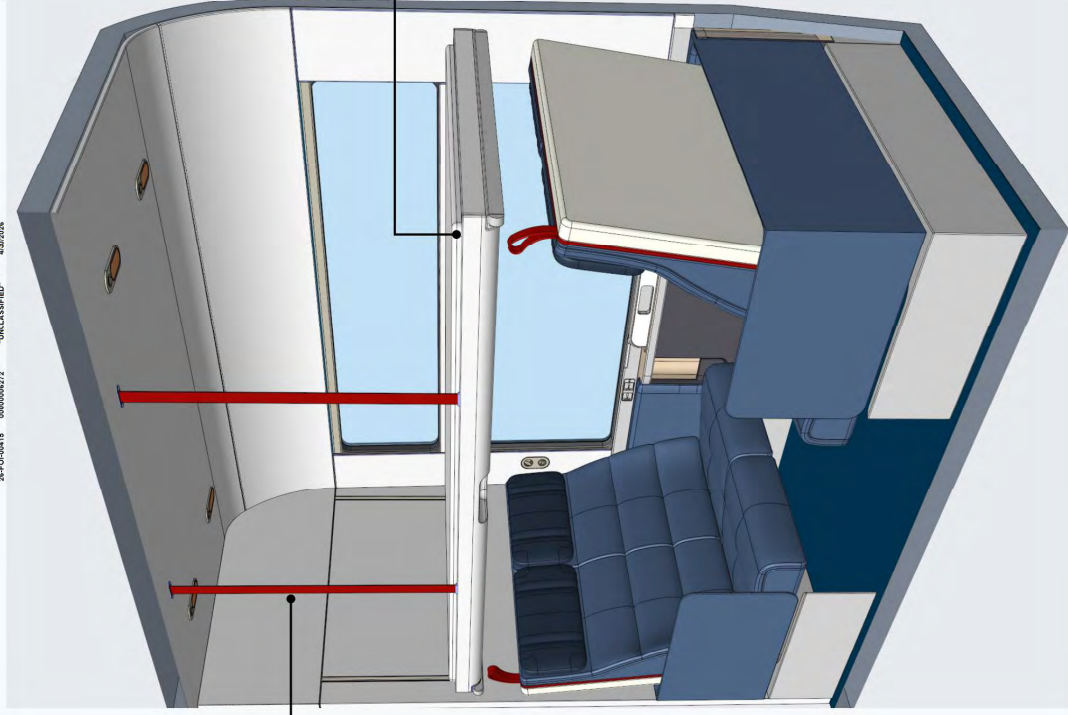

Bunk Retaining Straps

Retaining straps are required to prevent people from rolling out of the bunk. These should retract into the ceiling and be easily pulled down and click into place using an automatic locking retractor belt system (similar to a car seat belt system).

Bunk Height

The bunk height when deployed will be evaluated and judged carefully during the design review process.

The seated area below the bunk should still be usable by seatec passengers when the upper bunk is deployed, the area should still be well lit and tables and other amenities should not be restricted by a deployed bunk.

Club Bedroom | Seat to Bed Conversions

26-PD-10416 000000272 "UNCLASSIFIED" 4/20/2016

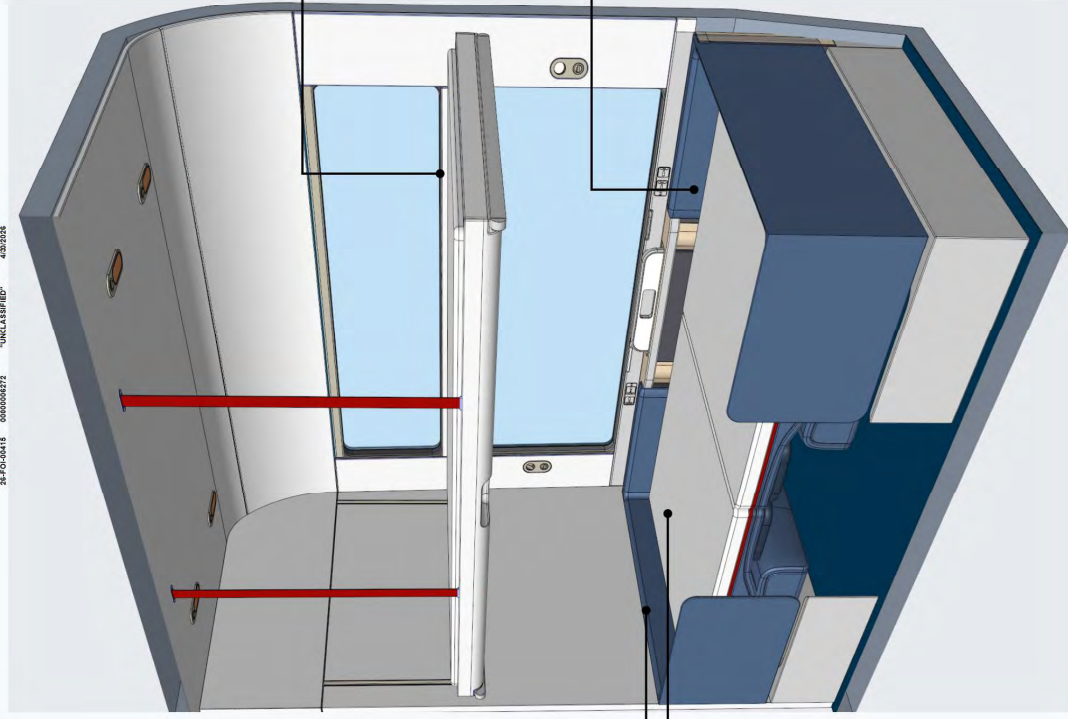

Head Board

The armrest and seat side pad should continue and connect to form a thin soft headboard around the back of the seat when the bed for the lower berth is down.

Lower Berth

Conversion of seats to bed should result in an entirely flat bed surface. The mattress surface should be integral to the seat. A single seam between the bed surface is acceptable with a single thin topper to finish the bed surface.

Bunk Dimensions

Should be maximized to the available width with a minimum width 44" x minimum length of 77".

Lower Berth Dimensions

Should be maximized to the available width with a minimum width 48" x minimum length 77".

Minimum Clear Way

A free clear channel should be provided. Key dimensions and access to the upper bunk will be subject to mockup testing and Amtrak approval.

Handrails and Grabs

Suitable handholds shall be provided to assist people transitioning to the bunk. These should be positioned on both sides of the bunk. Additional handholds may be required to assist people climbing down safely from the bunk, positioned closer to the door of the room.

Steps

At least three integrated steps should be built into the area beside the seat to allow people to safely transition to and from the upper bunk. Step width should be at least 15" wide. Step surfaces shall be free from trip hazards and have an anti-slip finish to the tread surfaces. Steps shall be designed in such a way that the seat cushions, armrests, any soft furnishings are protected and clear of tread surfaces. Design of the steps should discourage people from using the sink surfaces as steps. Step design and access to upper bunk will be subject to mockup testing and the approval of Amtrak.

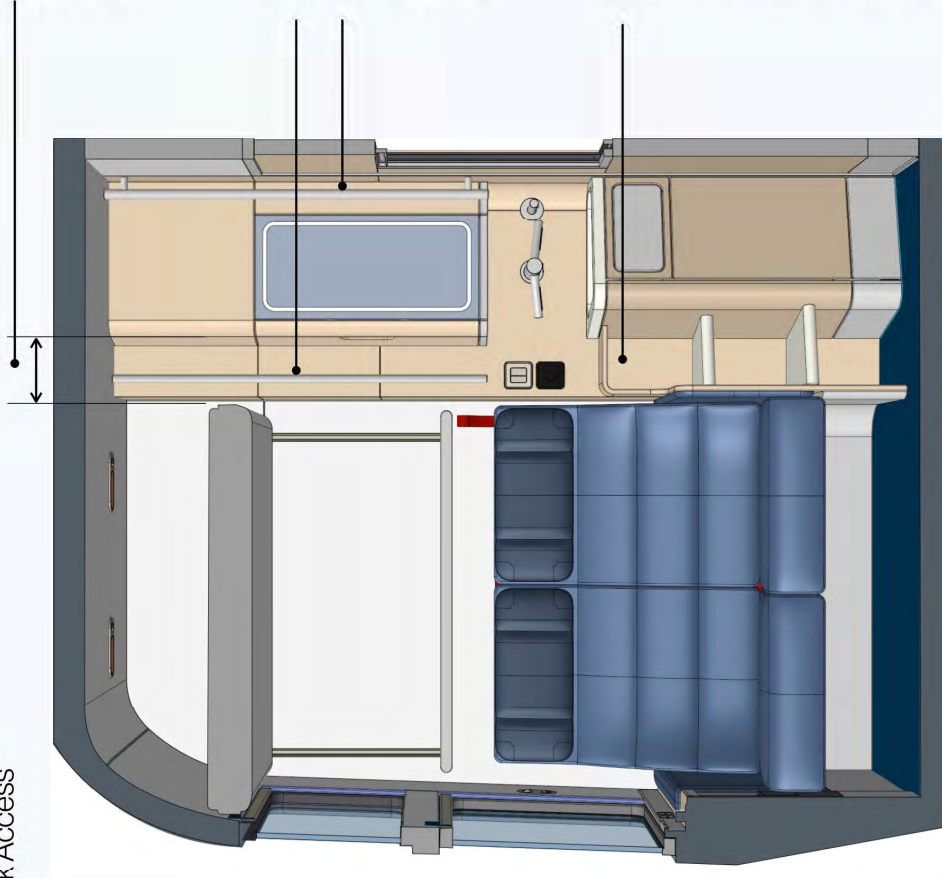



RFI-0416 00000472 UNCLASSIFIED 4/2/24

Club Bedroom | Lighting

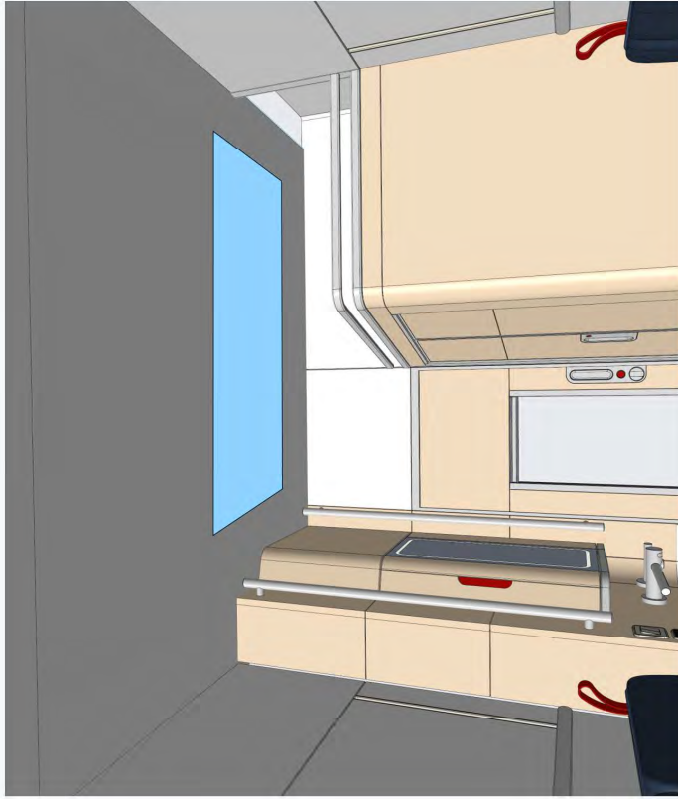

Lobby Lights
Panel lighting provides master ceiling light to the lobby and vanity area.

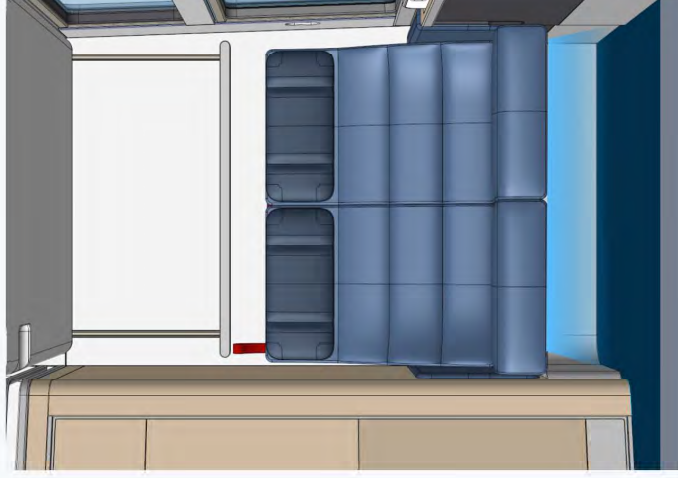

Under Seat Light
Under seat light should be indirect and spill light out across the floor.

*See lighting spec for detailed definition

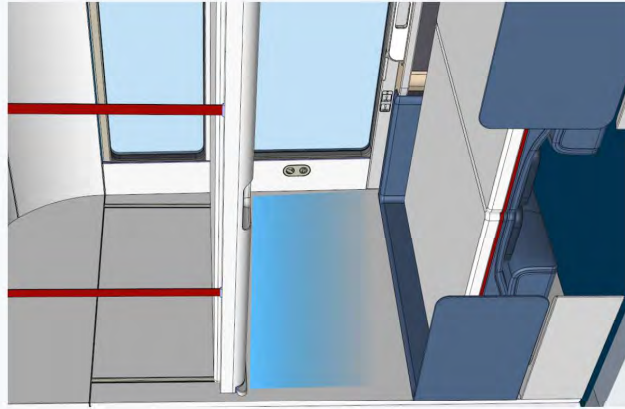

Back Wall Wash Light

Bunk support runner washes indirect light down the end walls on both sides of the room.



Back Wall Wash Light

Bunk support runner washes indirect light up across the end walls on both sides of the room.

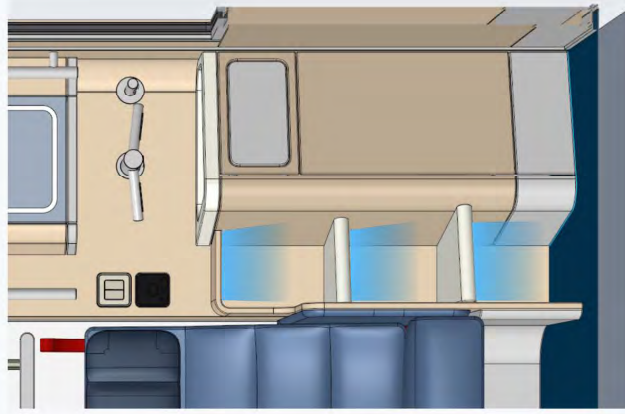

Step Lights

Indirect light provides wash light over each of the steps.

*See lighting spec for detailed definition

Club Bedroom | Lighting

26-PJ-10416 0000004272 "UNCLASSIFIED" 4/20/2016

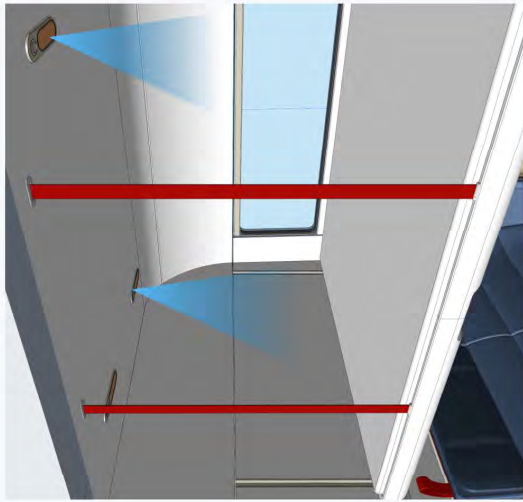

Upper Reading Lights

Reading lights should be provided, embedded in the ceiling above the bunk. These should be mini panel lights. 2 lights in total located at each end of the bed. Light switches should be located next to the reading light.

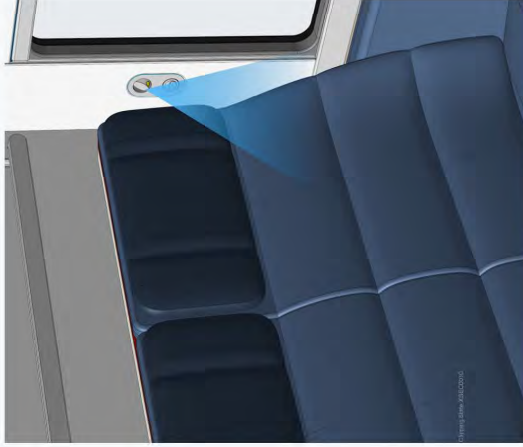

Lower Reading Lights

Reading lights should be provided at each seated location. People should be able to adjust the direction, position the light over their lap to be able to read a book at night. Switches should be located near or on the light.

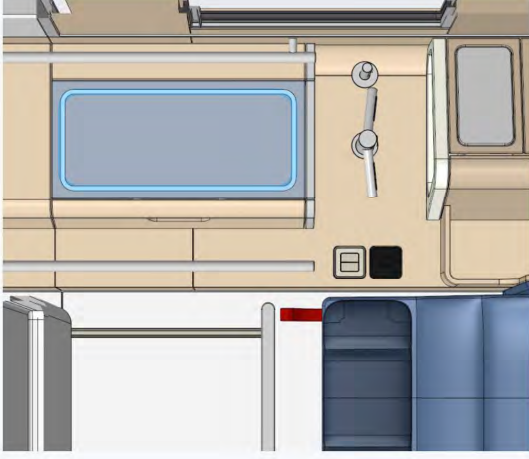

Mirror Light

The vanity mirror is illuminated with a back light or similar.

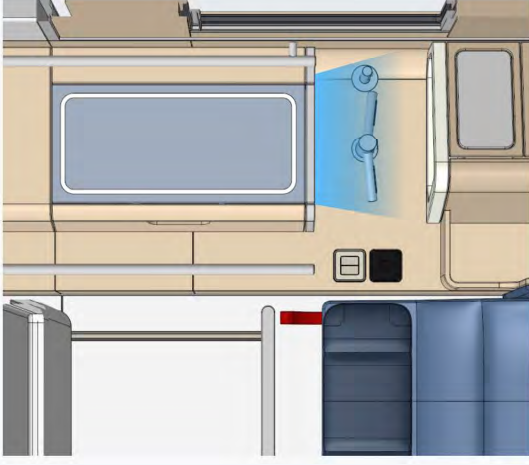

Vanity Light

The vanity surface is illuminated with an indirect lighting.

*See lighting spec for detailed definition



RFI-0416 000004272 UNCLASSIFIED 4/2/24

Club Bedroom | Toilet & Shower

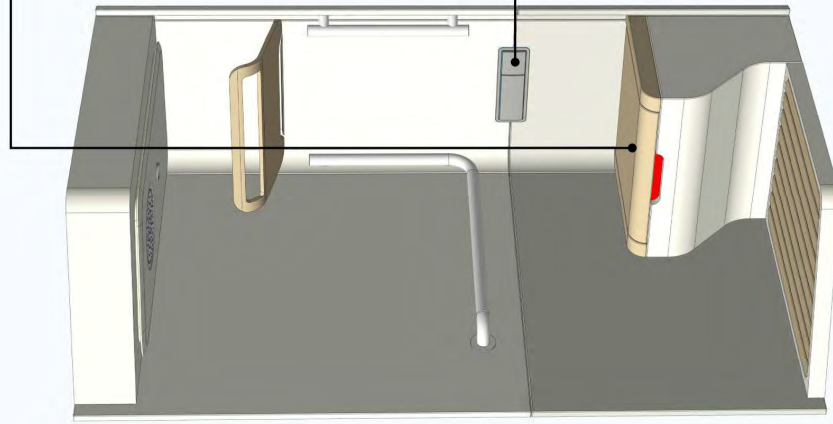

LH Side

Toilet

The toilet is covered by a lid that covers the toilet seat and also acts as a shower seat.

While the bathroom is being used as a shower the lid should disguise the toilet seat forming a bench across the width of the room. The form of the toilet is undercut at the bottom to maximize standing space in the shower area. The design of the toilet, access and lid design will be subject to testing and ergonomic review during mockup stages and subject to the approval of Amtrak.

A separate more standard toilet seat and toilet lid may be required with the shower seat acting as an additional layer with the sole purpose of hiding the toilet and providing a shower seat.

Toilet seat, seat lid and shower seat should all have soft close mechanisms.

Toilet Flush

A two button push flush is located on the back wall providing standard and eco flush.

Toilet Paper Storage

The toilet paper should be stored in the wall of the bathroom with a waterproof cover to protect it from getting wet with shower water.

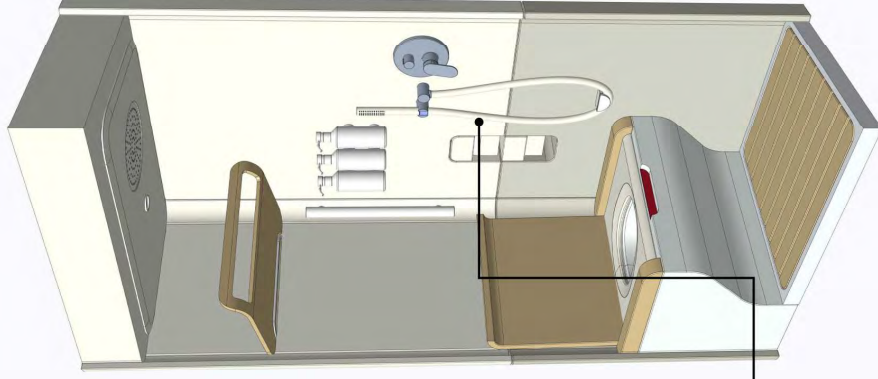

RH Side

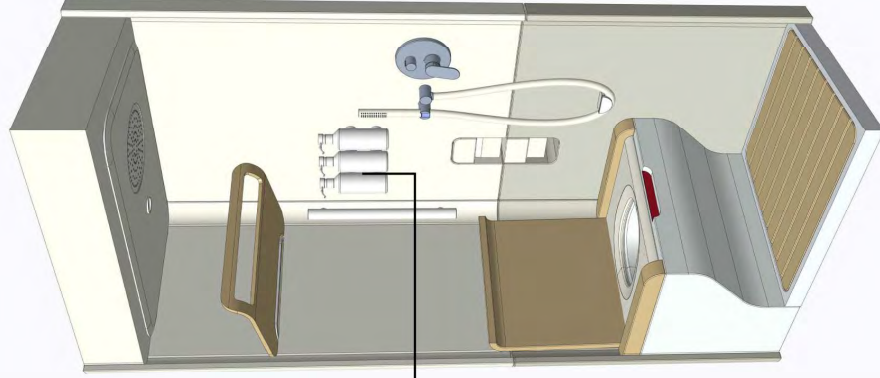

RH Side

Towel Storage

A shelf on the back wall of the bathroom of a suitable size to store a minimum of 4 Amtrak bath towels. The shelf and towels are to be placed high and out of the direction of any shower water when the shower is in use.

Dispensing Bottles

3 refillable Amtrak bottles dispensing shampoo, conditioner and body lotion. Bottles should be fixed to the wall and easily refilled or replaced by Amtrak staff.

Grab Handles

Suitable grab rails should be positioned to aid people while standing in the bathroom for both showering and for use of the toilet. Locations and sizes will be subject to mockup testing and Amtrak approval.

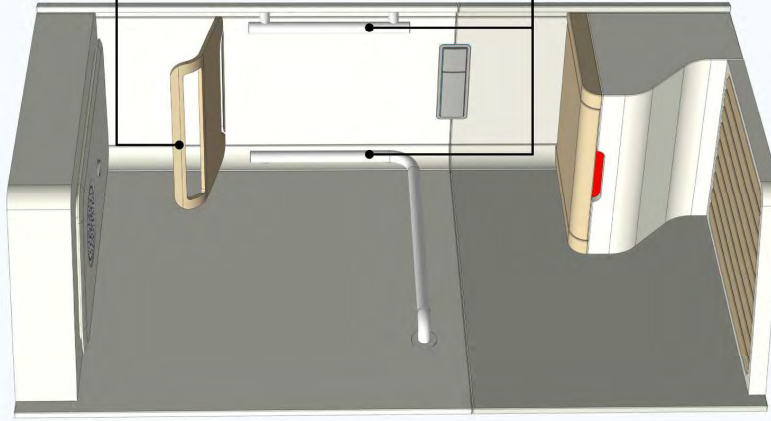

LH Side

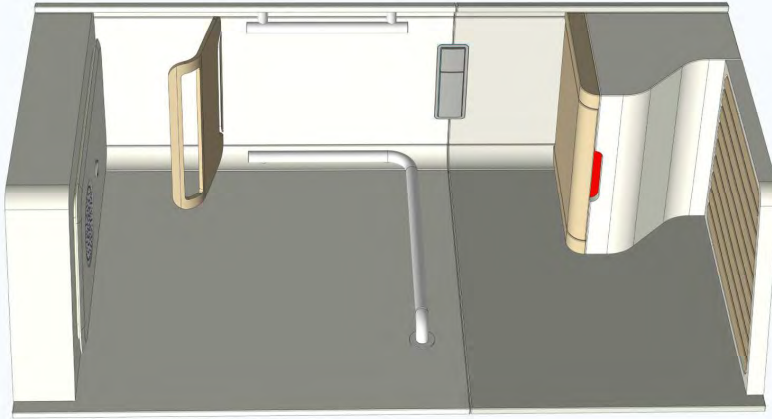

LH Side

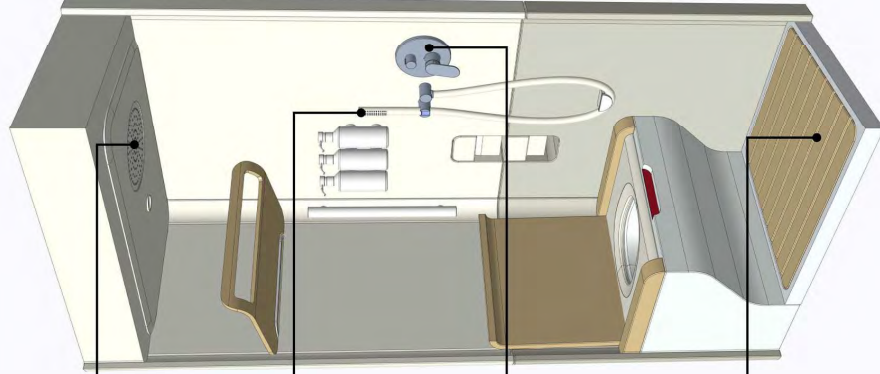

RH Side

Rain Shower

A rain shower in the ceiling provides a shower above head height. Rain shower should be seamlessly integrated into the ceiling in order to maximize head room in the bathroom.

Hand Shower

A second hand shower is located with a slimline design handset. A hose clip should be included to prevent the hose from rattling while the train is in transit.

Shower Control

Shower controls are located on the bathroom wall close to the door. The shower control should prevent any accidental activation when using the toilet.

Drainage

The toilet floor has a built in shower tray with a raised lip. A slatted platform finishes flush with the top of the tray to allow the shower water to drain out underneath and prevent the floor remaining wet after use as a shower. The shower tray should be designed to prevent water from escaping into the main area of the room.

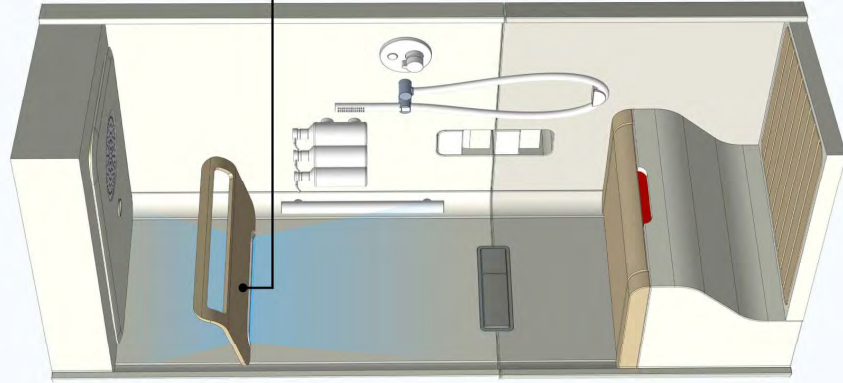

LH Side

Back Wall Wash Light

Shelf runner washes indirect light upwards and underneath the towel shelf.

LED light panel spot

Small circular LED light panels act as spot lights - frame to be color matched.

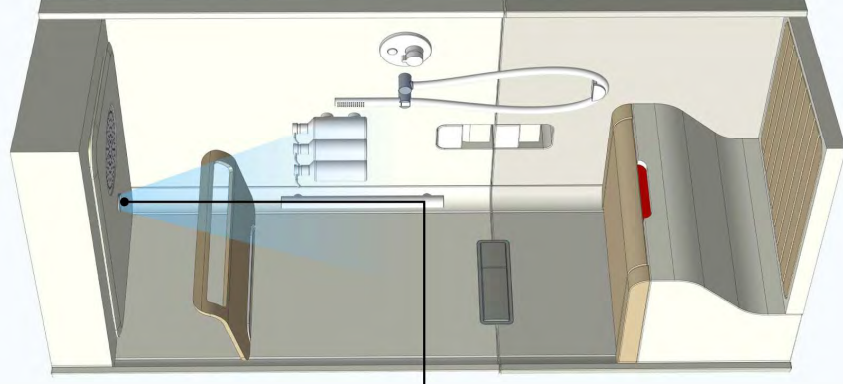

RH Side



254-F010416 000000272 "UNCLASSIFIED" 4/2024

Coach Areas

Sleeper Bedrooms

Food & Beverage

Toilets & Showers

Common Use Areas

Amtrak® Long Distance Product Features

07 | Accessible Bedroom

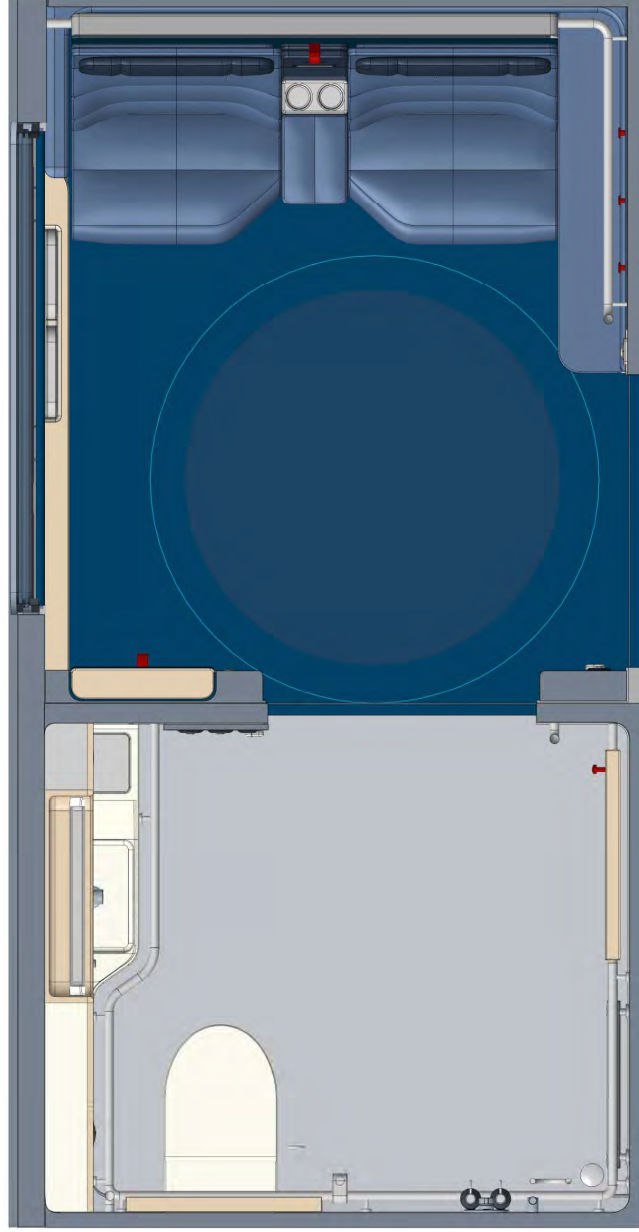

Accessible Bedroom

The Accessible Bedroom is a fully accessible room for three. The room has a double lower berth and a single upper bunk.

The accessible space is based on the RVACC recommendations to accommodate larger mobility devices. The ability to turn around in the room is facilitated by a clear 60" turning circle.

The room has an ensuite bathroom that is also fully accessible with a lockable door separating it from the living space.

Accessible Bedroom | General

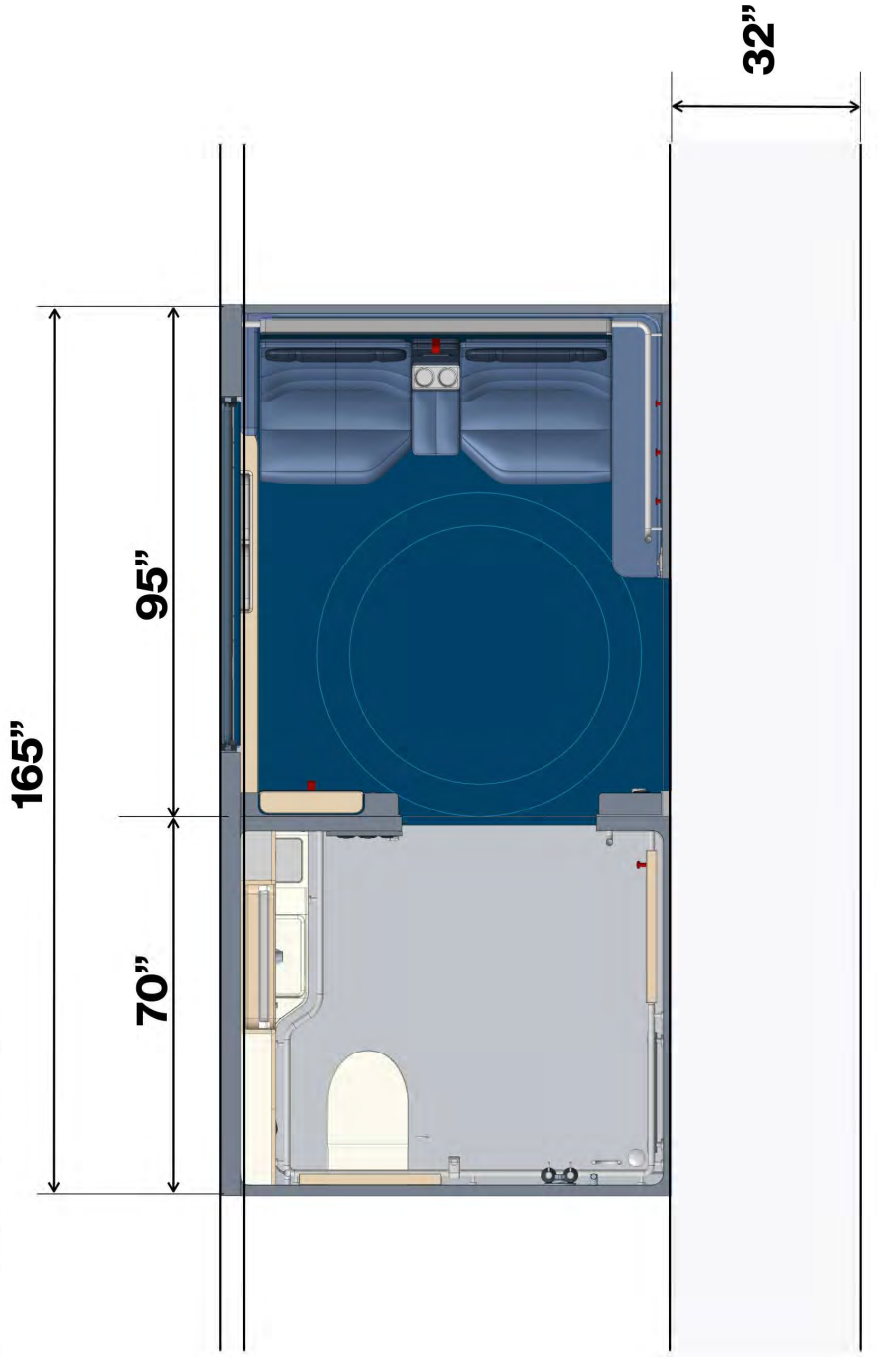

Accessible Bedroom

The Accessible Bedroom should be a maximum of 165" long and designed for a 32" side aisle.



25-F-0416 000004272 UNCLASSIFIED 4/2/2016

Accessible Bedroom | Accessibility

Accessible Bedroom | Accessibility

24-FD-0416 000004272 "UNCLASSIFIED" 4/20/2016

Horizontal Handrail

ADA compliant horizontal handrails positioned adjacent to the aisle side seat to assist transfer into the seat and bed. The handrail should be positioned to maximize the space between the bed and the bottom of the handrail.

Vertical Handrail

ADA compliant vertical handrails positioned either side of the bathroom door to aid transit around the room and into the bathroom.

Horizontal Handrail

ADA compliant horizontal handrails positioned adjacent to the window side seat and accessible space. The handrail should be a minimum compliant distance (33") above the finished floor to reduce impact on the window views. The handrail should not impede the use of the table and cupholders positioned on the sidewall.

39" Room Door

Access to the room will be subject to review and mockup user testing. Room doors should be an automatic sliding door.

Room Door controls

The controls for the room door must be ADA compliant in position, size and configuration. The buttons should be easy and intuitive to use. An accessible manual lock should be included with an indicator to show lock condition. The buttons should have visual and haptic feedback.

36" Bathroom Door

The Bathroom door should be an automatic sliding door. The door should be positioned to create space for a T maneuver when the door is open and the bed is deployed.

Bathroom Door Controls

The controls for the bathroom door must be ADA compliant in position, size and configuration. The buttons should be easy and intuitive to use. The buttons should have visual and haptic feedback. The controls should be positioned away from the main room controls to prevent confusion. Dimensions, position and usability will be subject to Amtrak approval.

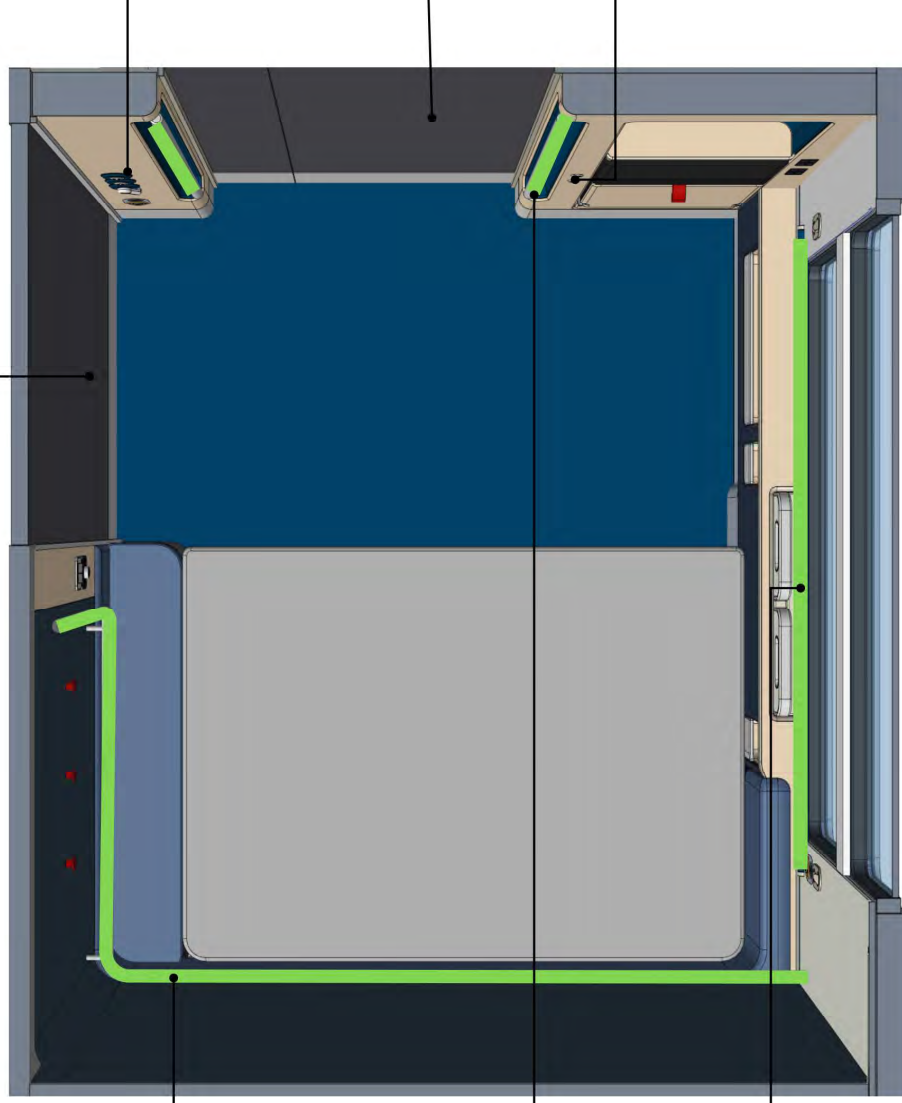

***The position of all Accessible interaction points, turning spaces and clearances will be subject to review, mockups, and user testing**

Accessible Bedroom | Accessibility

25-FD-0416 000004272 "UNCLASSIFIED" 4/20/2016



Vertical Handrail

ADA compliant vertical handrails positioned on should aid bunk access.

Horizontal Handrail

ADA compliant horizontal handrails should be usable at the threshold of the room and assist people who wish to transfer from a wheelchair.

***The position of all Accessible interaction points, turning spaces and clearances will be subject to review, mockups, and user testing**

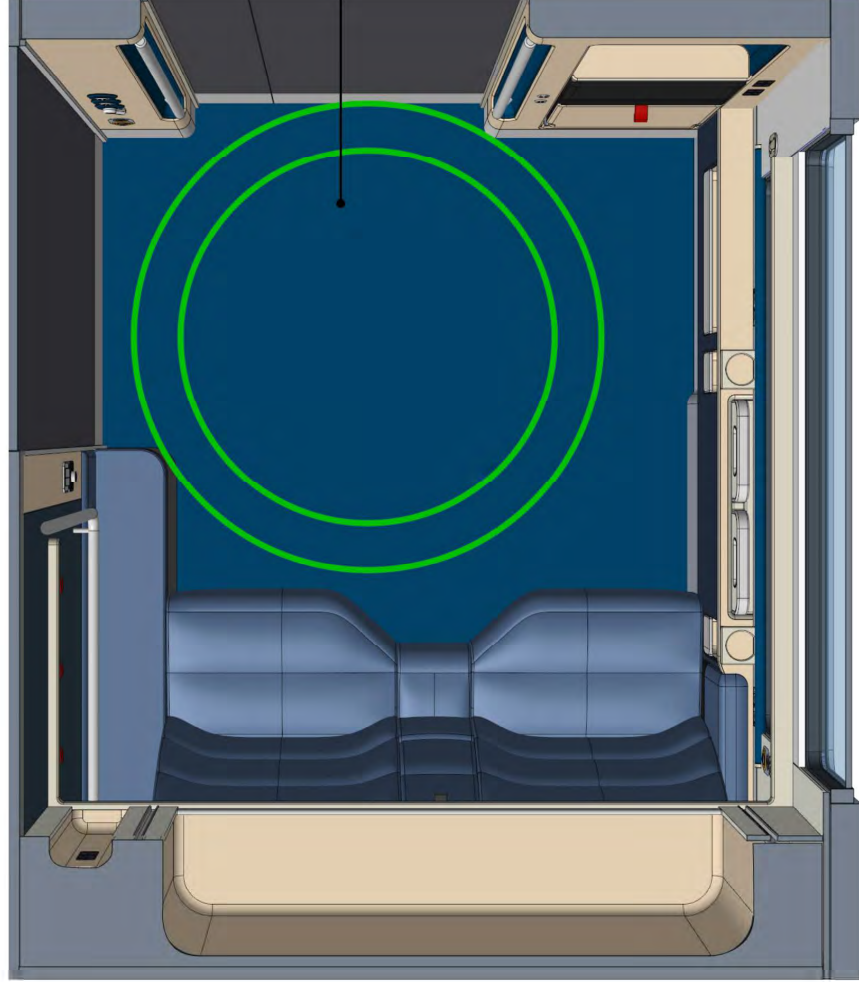

60" Turning Circle

A clear 60" turning circle should be provided inside the room when the seats are in an upright position.

***The position of all Accessible interaction points, turning spaces and clearances will be subject to review, mockups, and user testing**

Accessible Bedroom | Accessibility

25-FD-0416 000004272 "UNCLASSIFIED" 4/20/2016

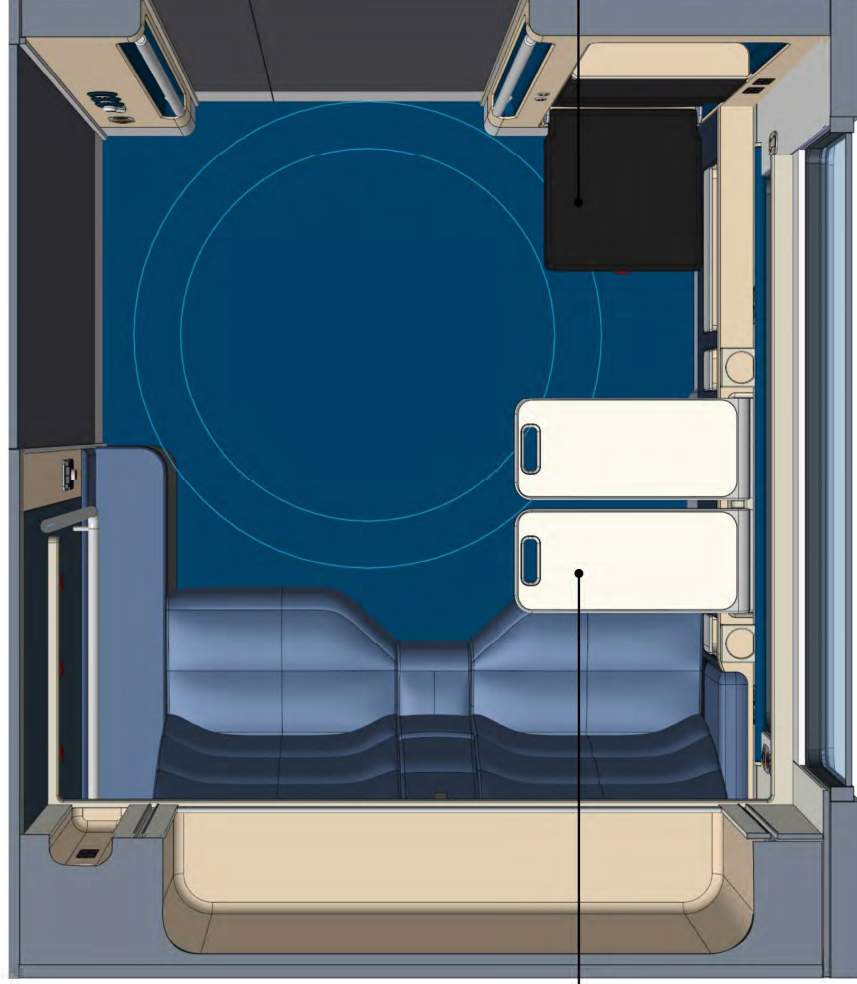

Fold Out Table Clearance
The 60" turning circle should be clear when fold out table is deployed.

Tip-up Seat Clearance
The 60" turning circle should be clear when the tip-up seat is deployed.

***The position of all Accessible interaction points, turning spaces and clearances will be subject to review, mockups, and user testing**

Accessible Bedroom | Accessibility

25-FD-0416 000004272 "UNCLASSIFIED" 4/20/2016

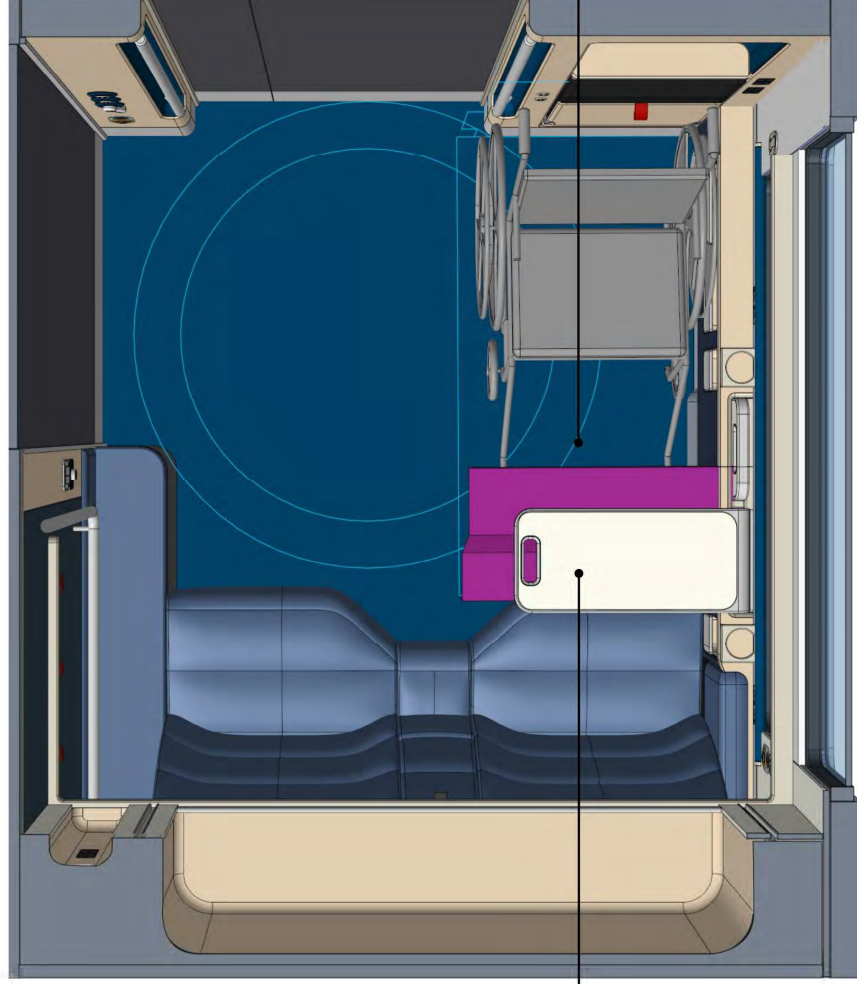

Fold Out Table
Fold out table should be positioned so when deployed it is clear of an RVAC accessible space and an ADA accessible space.

RVAC Accessible Space
A clear accessible space of 59" x 32" should be provided inside the room when the seats are in an upright position.

***The position of all Accessible interaction points, turning spaces and clearances will be subject to review, mockups, and user testing**

Accessible Bedroom | Accessibility

26-FD-00416 000000272 "UNCLASSIFIED" 4/20/2016

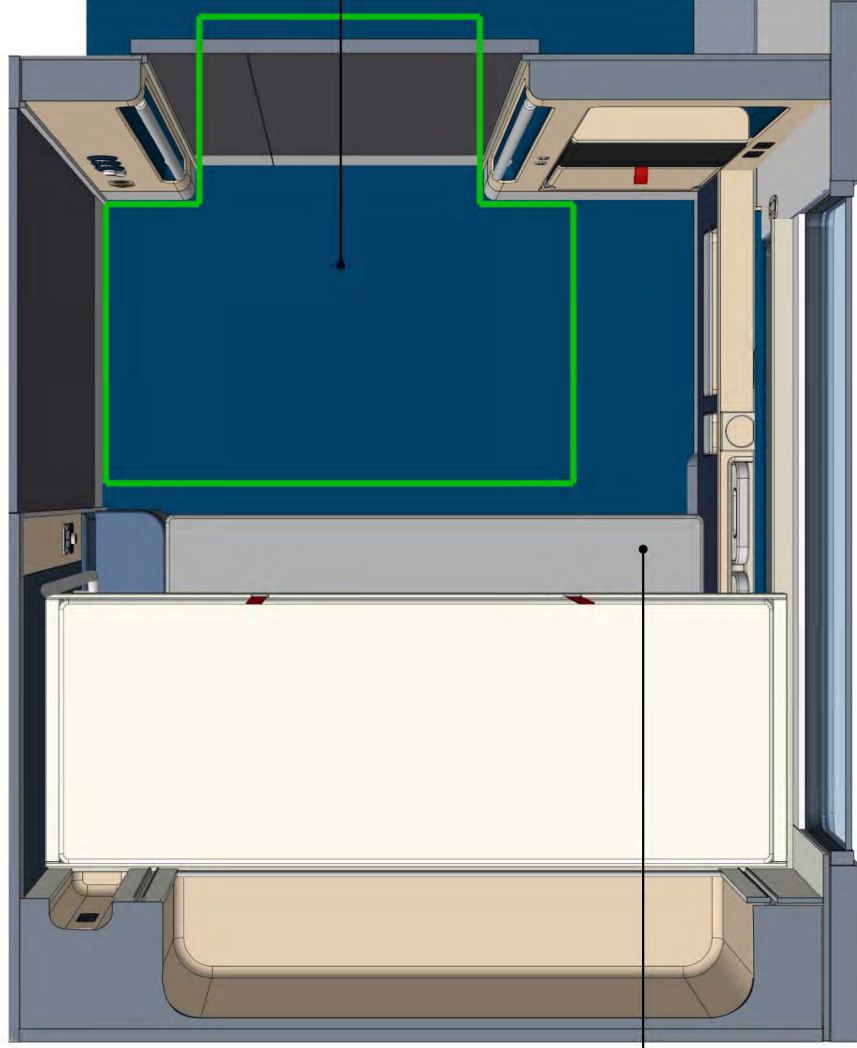

Turning Space

Space should be provided with a 60" turning circle or ADA-approved T-manuever when the lower berth is deployed.

Ladder Clearance

The turning area should be clear when the bunk ladder is attached on the window side.

***The position of all Accessible interaction points, turning spaces and clearances will be subject to review, mockups, and user testing**

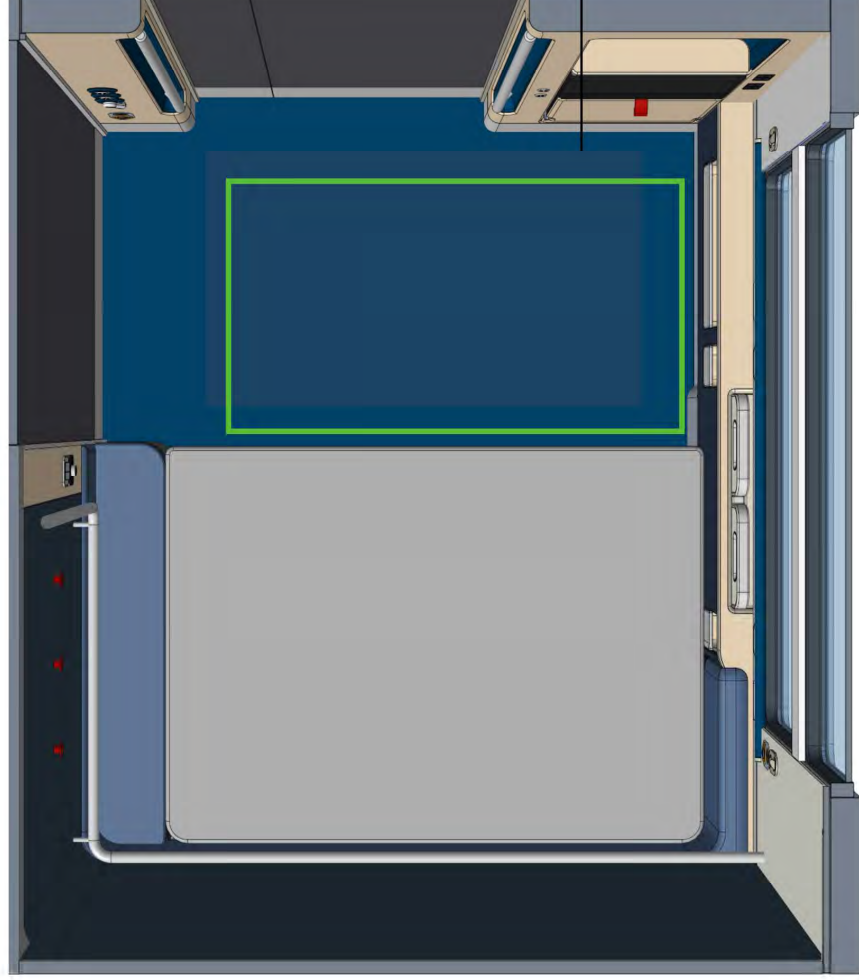

RVACC Accessible Space
An RVACC accessible space of 59" x 32" should be provided for storing a wheelchair beside the bed.

*The position of all Accessible interaction points, turning spaces and clearances will be subject to review, mockups, and user testing



25-F-01415 000004272 "UNCLASSIFIED" 4/20/24

Accessible Bedroom | Features

Accessible Bedroom | Features

25-FD-0416 000004272 "UNCLASSIFIED" 4/20/2016

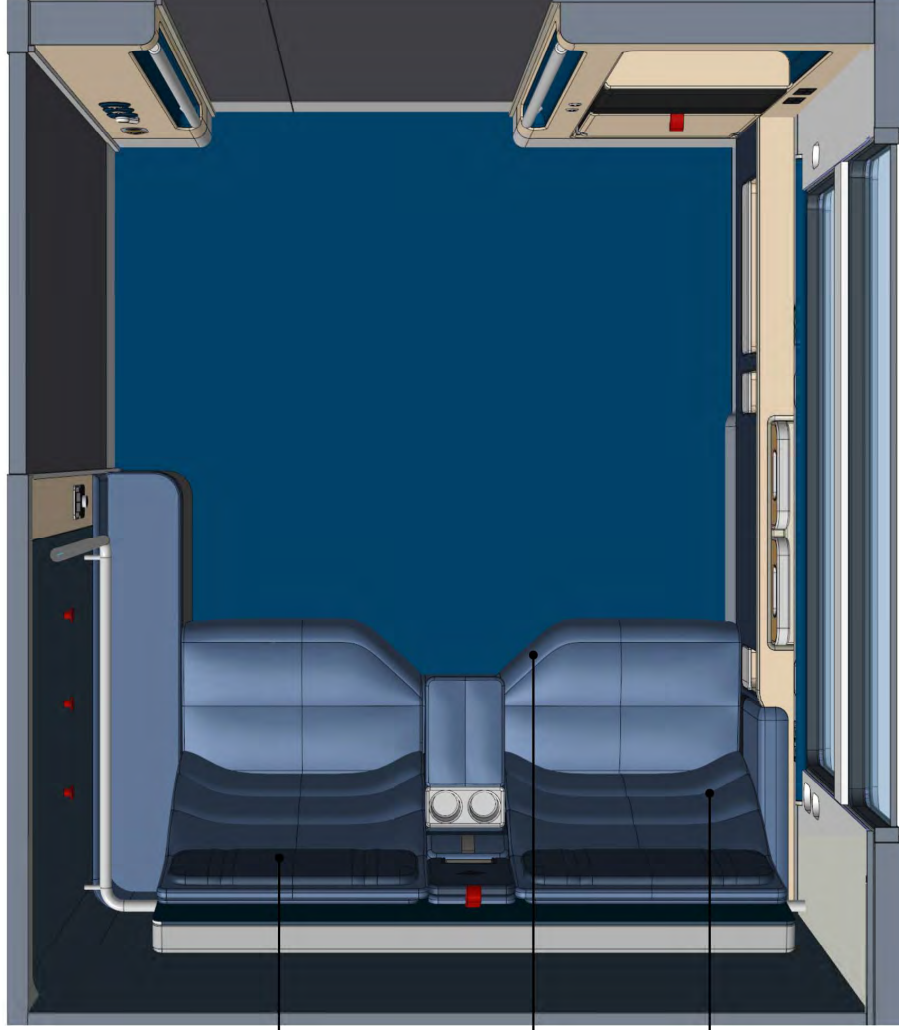

Seat Headrests

Seat headrest should be adjustable in height for a range of people sizes and have adjustable wings that fold outwards to adjust the width of the headrest.

Seat Shape

The seat shape should be optimized to maximize clear floor area, aid wheelchair transfer, and facilitate an accessible, self-sufficient bed deployment.

Seat Comfort

Seat cushions should be contoured to aid seat comfort.

Accessible Bedroom | Features

25-FD-0416 000004272 "UNCLASSIFIED" 4/20/2016

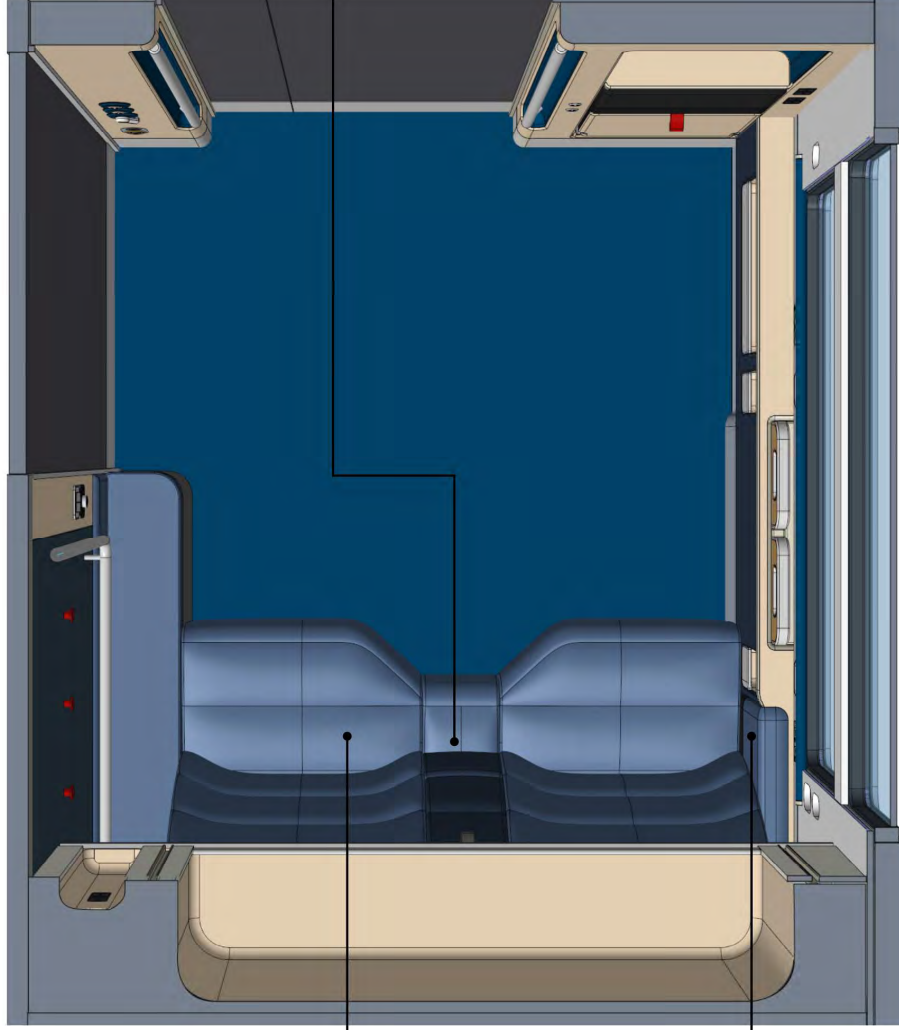

Seat Dimensions

Each seat should have a minimum width of 28" between the inside armrests and the central armrest.

Center Armrest

A full and cushioned armrest should be provided between the two seats. The armrest should have provision for two cup holders.

Armrest

A full and cushioned armrest of 3.5" should be provided on the windows side. The armrest should be of a suitable length for a seated passenger to rest their forearm on the cushioned section.

Accessible Bedroom | Features

Seat Dimensions

All seat dimensions, cushion density/shore hardness will be subject to mockup review and approval by Amtrak.

94-PD-0416 000004272 UNCLASSIFIED 4/20/24

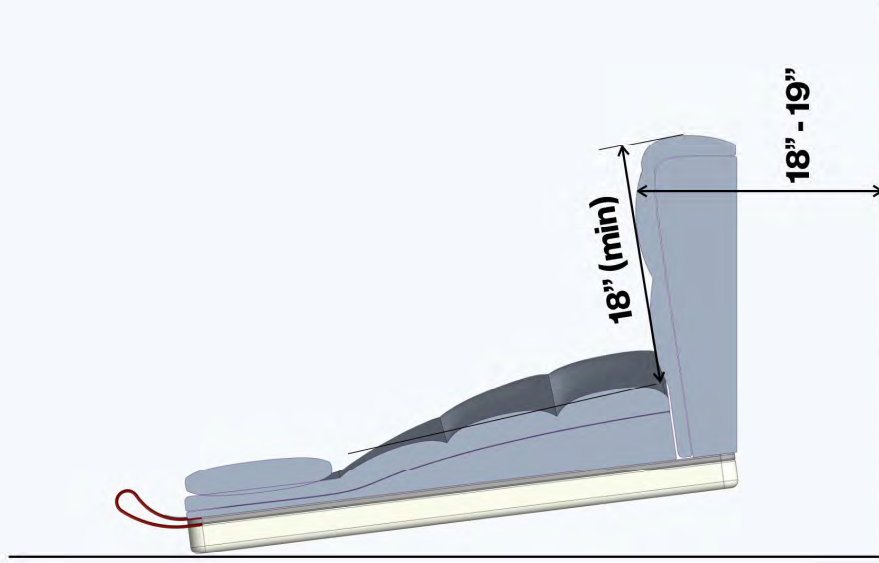

DRAWINGS NOT TO SCALE

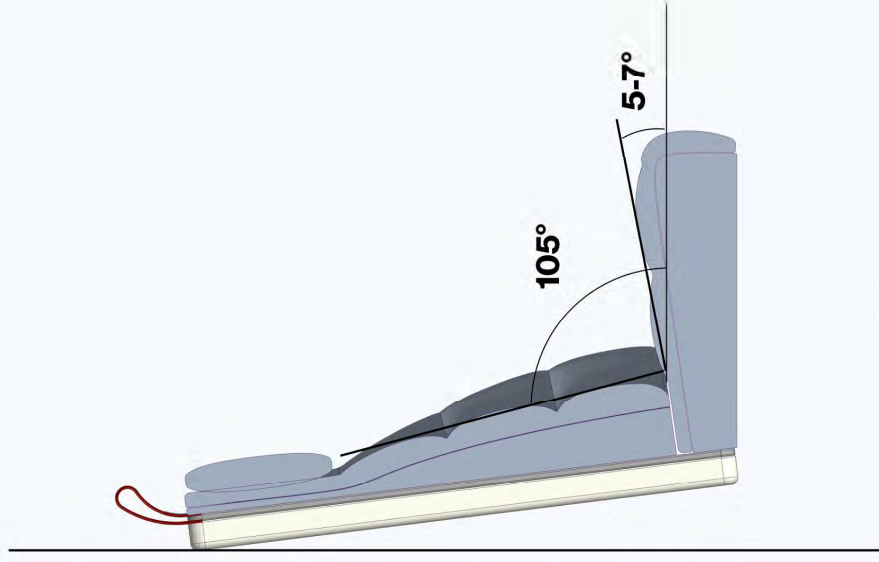

DRAWINGS NOT TO SCALE

Accessible Bedroom | Features

26-FD-0416 000004272 "UNCLASSIFIED" 4/20/2016

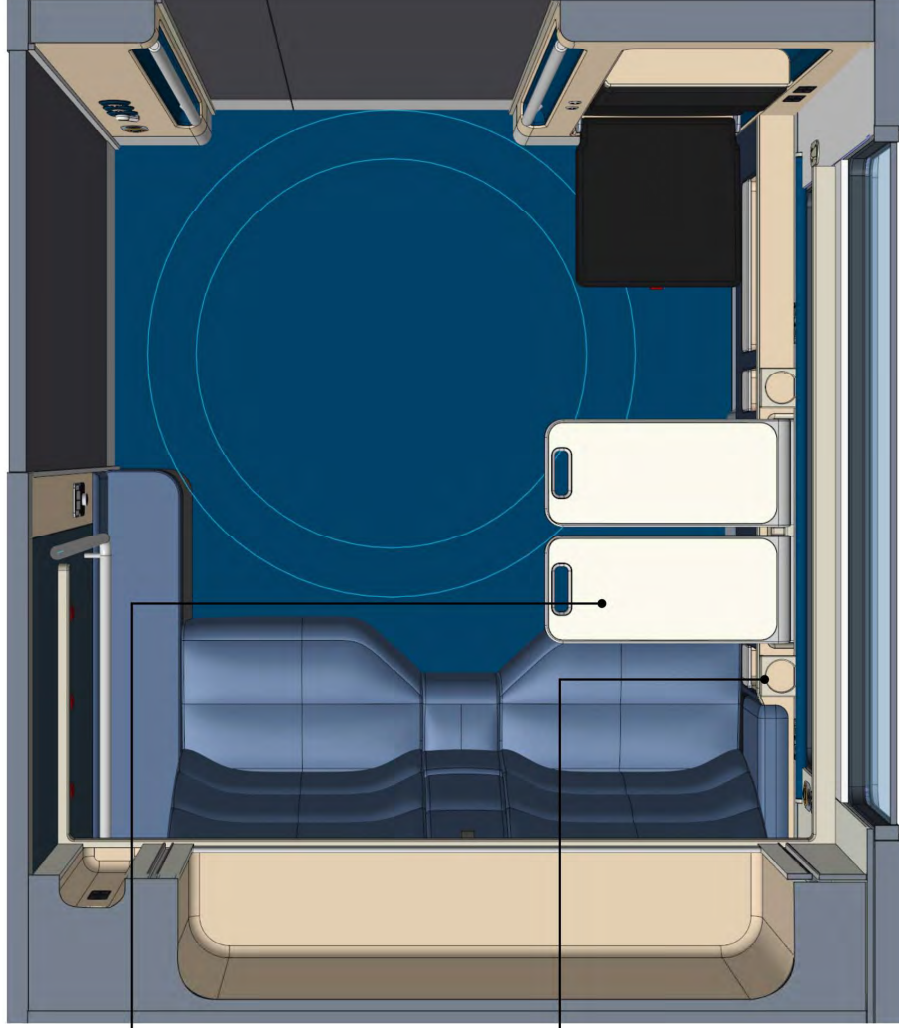

Fold Out Tables
Fold out table should be provide clearance for mobility devices of different sizes while also providing a good table surface for a person sat in the fold out seat.

Cup Holders
Two cupholders located so people can use and access the cupholders from a seated position and can fold away when not in use.

Accessible Bedroom | Features

26-FD-10416 0000004272 "UNCLASSIFIED" 4/20/2016

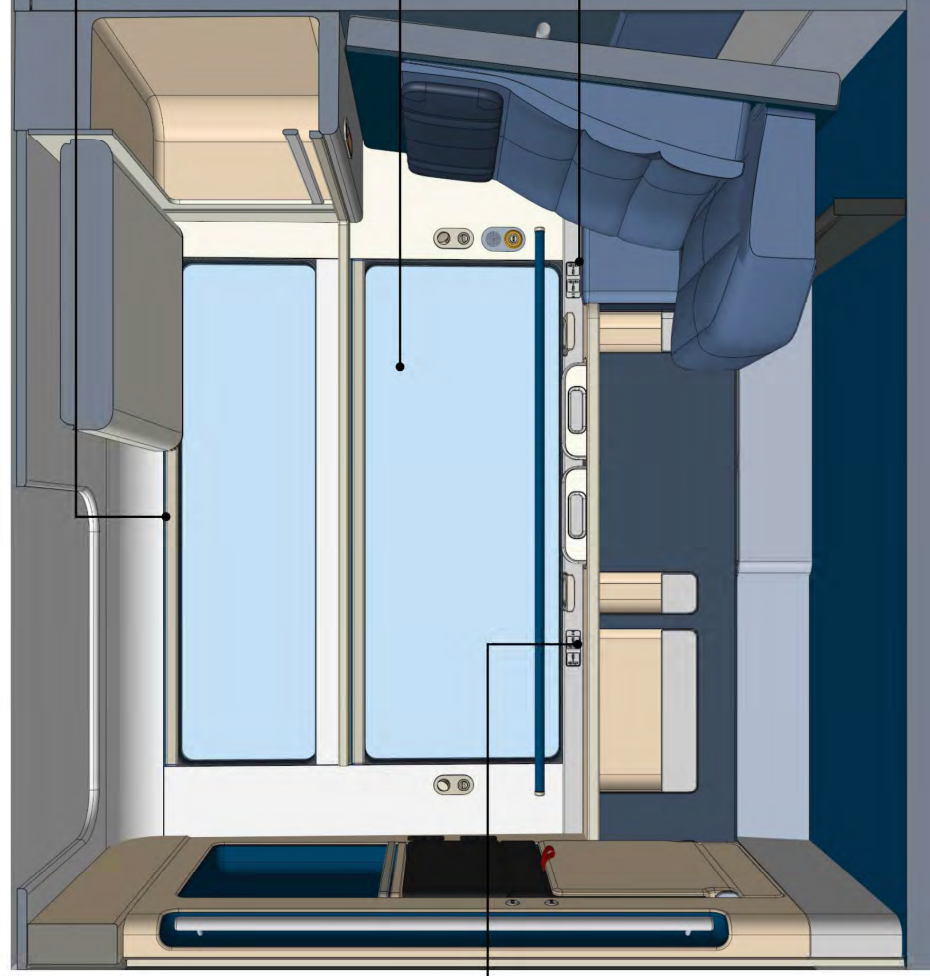

Blinds

A single pull-down blind system shall be provided per window, capable of delivering both daytime solar/glare control and full blackout performance.

Window and Window Mask

Window and window mask should be positioned so each seated position has clear views with the overall window size maximized.

At Seat Power

Two power sockets and two USB sockets should be provided to each seated location. The position should be above the armrest height and in easy reach of people while seated.

Accessible Seat Power

Two power sockets and two USB sockets should be provided near the accessible space suitable for charging an electric wheelchair. The position should comply with ADA and be clear and intuitive to use.

Accessible Bedroom | Features

26-FD-0416 000004272 "UNCLASSIFIED" 4/20/2016

Bunk Power Outlet

Two power sockets and two USB ports shall be accessible from the top bunk when the bunk is deployed.

Lower Berth Power Outlet

Two power sockets and two USB ports positioned in the lower cubby. The outlet should be ADA compliant reach when passengers are seated and accessible from the lower berth when the bed is deployed.



Accessible Bedroom | Features

26-FD-10416 0000004272 "UNCLASSIFIED" 4/20/2016

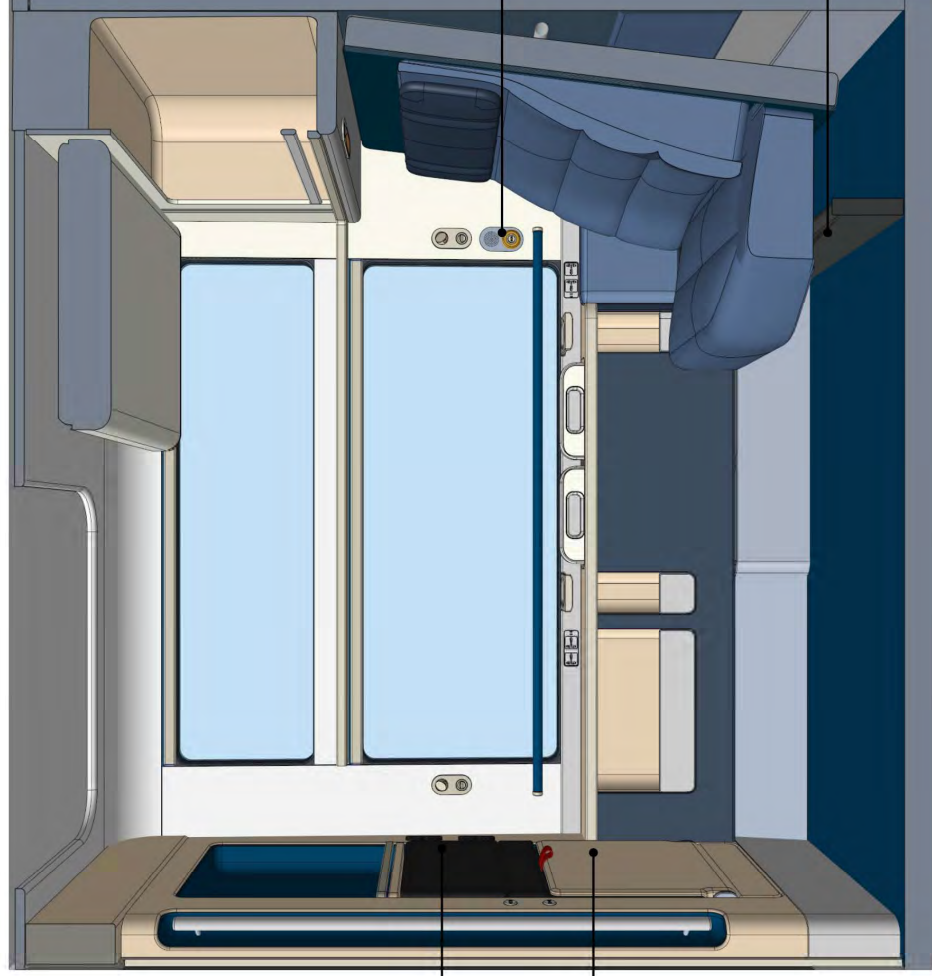

Tip-up Seat

Tip up seat should fold up flush with the side wall to provide a clear and unobstructed space for wheelchairs. Spaces when folded should be durable and suitable to back a wheelchair against.

When deployed the seat should reveal a soft cushioned seat back and headrest so when deployed should have similar comfort levels as the other seats in the room. The seat should be positioned to have good access to the fold out table with a minimum seat width of 21" and minimum seat pan depth of 19".

Call for Aid

Provision for call for aid by seat - locations for all call for aids are subject for review and in compliance with ADA regulations detailed in technical specification.

Under Seat Clearance

Space under the seat can be used to provide clearance for wheelchair.

Accessible Bedroom | Features

25-FD-0416 000004272 "UNCLASSIFIED" 4/20/2016



Doors
Door free from rattle, smooth sliding operation.

Master Light Switch
Master light switches to be positioned near the door. A second master switch should be safely accessible by a person lying in the bed. The position of light switches should be ADA compliant.

Temperature Control



25-F010416 000004272 "UNCLASSIFIED" 4/20/24

Accessible Bedroom | Storage

Accessible Bedroom | Storage

25-F-010416 0000004272 "UNCLASSIFIED" 4/20/2016

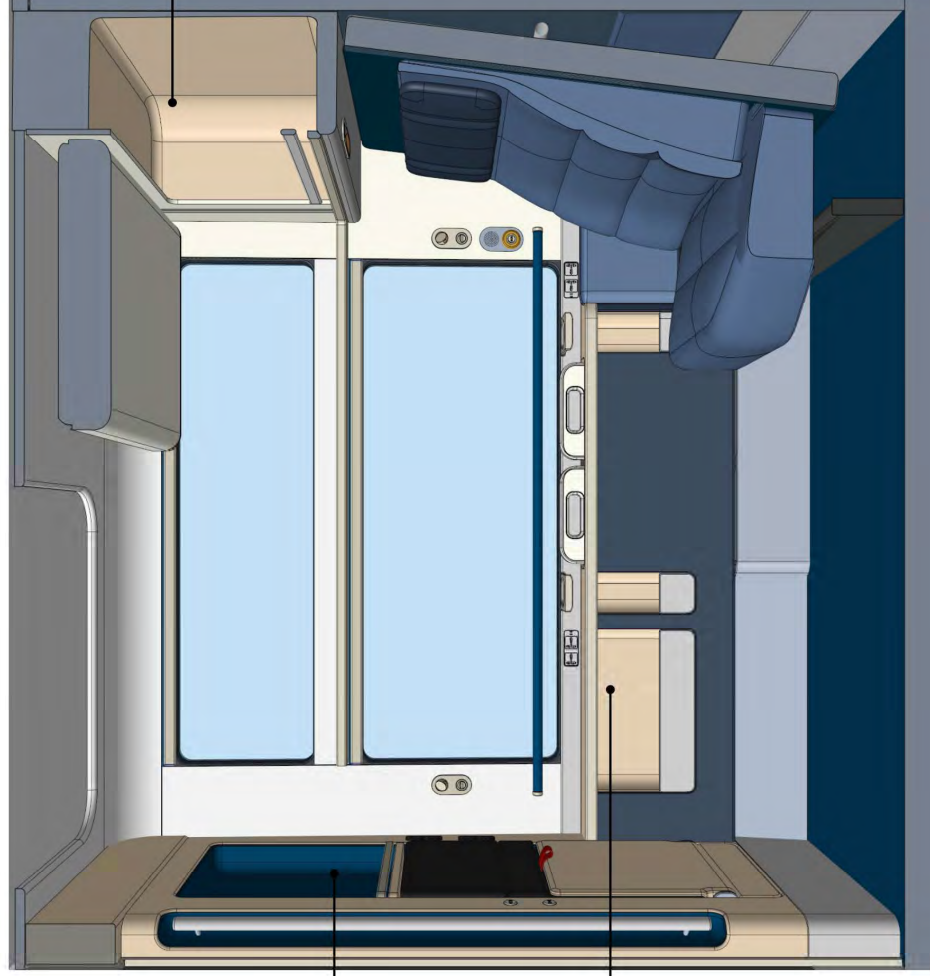

Upper Storage
Upper Storage shall be provided for carry on baggage.

Upper Cubbies
Upper Cubbies shall be provided for personal items.

Cubbies
Sidewall cubbies adjacent to the accessible space and seat shall be provided for storage for personal items.

Accessible Bedroom | Storage

25-FD-10416 0000004272 "UNCLASSIFIED" 4/20/2016



Bunk Cubby

Bunk cubbies provide storage for personal items. Usable when bunk is stored and also provides storage for upper bunk when bunk is deployed.

Hanging Space

At least two coat hooks should be provided on the inner wall, suitable to hang clothes or provide the function of an open wardrobe. The lower hook should be accessible for a person using a wheelchair at a maximum of 48" from the finish floor.

Lower Storage

Storage for carry on baggage shall be provided at an accessible lower level beside or under the seating area.



25-FD-0416 000004272 "UNCLASSIFIED" 4/20/24

Accessible Bedroom | Seat to Bed Conversions

Accessible Bedroom | Seat to Bed Conversions

26-FD-04116 000000272 "UNCLASSIFIED" 4/20/2016

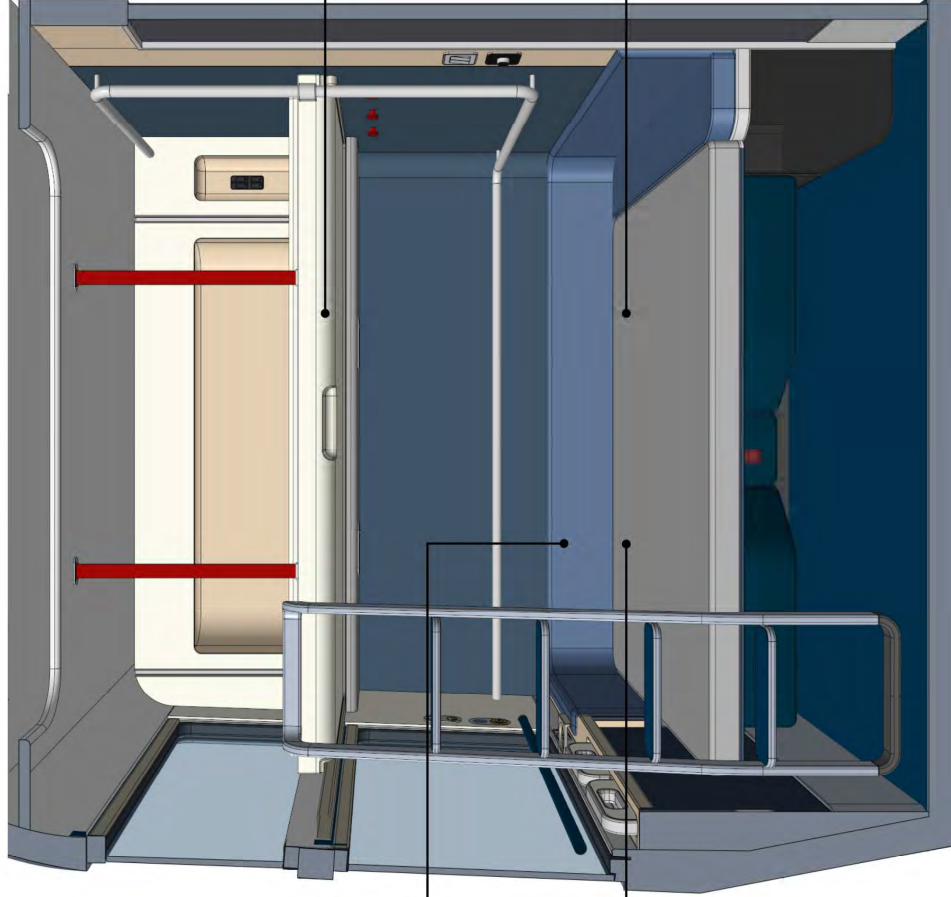

Bed Headboard

The armrest and ottoman side pad should continue and connect to form a thin soft wrap around the bed.

Lower Berth

Conversion of seat to bed should result in an entirely flat bed surface. The mattress surface should be integral to the seat. A single seam between the bed surface and the Ottoman is acceptable. A single thin topper will finish the bed surface.

Bunk Dimensions

Minimum width 28" x Minimum length 76".

Lower Berth Dimensions

Minimum width 48" x minimum length 73" when combined with the Ottoman.

Accessible Bedroom | Seat to Bed Conversions

24-FD-10416 0000004272 "UNCLASSIFIED" 4/20/2016

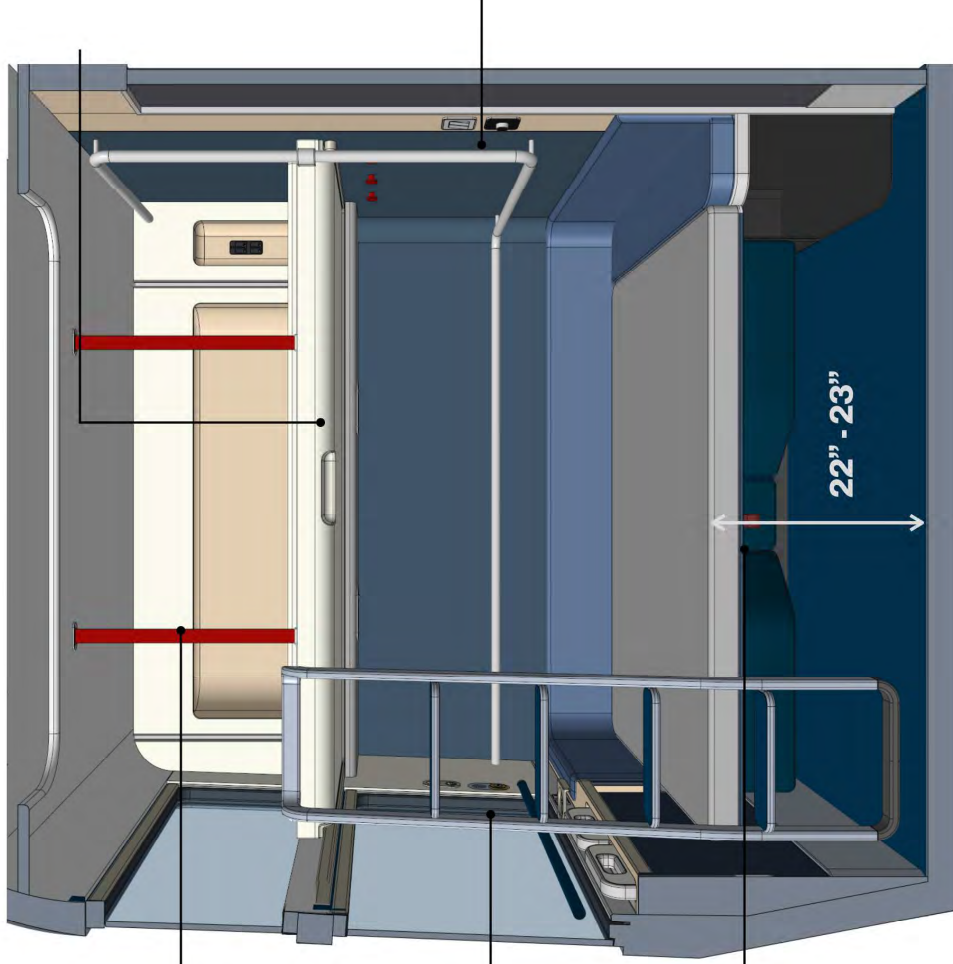

Bunk Retaining Straps

Retaining straps are required to prevent people from rolling out of the bunk. These should retract into the ceiling and be easily pulled down and click into place using an automatic locking retractor belt system (similar to a car seat belt system).

Ladder Dimensions

The ladder dimensions should comply with the relevant standard.

Deployed bed height

The deployed bed height shall be between 22" and 23"

Bunk Height

The bunk height when deployed will be evaluated and judged carefully during the design review process.

The seated area below the bunk should still be usable by seated passengers when the upper bunk is deployed. The area should still be well lit and tables and other amenities should not be restricted by a deployed bunk bed.

Handrails and Grabs

Suitable handholds shall be provided to assist people transitioning on both sides to the bunk. Additional handholds may be required to assist people climbing down safely from the bunk.

Accessible Bedroom | Seat to Bed Conversions

25-FD-10415 000000272 "UNCLASSIFIED" 4/20/2016

Ladder

The ladder is stored in the bunk. It should be durable and lightweight. It should not have any sharp corners or edges. It must be intuitive to use and locate. The fixation method should be robust and easy to lock and unlock. Successful locking should be visually indicated and safety measures should be put in place to prevent accidental unlatching and prevent misuse. The ladder should be usable in multiple positions based on user specific needs and preference. Each step should clearly contrast the floor and it should also have integrated battery powered lights for safe use during low level light conditions.

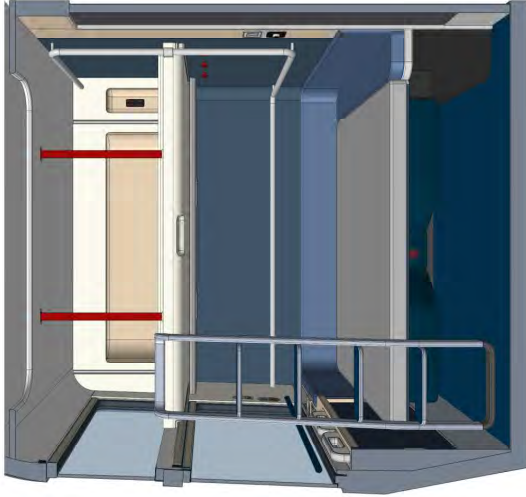

Ladder position 1

Maintains a 60° turning circle on the floor.

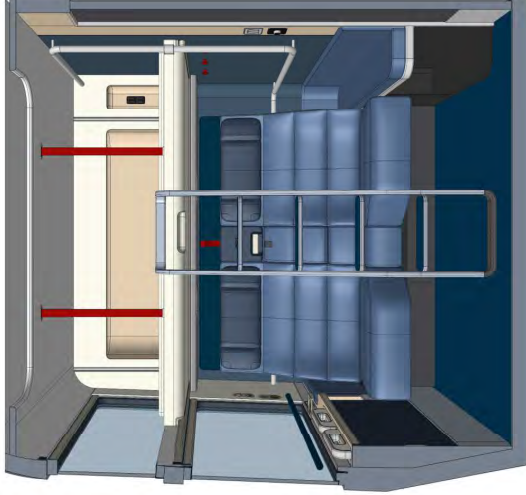

Ladder position 2

Bunk down and a passenger in both seats.



Ladder position 3

Accessible space clear and one seat occupied.

Accessible Bedroom | Seat to Bed Conversions

25-FD-0416 000004272 "UNCLASSIFIED" 4/20/2016

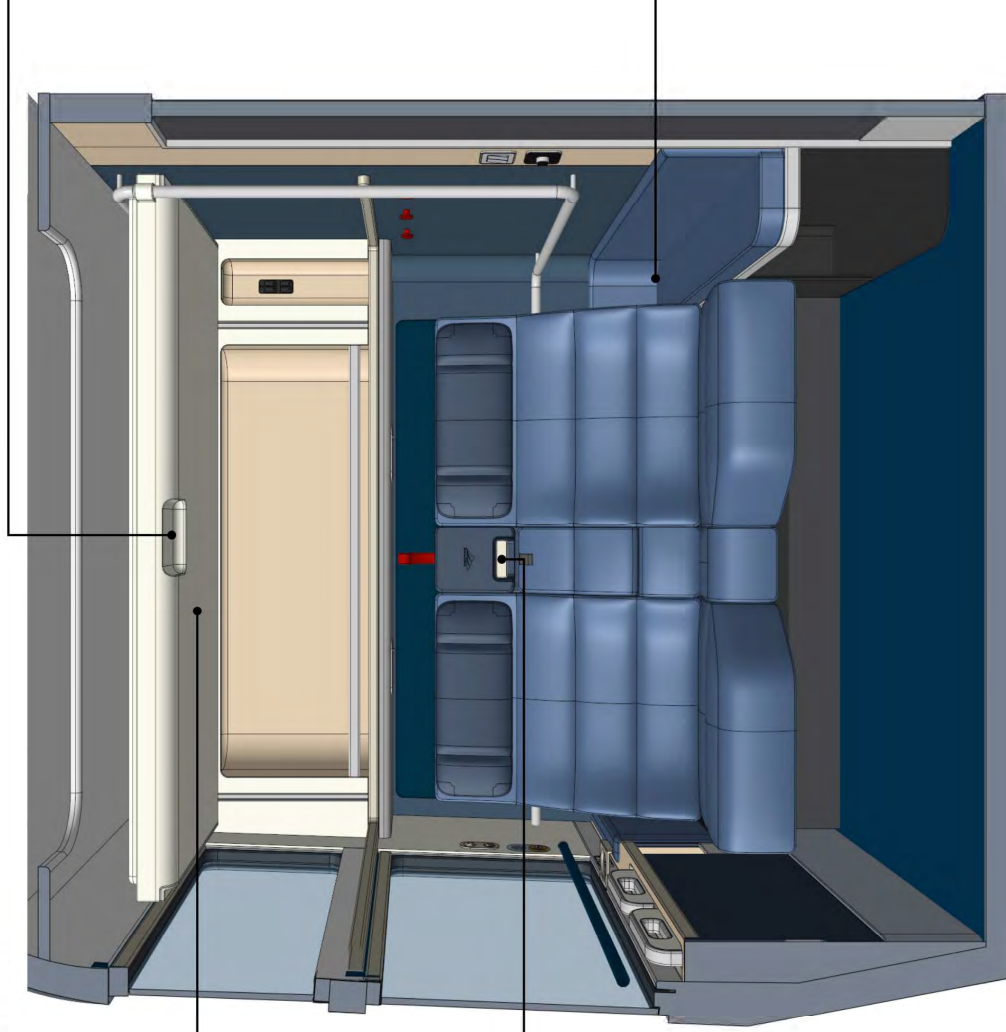

Upper Bunk

Bunk should be stored horizontally at the maximum height in the room. Bunk should not preclude any part of the window when stowed. The bunk's stored height should be maximized so head clearance is maximized in both seated and standing positions.

Upper Bunk Deployment

A simple and easy to use handle, latch and lock mechanism should be within easy reach from a standing position. Successful locking should be visually indicated and safety measures should be put in place to prevent accidental deployment and prevent misuse.

The bunk deployment should be free from jamming and racking and should lower slowly and in a controlled manner. Considerations should be made for assisted movement or counter balances to assist people moving the bunk down and back up into the stowed position.

Lower Berth Deployment

A simple unlatch mechanism is required to convert the seats into a lower bed/berth. This should be positioned in a place that is easy for people to use and designed in a way so that people can understand its purpose. The position should be ADA compliant and within reach of a person using a wheelchair. Controls and operating mechanisms shall be operable with one hand and shall not require tight grasping, pinching, or twisting of the wrist. There should be an assisted mechanism making it easy for passengers of any ability to self-sufficiently and safely deploy and store the bed.

Ottoman

An ottoman can be provided by the side of the seats to form part of the bed surface. The top surface can be used as additional storage during the day. Carry on stowage can be stored under the ottoman.

Accessible Bedroom | Seat to Bed Conversions

26-FD-0416 000004272 UNCLASSIFIED 4/20/2016

Bed Dimensions

All bed dimensions, mattress densities will be subject to mockup review and approval by Amtrak.

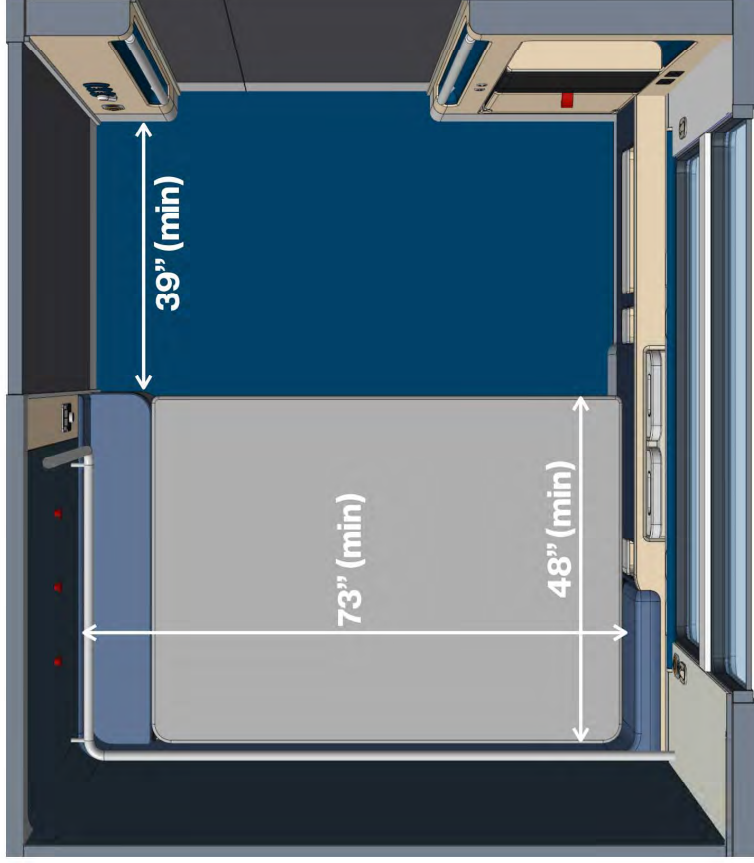

Accessible Bedroom | Seat to Bed Conversions

26-FD-0416 000004272 "UNCLASSIFIED" 4/20/2016

Bed Dimensions

All bed dimensions, mattress densities will be subject to mockup review and approval by Amtrak.

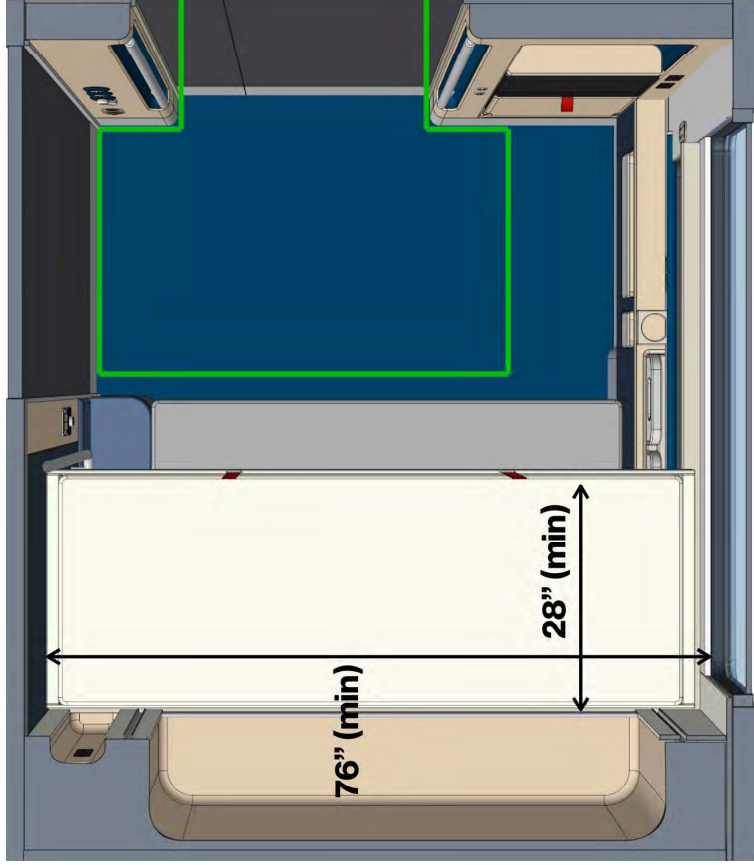



25-F-0416 000004272 UNCLASSIFIED 4/2/2016

Accessible Bedroom | Lighting

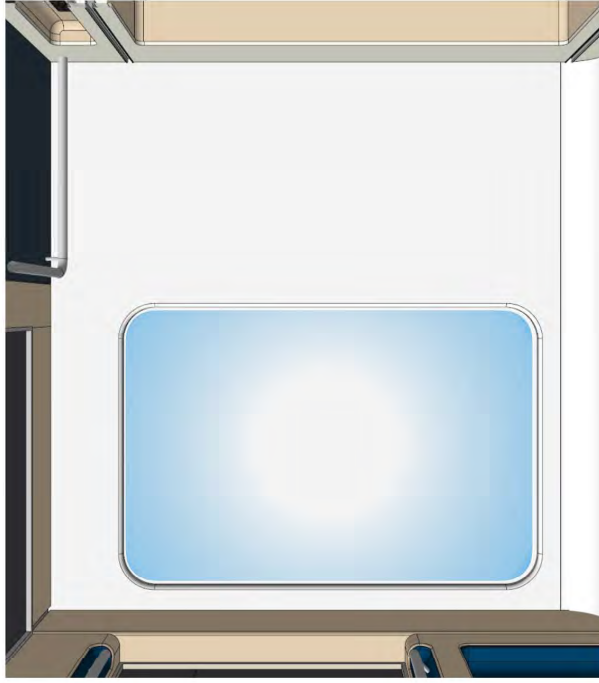
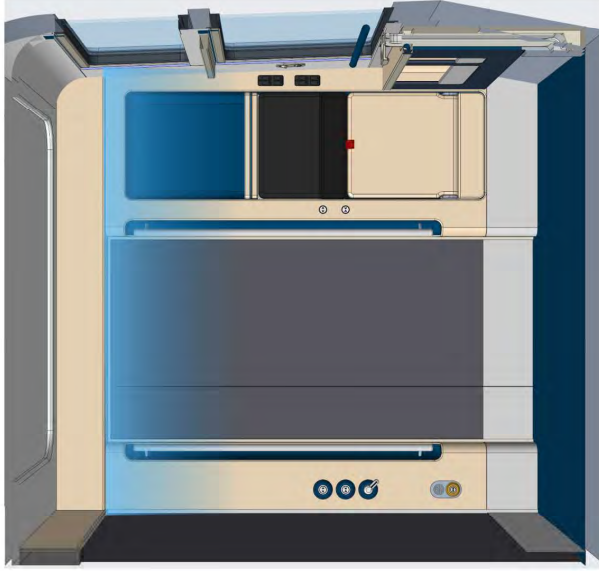

Wall Wash Light

Indirect wash light running down both sides of room.

Ceiling Pool Light

Ring pool lighting in the ceiling provides indirect wash light in the centre of the room.

*See lighting spec for detailed definition.



Under Seat Light

Under seat light should be indirect and spill light out across the floor.



Reading Lights

Reading lights should be provided at each seated location, including the fold out seat. People should be able to adjust the direction and position the light over their lap and in a suitable place to read a book at night. Switches should be located near or on the light.

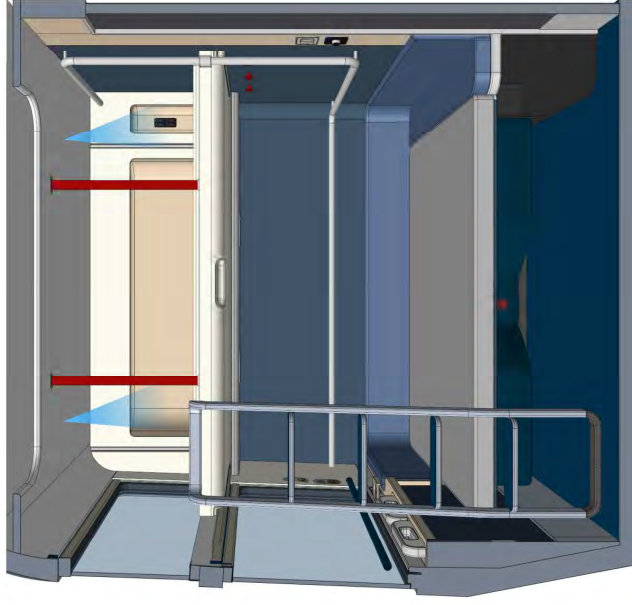

Bunk Reading Light

Reading lights should be provided, embedded in the ceiling above the bunk. Two lights in total located at each end of the bed. Light switches should be located next to the reading light.

*See lighting spec for detailed definition.



25-F01-0415 000004272 UNCLASSIFIED 4/20/24

Accessible Bedroom Toilet | Accessibility

Accessible Bedroom Toilet | Accessibility

24-FD-10416 000004272 "UNCLASSIFIED" 4/20/2016

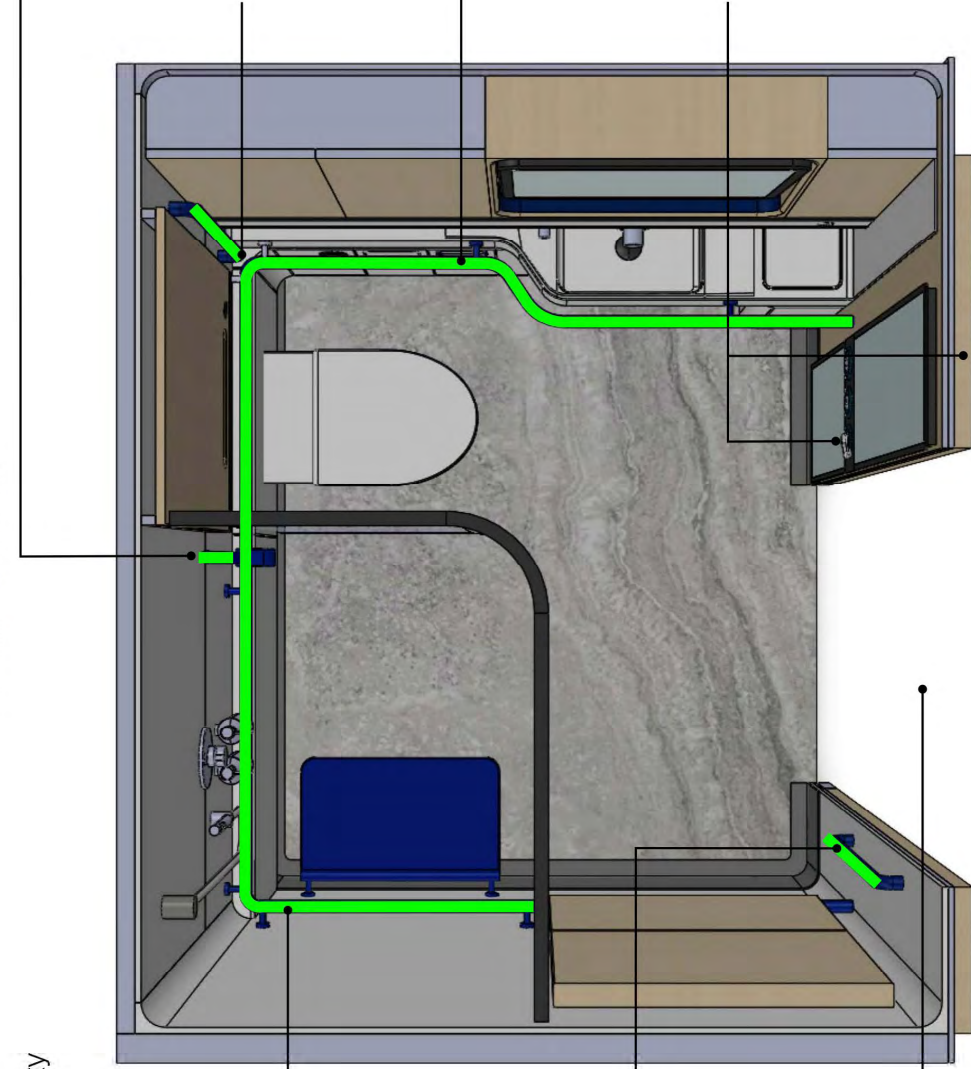

Shower Handrail
ADA compliant horizontal handrails positioned in the shower area. The handrail should be a compliant height and length.

Vertical Handrail 1
ADA compliant vertical handrails positioned adjacent to the bathroom door. It can also be used by baby changing table.

36" Toilet Door
The toilet door should be an automatic sliding door, this can be achieved with two leaves. The door is positioned to create space for a T maneuver when the door is open and the bed is deployed.

Fold Down Handrail

The fold down handrail can be used to aid transfer on to the shower seat and on to the toilet. When stored in the vertical position it should not protrude from the sidewall more than 3" to keep side transfer space clear for the toilet.

Vertical Handrail 2

ADA compliant vertical handrails positioned in front of the toilet.

Toilet + Sink Handrail

ADA compliant horizontal handrails positioned in the toilet and sink area. The handrail should be a compliant height and length. The handrails should be one continuous loop where possible.

Toilet Door Controls

The controls for the bathroom door must be ADA compliant in position, size and configuration. The buttons should be easy and intuitive to use. An accessible manual lock should be included with an indicator to show lock condition. The buttons should have visual and haptic feedback.

Accessible Bedroom Toilet | Accessibility

25-FD-10416 0000004272 "UNCLASSIFIED" 4/20/2016

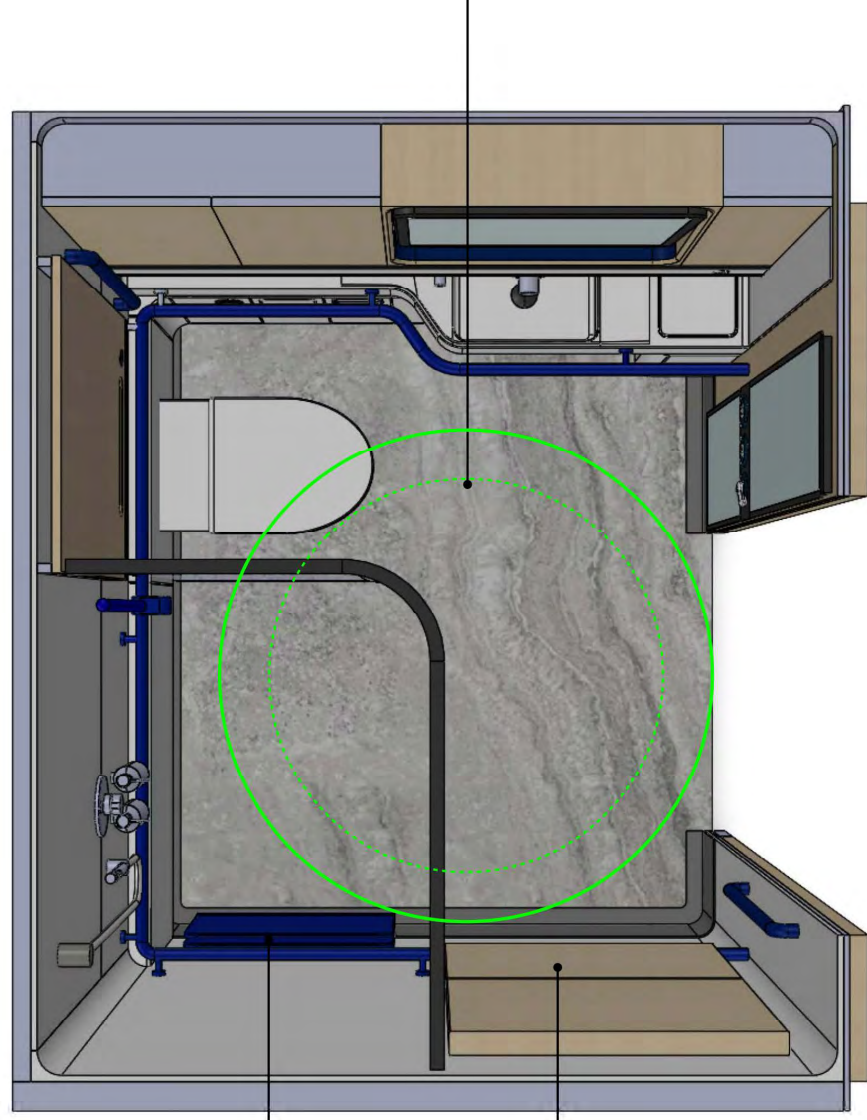

Shower Seat
Shower seat when folded up should be clear of the 60" turning circle.

Baby Changing Table
Baby changing table when stored should clear of the 60" turning circle.

60" Turning Circle
A turning circle should be provided in the Toilet when the door is closed. It is acceptable that a portion of the turning circle at four height can be overlapped in compliance with ADA guidelines.

Accessible Bedroom Toilet | Accessibility

26-FD-00416 0000004272 "UNCLASSIFIED" 4/20/2016

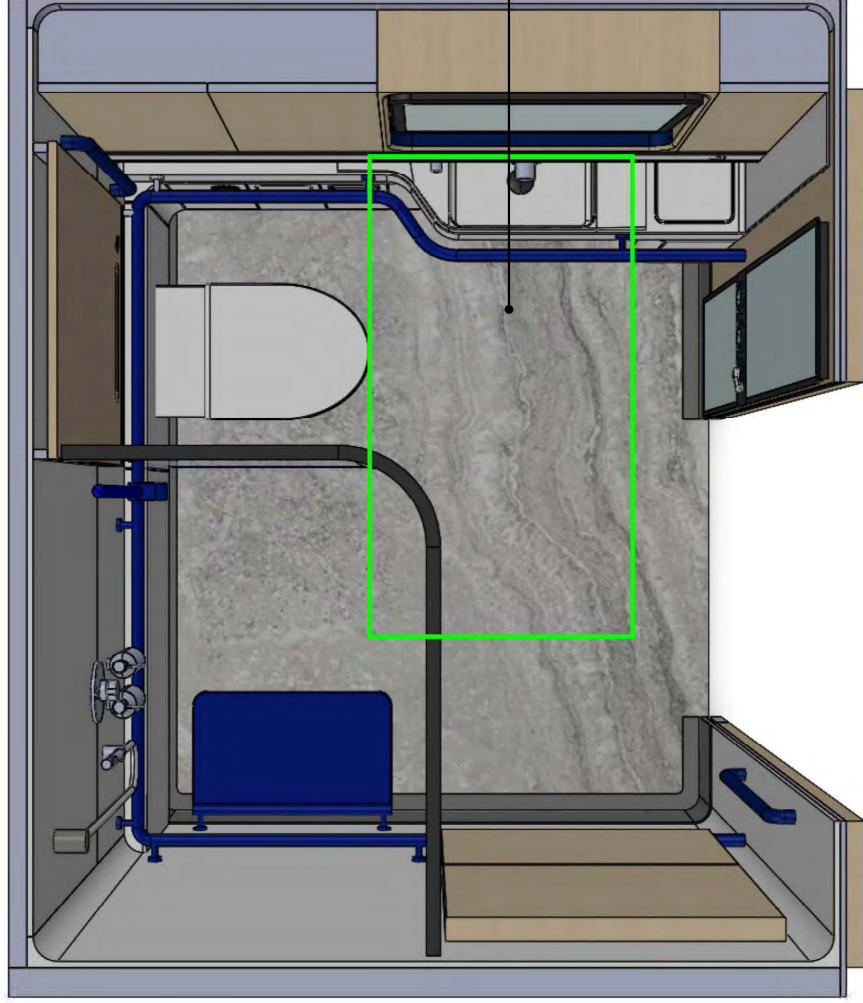

RVAAAC Accessible Space 1

There should be clearance directly in front of the sink and vanity unit for an RVAAAC accessible space of 59" x 32". The sink overhang should comply with ADA and RVAAAC guidance. Dimensions and usability will be subject to mock-up testing and Amtrak approval.

Accessible Bedroom Toilet | Accessibility

25-FD-00416 0000004272 "UNCLASSIFIED" 4/20/2016

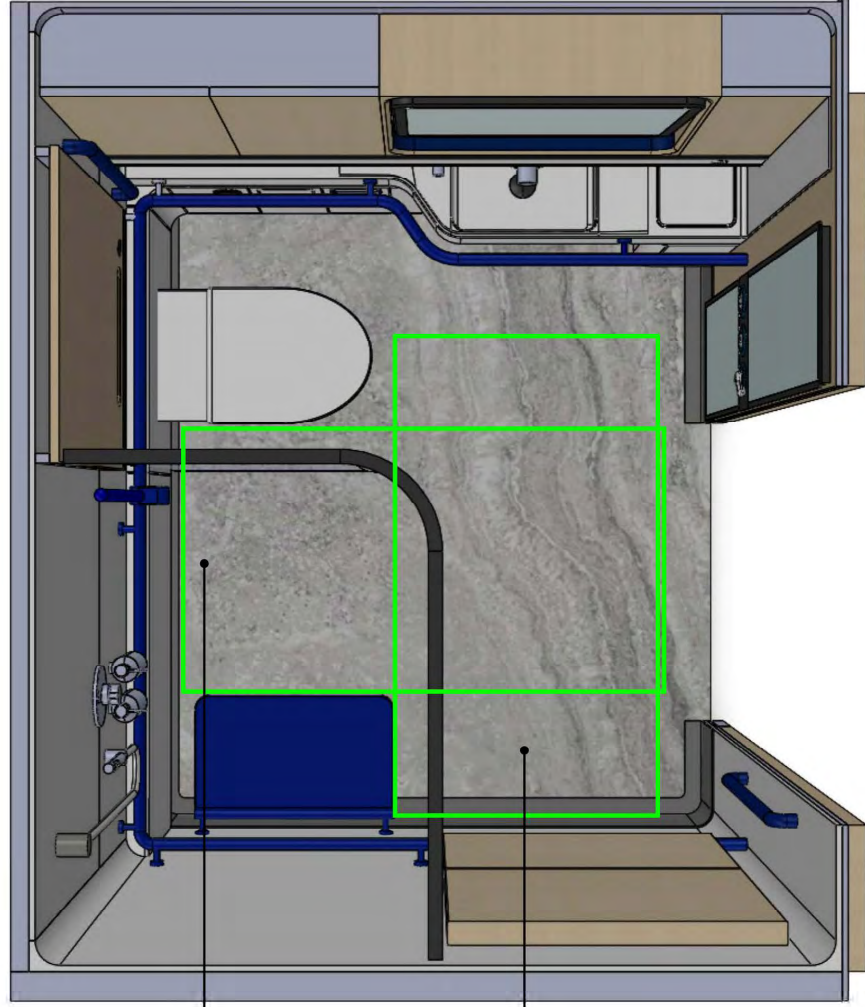

RVAC Accessible Space 2

There should be clearance between the toilet and shower seat when folded down for an RVAC accessible space of 59" x 32". This position should be suitable for side transfer to the toilet and the shower seat.

RVAC Accessible Space 3

There should be clearance between the shower seat when folded down and the door sidewall for an RVAC accessible space of 59" x 32". This position should be suitable for side transfer the shower seats and access for the baby changer.

Accessible Bedroom Toilet | Accessibility

25-FD-00416 0000004272 "UNCLASSIFIED" 4/20/2016

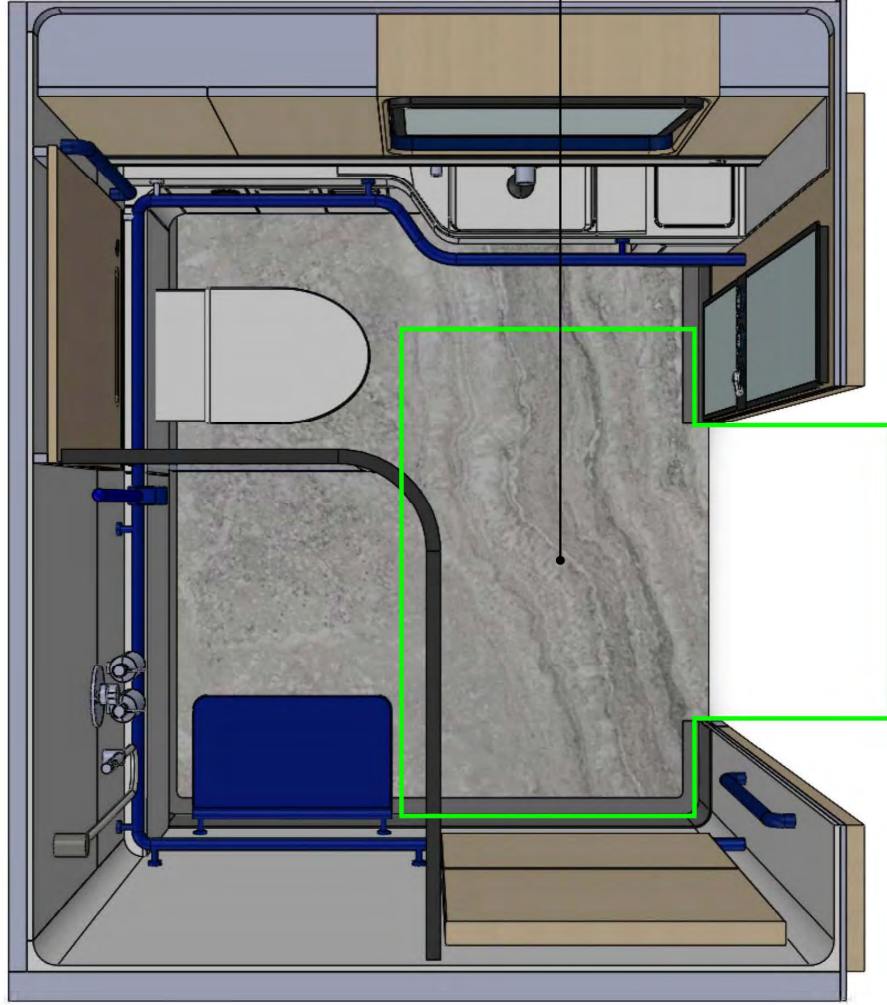

ADA T- maneuver Space

When the shower seat is folded down, there should be clearance for a T- maneuver through the bathroom door.



25-F010415 000004272 UNCLASSIFIED 4/20/24

Accessible Bedroom Toilet | Room Features

Accessible Bedroom Toilet | Amenities and Features

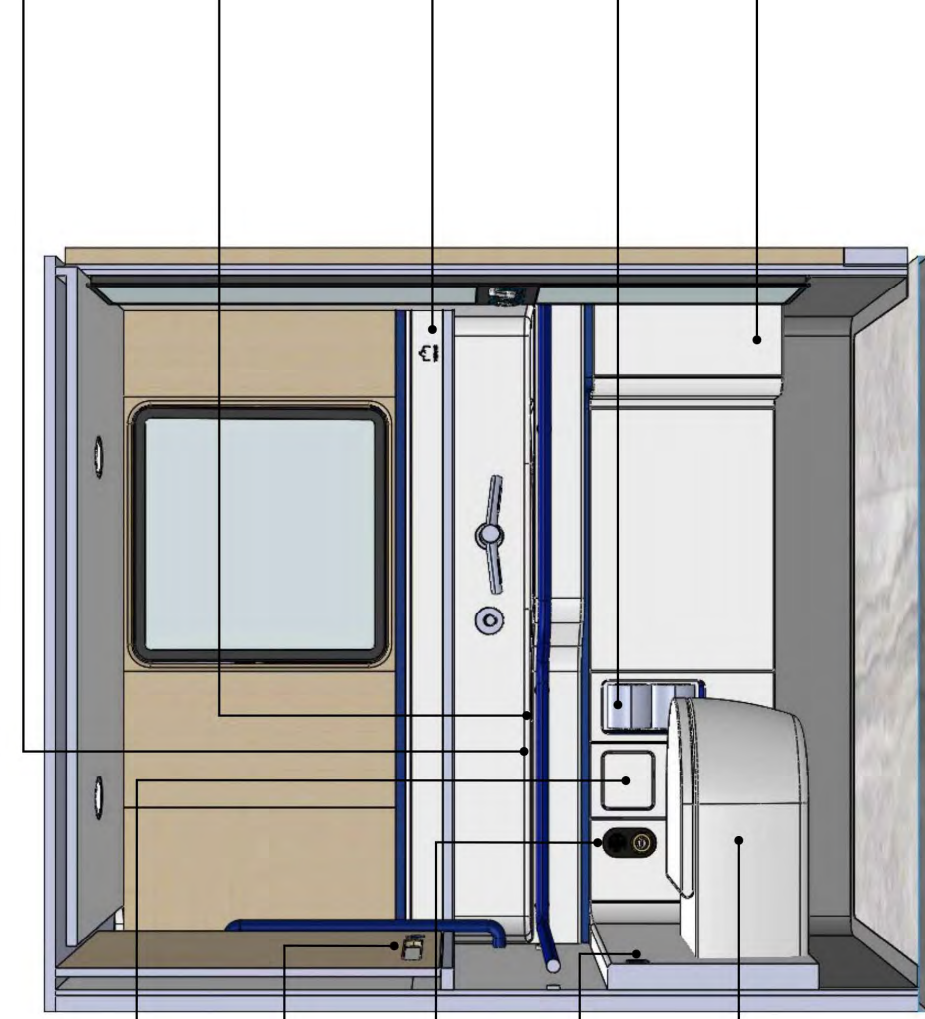

Sanitary Waste

A sanitary bin with modesty flap is provided to the right of the toilet. Position and function should comply with ADA.

Toilet Seat Cover Dispenser

A dispenser for paper toilet seat covers should be located by the toilet. Position and function should comply with ADA regulations.

Call for Aid Button

There should be a call for aid button adjacent to the toilet. Position and function should comply with ADA.

Toilet Flush

A two button touch-less flush is located on the back wall providing standard and eco flush. Position and function should comply with ADA.

Toilet

The toilet has a seat and a cover. The form of the toilet is undercut at the bottom to maximize wheelchair clearance. Toilet seat and seat lid should all have soft close mechanisms.

Sharps Bin

Provision for a sharps bin should be provided within the room.

Sink Surface

Sink surface should be large enough to store a wash bag and toiletry items and aid the safe and clean disposal of a colostomy bag. Marine edge should run along entire length and a draining surface angled towards sink.

Tissue Dispenser

Tissue dispenser should be positioned near the trash and sink.

Toilet Paper Storage

The toilet paper should be stored in the wall of the bathroom.

Trash

A trash bin is provided to the right of the sink. The volume should be 14-gallons minimum. Position and function should comply with ADA. The opening to the trash should be a minimum of 8" x 10".

Accessible Bedroom Toilet | Amenities and Features

Crew Cabinet
Cabinet storage is provided for crew to store cleaning and bathroom servicing items.

Automatic Water Faucet
Water is automatically dispensed when hands are placed under the faucet. A physical element should be visible so it is clear where water is dispensed from. Temperature of water should be controllable. Water pressure, water flow should not create any water splash or spill outside of the sink area.

Automatic Hand Drier
An automatically triggered hand dryer should be included under the vanity unit. This can be part of the faucet or supplied separately. A physical element should be visible so it is clear how to use the dryer. The dryer should use high velocity air and HEPA filters similar to a Dyson Airblade. The air dryer should not blow water out of the sink.

Soap Dispenser
An automatic soap dispenser should be included above the sink area. A physical element should be present to indicate how and where the soap will dispense.

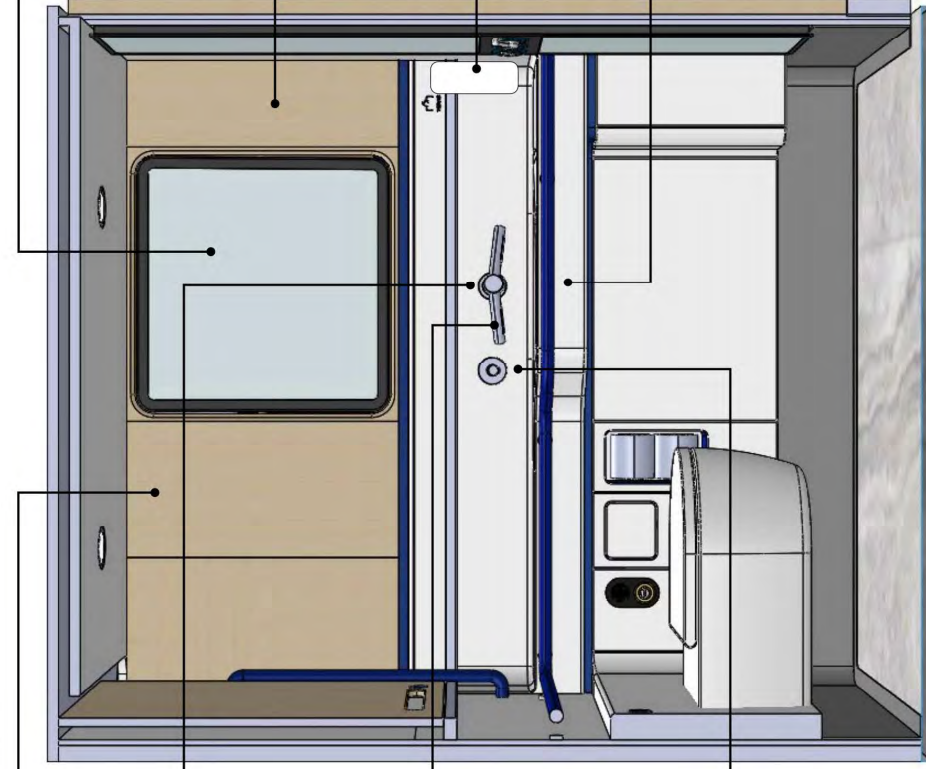

Vanity Mirror
A large mirror is positioned in front of the sink. The bottom edge of the reflective surface should be a maximum of 40" above the finish floor. If this is not possible, the mirror should be angled to allow wheelchair passengers to use it.

Passenger Cabinet
A cabinet to the right of the mirror should be provided for passengers to store personal toiletry items. The position of the lower portion of this cabinet should comply with ADA reach rules.

Hand Lotion Bottle
An area on the side of the sink should be reserved for a refillable hand lotion bottle fixed to the side wall.

Sink
The sink should have a marble edge so any water spill is captured in the sink area. A splash back behind the sink should protect the surrounding areas from water splashed onto the back wall from the sink area. The sink should be accessible while sat on the toilet.

Accessible Bedroom Toilet | Amenities and Features

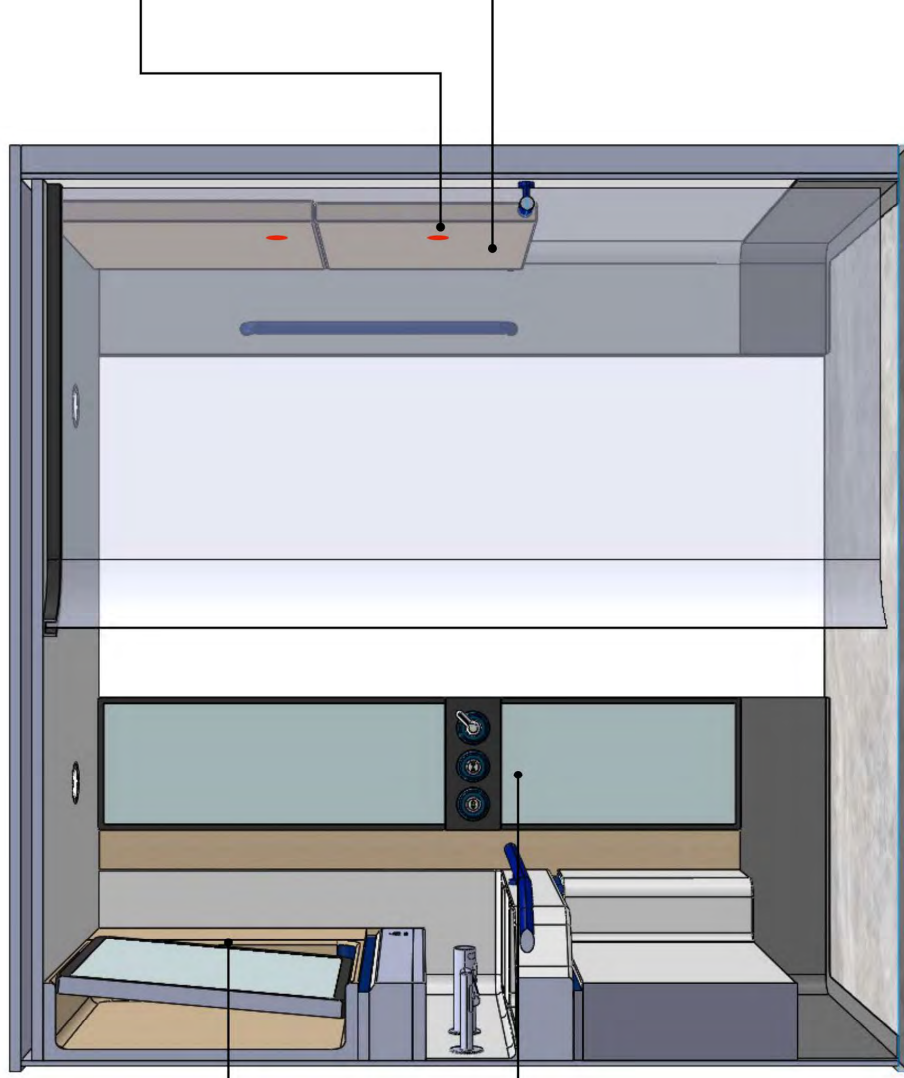

Towel Storage

A cabinet, surface or hooks should be provided to store bath towels, face cloths and hand towels (2 of each standard Amtrak towels). These should be located in a position accessible for a person using a wheelchair

Towel Hooks

At least two towel hooks should be provided. One hook must be within the reach range of a person using a wheelchair at a maximum height of 45".

Full Length Mirror

A full length mirror should be provided in addition to the sink mirror. The bottom edge of the reflective surface should be a maximum of 40" above the finish floor.

Fold Down Baby Changing

A baby changing table should be provided with an RVAC compliant clear space in front of it. The changing table should be easy to deploy and stow with an intuitive handle. The mechanism should be durable free from jamming and racking. The design should meet abuse loads. It should have a soft opening mechanism. Position and function should comply with ADA.

Accessible Bedroom Toilet | Amenities and Features

25-FD-00416 0000004272 "UNCLASSIFIED" 4/20/2016

Drainage

The floor in the shower area should be designed to minimize water spreading to other parts of the room with a drainage angle directing water towards a covered drain in the corner of the room. The floor must also allow wheelchair passengers complete freedom to turn and maneuver in the room with floor levels compliant with ADA regulations.



Accessible Bedroom Toilet | Amenities and Features

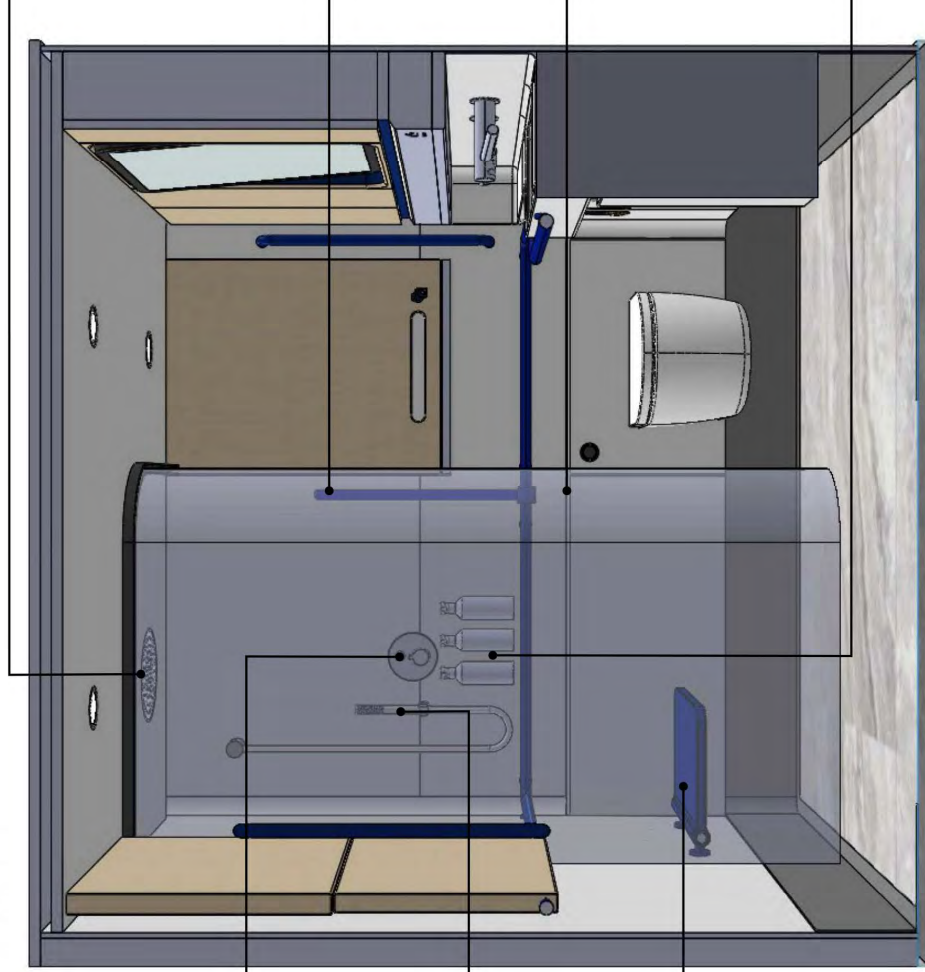

Rain Shower

A rain shower in the ceiling provides a shower above head height. Rain shower should be seamlessly integrated into the ceiling in order to maximize head room in the bathroom.

Fold Down Grab

The fold down handrail should be provided to aid transfer on to the shower seat and on to the toilet seat. When stored in the vertical position it should not protrude from the sidewall more than 3" to keep side transfer space clear for the toilet. Dimensions, position and function should comply with ADA.

Shower Curtain

A shower curtain should be provided to control water spread in the room while the shower is on. It should also provide a modesty screen for users. The curtain should be easy to deploy and stow with an intuitive handle.

Dispensing Bottles

3 refillable Amtrak bottles dispensing shampoo, conditioner and body lotion. Bottles should be fixed to the wall and easily refilled or replaced by Amtrak staff. Dimensions, position and function should comply with ADA.

Shower Control

An on/off button and temperature control are located on the bathroom wall close to the door. The shower control should prevent any accidental activation when using the toilet. Dimensions, position and function should comply with ADA.

Hand Shower

A second hand shower is located with a slimline design handset. A hose clip should be included to prevent the hose from rattling while the train is in transit. Dimensions, position and function should comply with ADA.

Shower Seat

A fold down shower seat should be provided. Dimensions, position and function should comply with ADA.



25-FOI-0416 000004272 UNCLASSIFIED 4/2/24

Accessible Bedroom Toilet | Lighting

Accessible Bedroom Toilet | Lighting

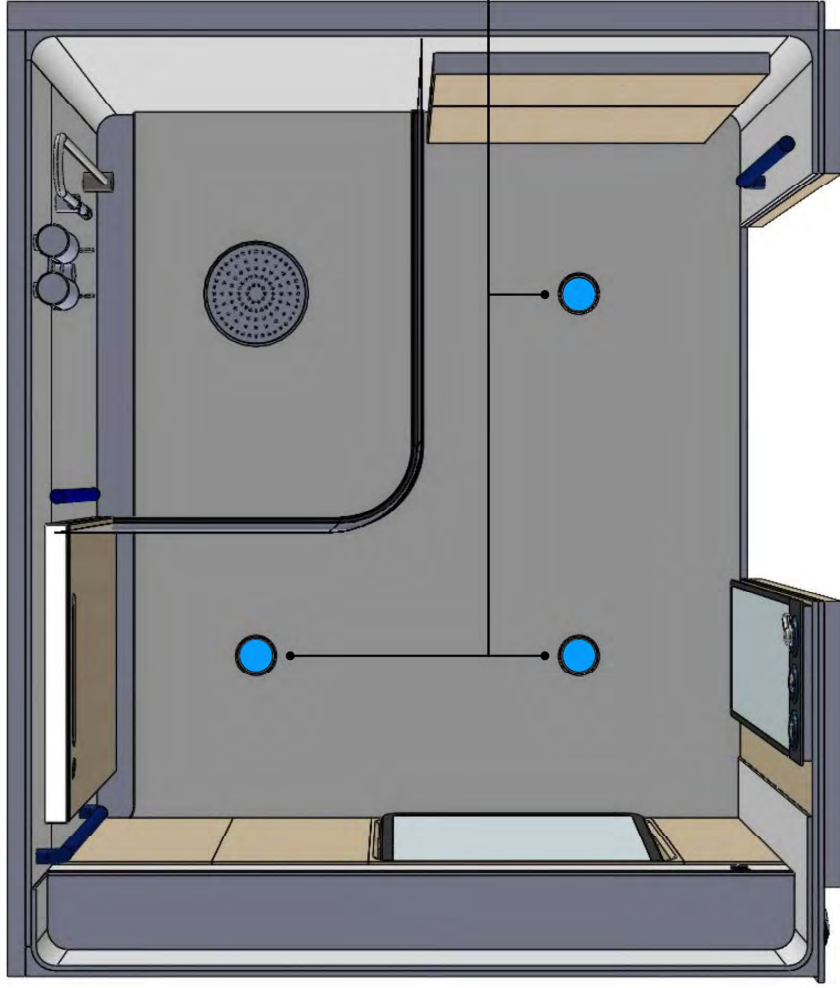

LED light panel spot

Small circular LED light panels act as spot lights - frame to be color matched. Activated only when door is locked from the inside. Position, number and style to be approved by Amtrak.

Accessible Bedroom Toilet | Lighting

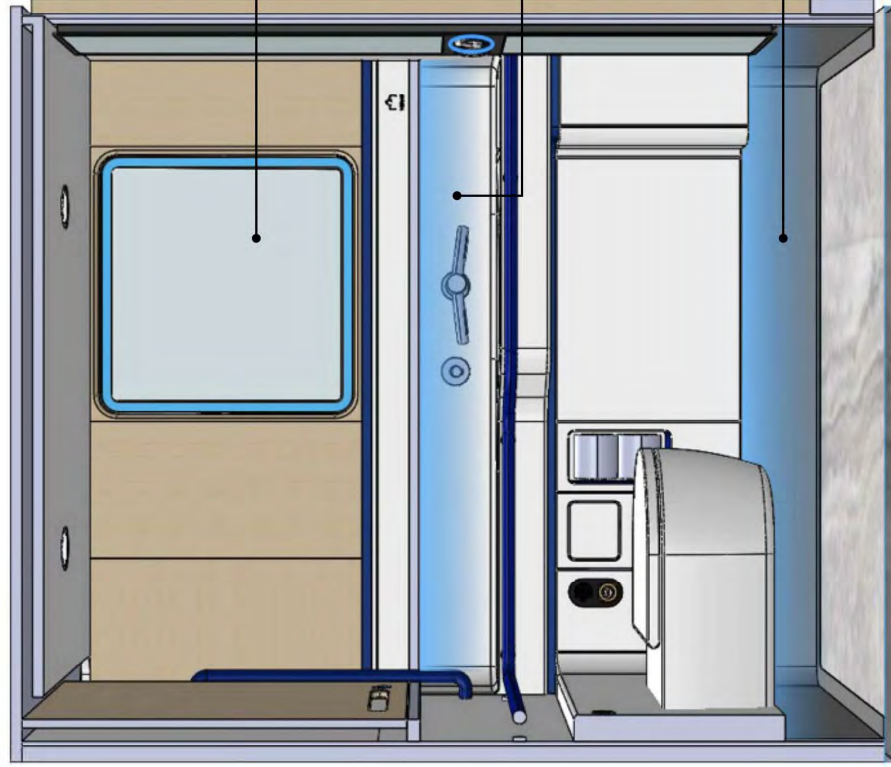

LED Illuminated Mirror

The vanity mirror is illuminated with an LED strip around the border. Activated with a switch located near or on the mirror.

Vanity Wash Light

The cabinet washes indirect light on to the sink surface. Activated only when door is locked from the inside.

Floor Wash Light

Lower sidewall panels wash indirect light on to the floor. Activated by the master control switch.



REPORTS 800.872.7273 "UNCLASIFIED" #2024

- Coach Areas
- Sleeper Bedrooms
- Food & Beverage**
- Toilets & Showers
- Common Use Areas

Amtrak® Long Distance Product Features

Food & Beverage



25-F-01-0415 000000272 "UNCLASSIFIED" 4/2/2014

- Coach Areas
- Sleeper Bedrooms
- Food & Beverage**
- Toilets & Showers
- Common Use Areas
- Crew Areas

Amtrak® Long Distance Product Features

08 | Cafe Counter

Cafe Counter | Features

Display Cabinets

Maximize available space for additional display items menus and Amtrak literature

Digital Menus

Position at point of purchase

Dry Display Area

Premium finishes

Cold Display Fridges

Aisle side and front side

Branding Area

Area reserved for branding

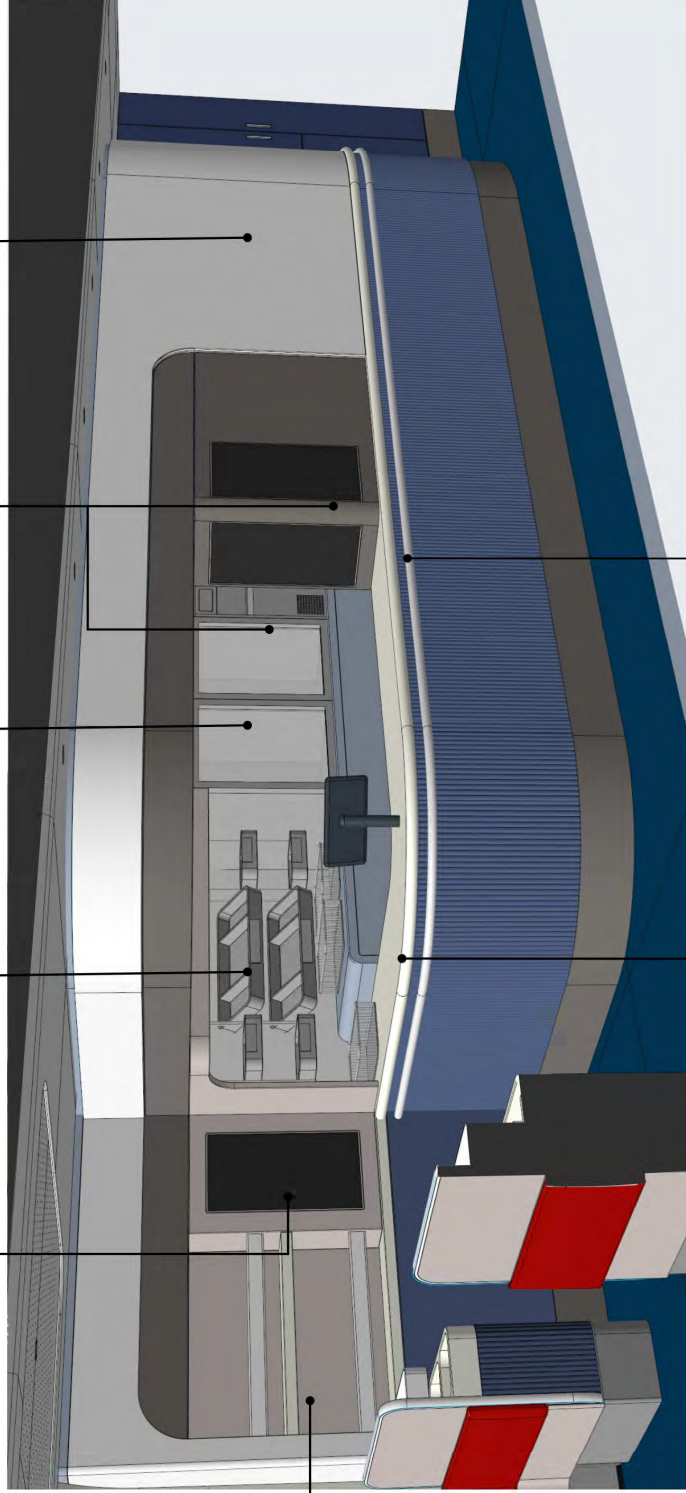

Open Accessible Counter

Accessible counter height over entire length

Handholds

Accessible handhold across entire length of Cafe wall

Cafe Counter | Features

25-F-01-0416 0000004272 "UNCLASSIFIED" 4/20/2016

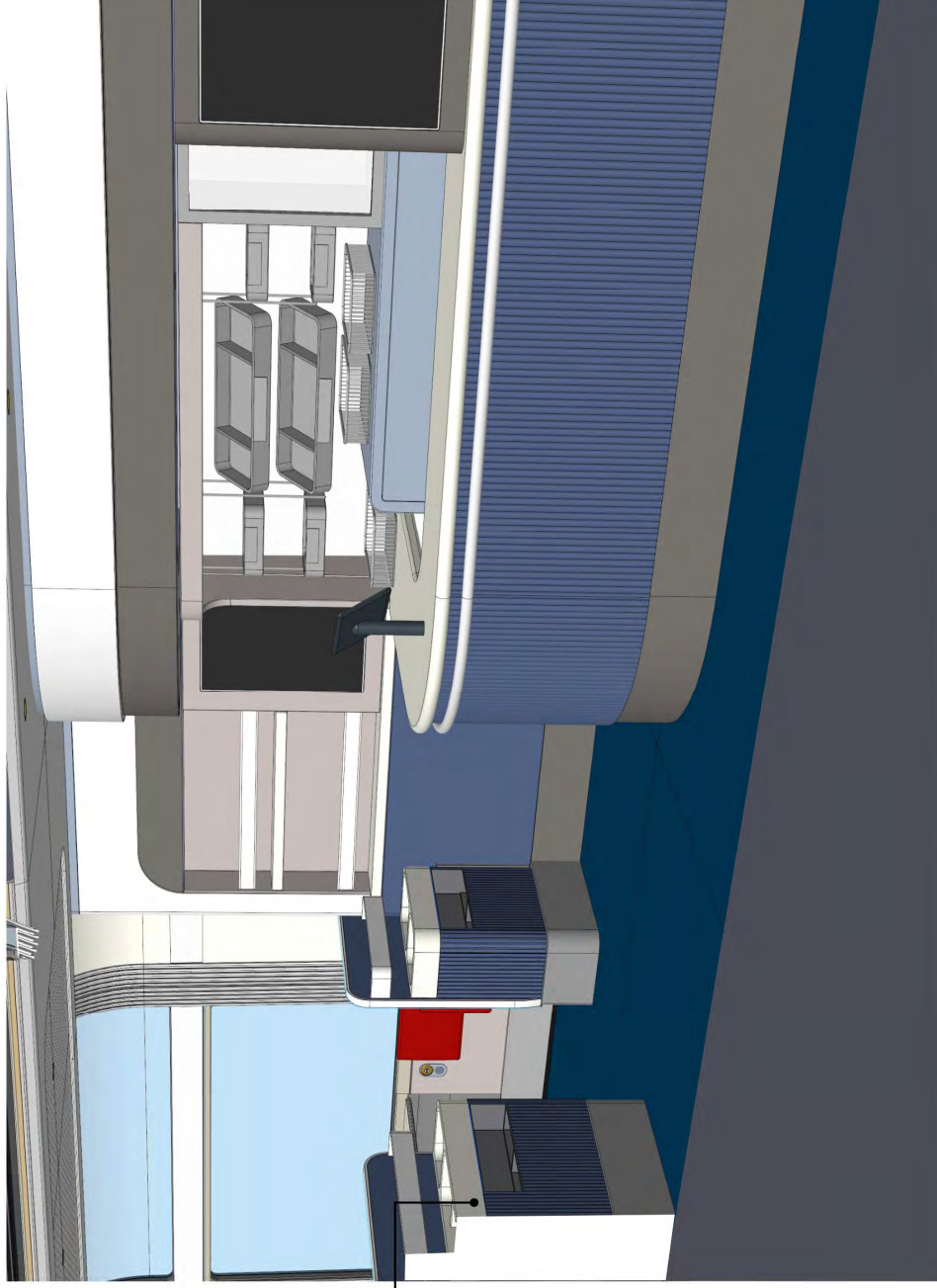

Condiment Stations
Condiment stations to provide space for napkins, condiments and serving items. Shelf to rest a drink or snack. Trash bins maximized in lower area

Cafe Counter | Lighting

25-F-01-0415 000000272 "UNCLASSIFIED" 4/20/2016

Ceiling Wash lights
Ceiling wash lights identical to
with coach areas

Display lighting
Lighting to highlight display
items

Counter spot lights
Down lights to illuminate
counter and counter display

Panel Spot Lights
Spot lights provide downlighting
along aisle and at cafe counter

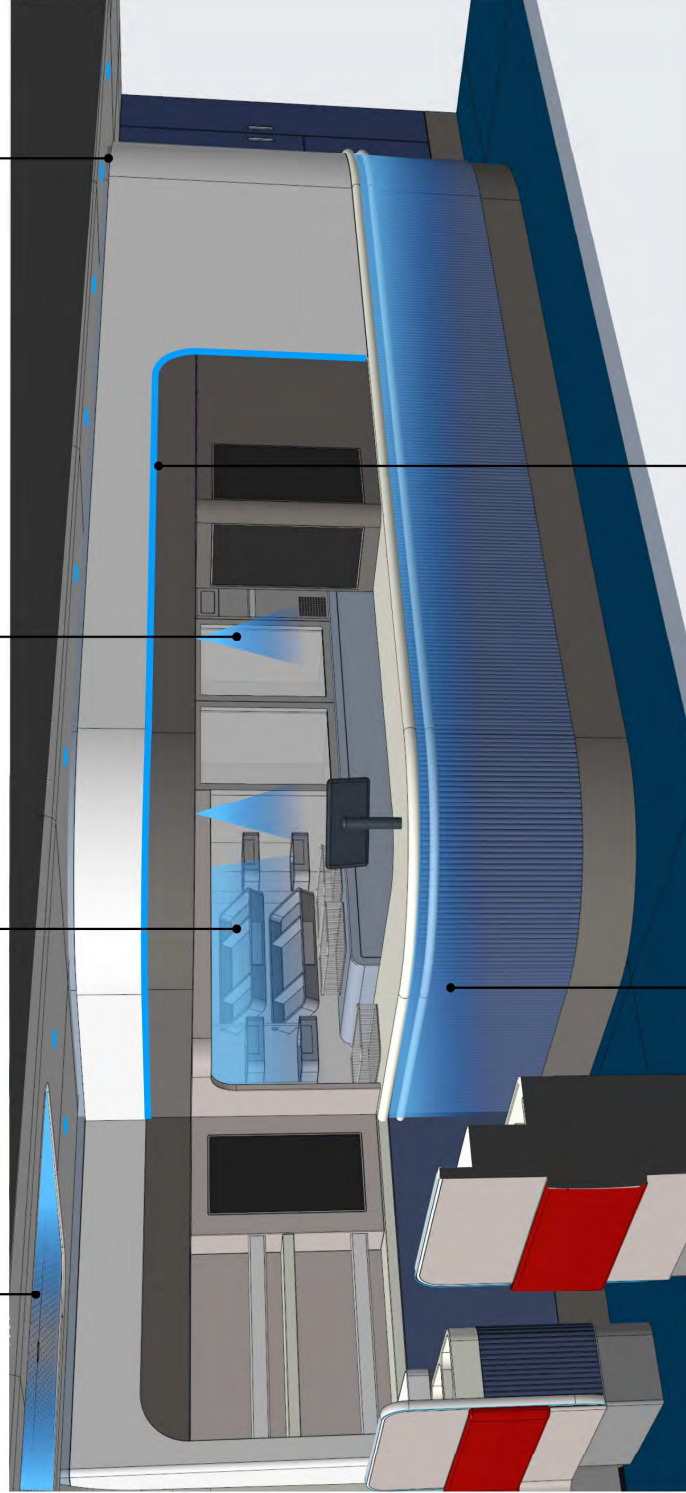

Counter Wash Lights
Indirect light to wash down
entire front edge of the Cafe
counter

Feature Light
Feature or pendant light



3547010416 0000002772 "UNCLASSIFIED" 4/20/2014

Coach Areas
Sleeper Bedrooms
Food & Beverage
Toilets & Showers
Common Use Areas

Amtrak® Long Distance Product Features

09 | Diner & Cafe Features

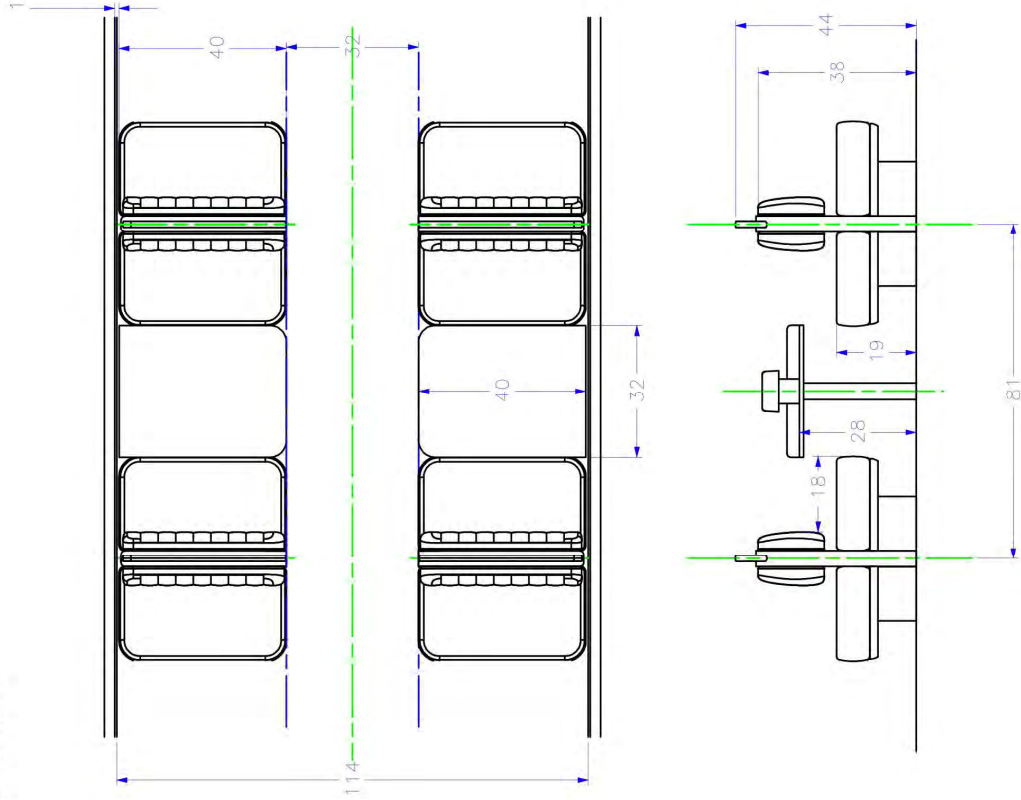

Seat Dimensions

Seat width shall be maximized with a minimum acceptable dimension of 40" wide for a seat suitable for two passengers.

To achieve a 32" accessible path between diner seats, the side wall detail/clearance will need to be minimized and tolerances will need to be tightly controlled. Seat pan height shall be between 18" and 19" with a seat pan depth of no less than 18". Seat back height from finished floor should be a minimum of 38" with a higher divider no lower than 44".

All seat dimensions, cushion density/ shore hardness will be subject to mock-up review, testing and approval by Amtrak.

Table Dimensions

A minimum usable table width of 32" shall be provided. Access in and out of the seats should be evaluated carefully. A tapered leading edge may be required to aid access to the seat. Top of table surface should be between 27" and 28" while also allowing 3" clearances in height for the legs of a 95 percentile male. Table leg location shall be positioned as to not provide a knee clash for passengers.

All table dimensions will be subject to mock-up review, testing and approval by Amtrak.

Window Alignment

The center of the table should be central to the window with the center of the diner module in alignment with the window pillar repeating at an 81" pitch.

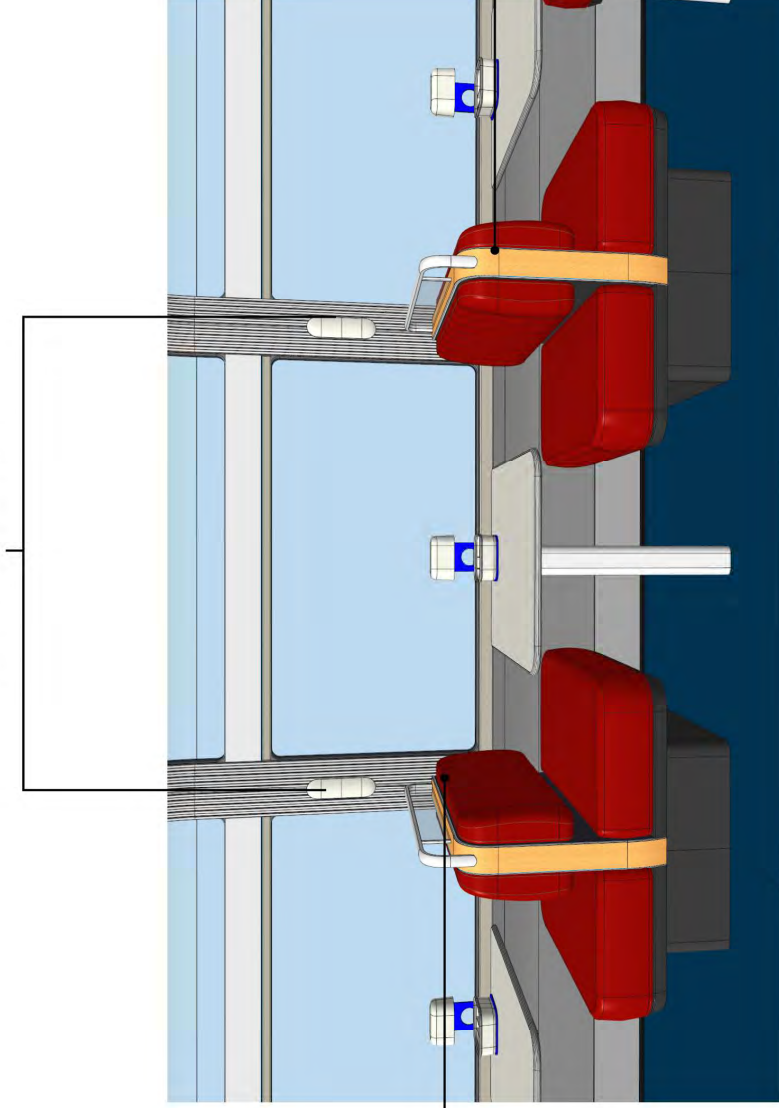

Seat Comfort

Ergonomics, back support, seat back and seat pan pilloing, cushioning and seat trim and detailing will be evaluated and judged carefully during the design review process and will be subject to Amtrak approval.

Seat Stowage

Booth seats should be designed with trunk type stowage in the base. The intention here is to provide extra stowage for crew only access to store emergency supplies. The access and design of the trunk stowage should not negatively impact the comfort of the aesthetic of the seat.

Diner & Cafe | Seating Features

25-FD-10416 0000004272 "UNCLASSIFIED" 4/20/2016

Handholds

Compliant handholds should be provided on the aisle side of every booth seat.

Table Surface

A high quality table surface should have a protective edge trim detail. Split lines should be managed to a high tolerance and sealed to create a flush finish and prevent any potential dirt build up in edges.

Pedestal

Seat pedestals should be seamless with the floor, with no dirt traps or protruding edges to support easy cleaning routines. Pedestals should be undercut from the seat base to provide a floating seat aesthetic.

Table Lamp

A table lamp shall be provided at every table in the Diner against the side wall. An integrated condiment basket or rail shall be provided on the base of the lamp suitable to store a varied arrangement of condiments to be defined during PDR.

Privacy Divider

A glazed privacy divider should be provided between back to back seats. Divider frame should be integrated with the handholds.

Hardwearing Quality

Seat structure should be finished with high quality, hard wearing laminates and veneers. The form of the seats can be simple providing that the design is delivered using premium materials. Laminate edges should be protected with delicate trim details.

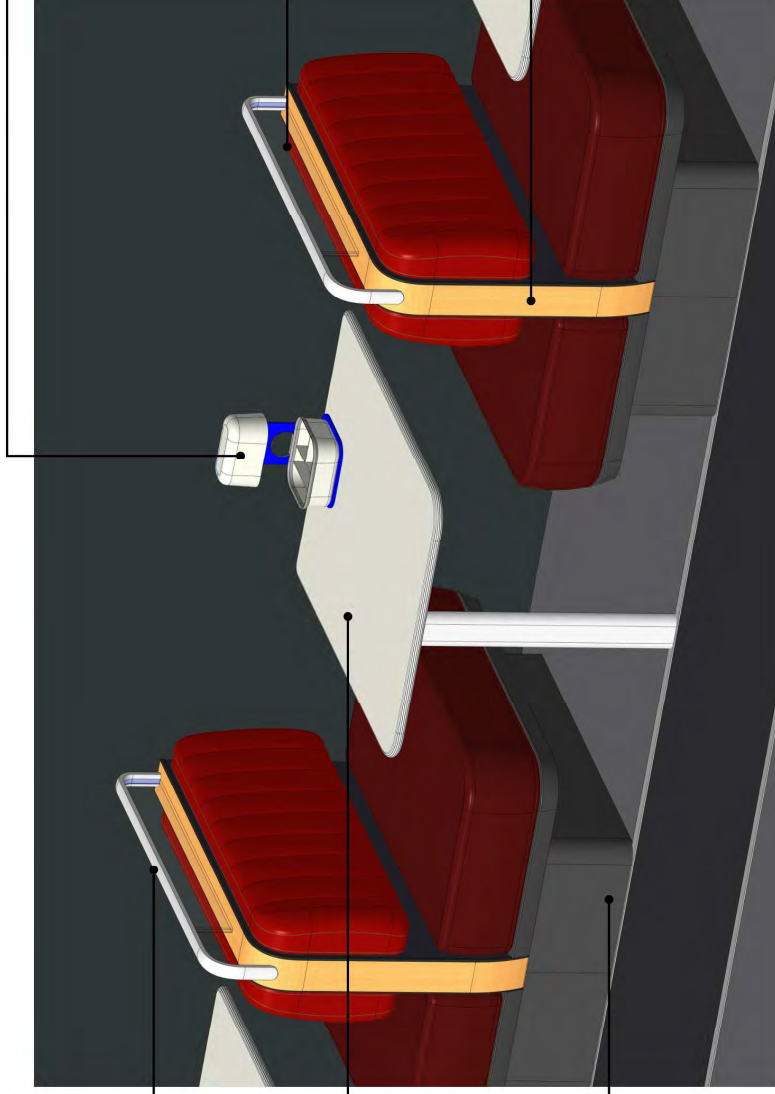
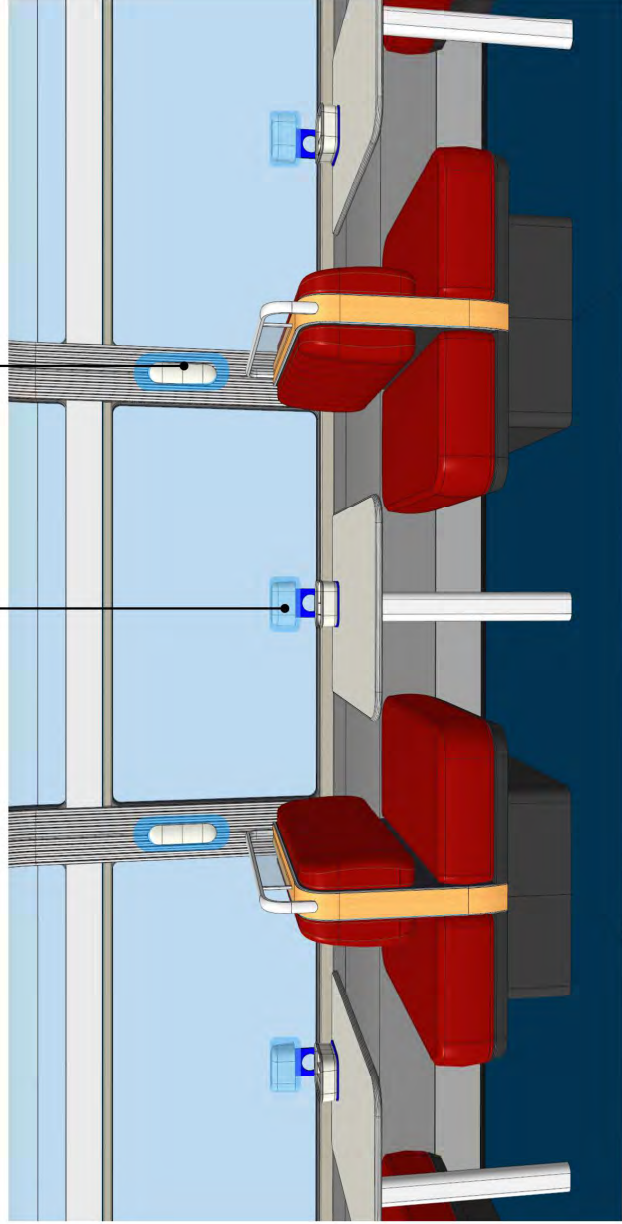

Table Booth Lamp

At each table position in the Diner a table lamp shall be provided. The lamp is intended to be a premium design feature that contributes to the overall lighting levels of the space. .

Wall Lamp

On each window pillar in Cafes, Diner and Lounge areas a wall lamp shall be provided that casts indirect light onto the pillar. The lamp is intended to be a premium design feature that contributes to the overall lighting levels of the space.



Diner | Service Station

25-FD-10416 0000004272 "UNCLASSIFIED" 4/20/2016

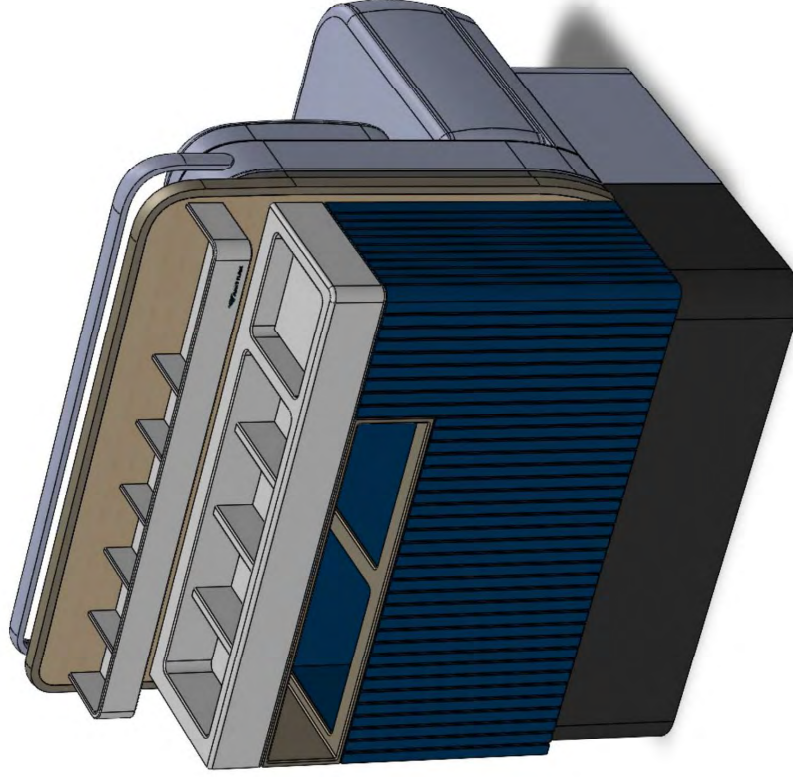

Service Station

A service station should be provided within the Diner. The purpose of this station is to assist crew with performing an efficient food service. Crew will use the station to replenish the tables so should be designed to store provisions needed for table settings including cutlery, napkins (standard and small beverage) menus and items to support coffee service. It should have open storage and closed storage and may also require a trash bin.



35-7010416 000002872 UNCLASIFIED 420204

Coach Areas
Sleeper Bedrooms
Food & Beverage
Toilets & Showers
Common Use Areas

Amtrak® Long Distance Product Features

10 | Lounge Features

Lounge | Features

857010411 000008773 UNCLASSIFIED 4/2024

Beverage Station

A standard beverage station with provisions for coffee, water and trash.

Lounge Coffee Table

Coffee tables should be provided within lounge booths and shall have marine edge milled into the solid surface material.

Lounge Seats

Lounge seats should purposefully differ in style to booth seats and should utilize modular design so that they can be repeated to form both bay and longitudinal seating arrangements.

Lounge Seats

Lounge seats should purposefully differ in style to booth seats and should utilize modular design so that they can be repeated to form both bay and longitudinal seating arrangements.

Lounge Side Tables

Any longitudinal arrangements of lounge seats shall provide small integrated side tables - side tables should have marine edges built into the top surface or created using a trim edge.

Power Outlets

Power sockets and USB ports should be distributed around the seating so there is at least one socket and one USB port per seat.

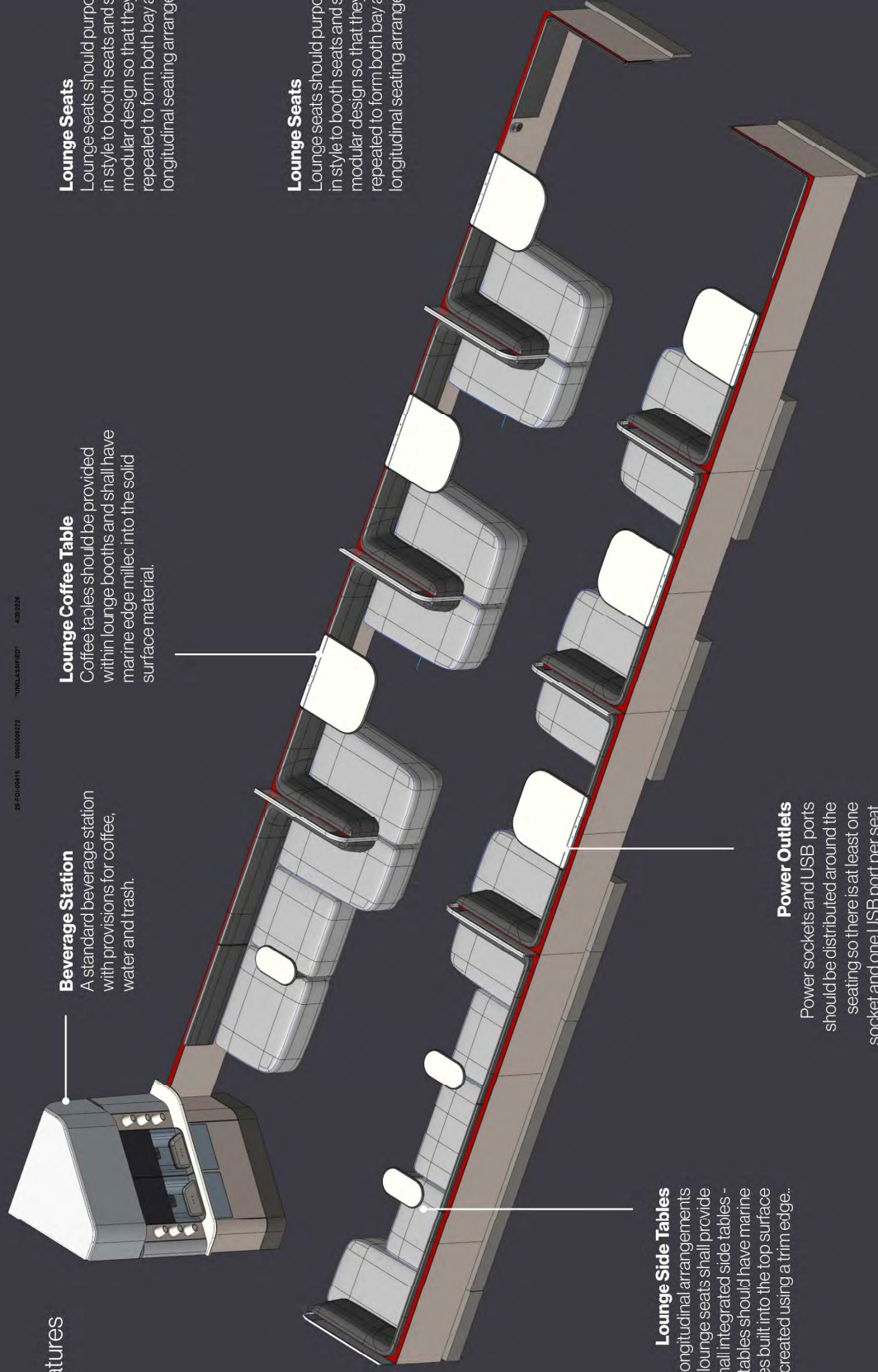

Lounge | Features

26-FDI-0416 000004272 "UNCLASSIFIED" 4/20/2016

Seating Dimensions
Lounge seats should have a minimum seat pan depth of 20" and a minimum seat width of 20". Seat pan height should be a minimum of 18".

Seat Comfort
Ergonomics, back support, seat back and seat pan pillowing, cushioning and seat trim and detailing will be evaluated and judged carefully during the design review process and will be subject to Amtrak approval.



Lounge Privacy Dividers
Privacy dividers should be included where seating is back-to-back. The height of the divider shall be low enough not to obstruct view out of the windows, yet high enough to provide some level of privacy for seated passengers.

Grab Handles
Purposeful and compliant handholds integrated with the divider should be located on entry and exit points to lounge booths.



REPORTS FORMS UNCLEBIRD #2024

- Coach Areas
- Sleeper Bedrooms
- Food & Beverage
- Toilets & Showers**
- Common Use Areas

Amtrak® Long Distance Product Features

Toilets & Showers



3547010416 0000002772 "UNCLASSIFIED" 4/20/24

Coach Areas
Sleeper Bedrooms
Food & Beverage
Toilets & Showers
Common Use Areas

Amtrak® Long Distance Product Features

11 | Accessible Toilet Room

ATR | General

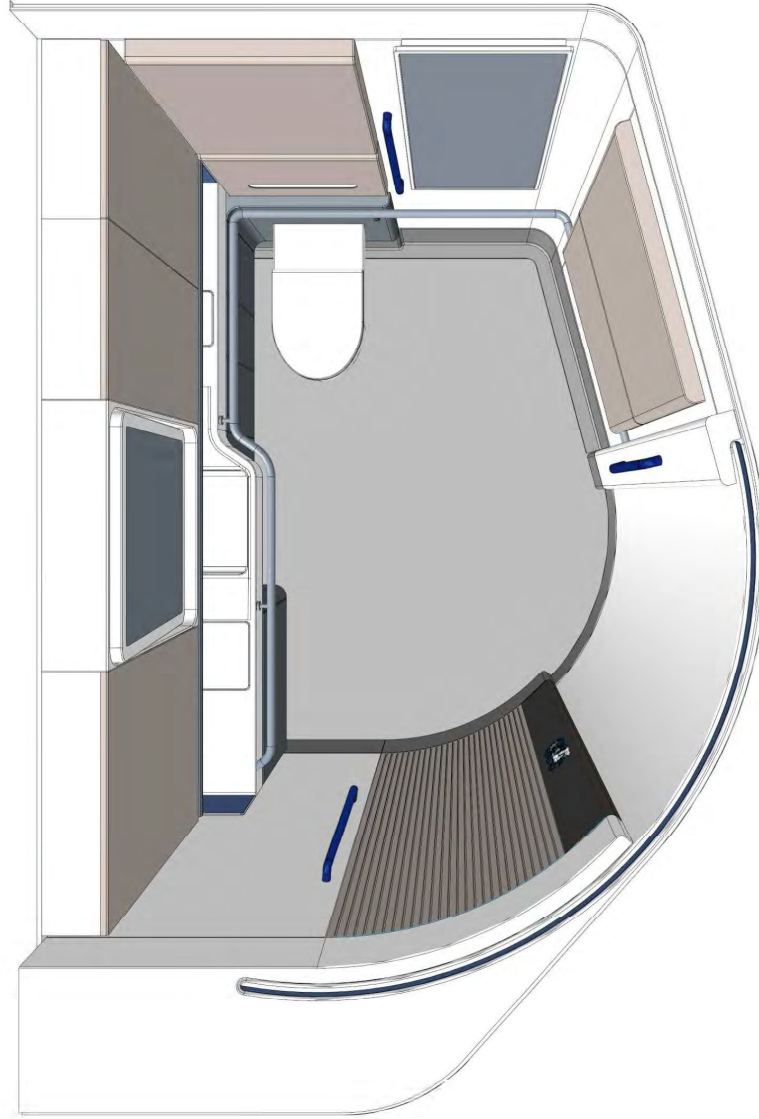

The Accessible Toilet Room

The ATR is ADA compliant but also taking on the RVAAC enhanced accessibility recommendations for restrooms.

Design will be subject to mockup, user testing and Amtrak approval.

ATR | Amenities and Features

25-FD-0416 000004272 "UNCLASSIFIED" 4/20/2016

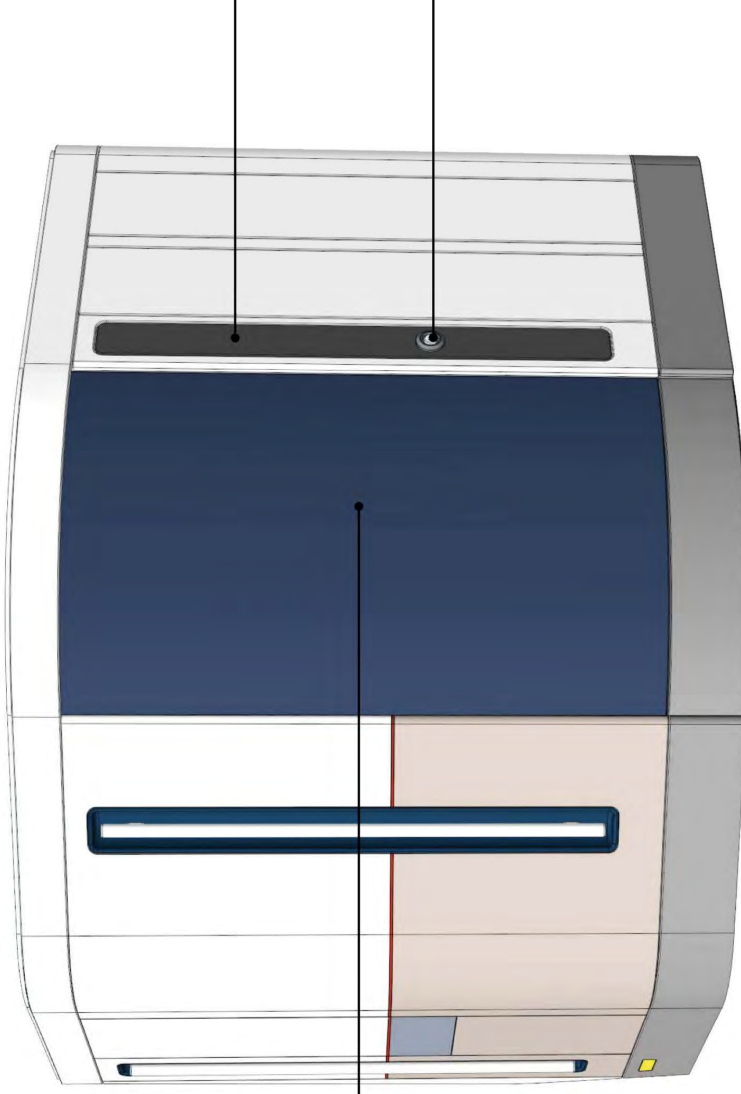

Occupied Light

A clear signal to show if the toilet is occupied/available or out of service should be provided.

Room Door Controls

The controls for the bathroom door must be ADA compliant in position, size and configuration. The buttons should be easy and intuitive to use. The buttons should have visual and haptic feedback for occupied, out of service and available.

Branding and Information Panel

A space should be reserved for signage and branding.



25-F-00416 000004272

"UNCLASSIFIED"

4/2/2016

ATR | Accessibility

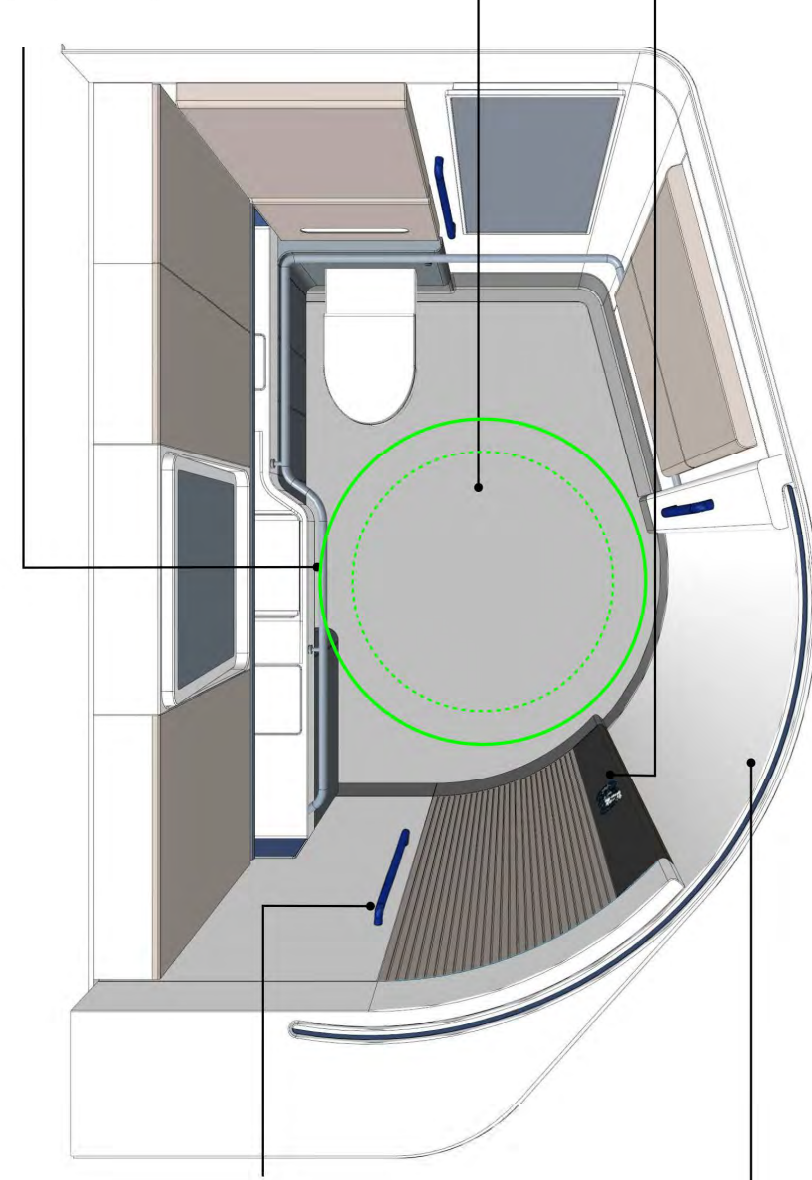

Toilet + Sink Handrail

ADA compliant horizontal handrails positioned in the toilet and sink area. The handrail should be a compliant height and length. The handrails should be one continuous loop where possible.

Vertical Handrails

ADA compliant vertical handrails shall be provided and will be subject to review during mockup stages.

60" Turning Circle

A 60" turning circle should be provided inside the toilet with the door closed.

Room Door Controls

The controls for the bathroom door must be ADA compliant in position, size and configuration. The buttons should be easy and intuitive to use. An accessible manual lock should be included with an indicator to show lock condition. The buttons should have visual and haptic feedback.

44" Toilet Door

The toilet door should be an automatic sliding door and should have a minimum clear opening of 44".

***The position of all accessible interaction points, turning spaces and clearances will be subject to review, mockups, and user testing.**

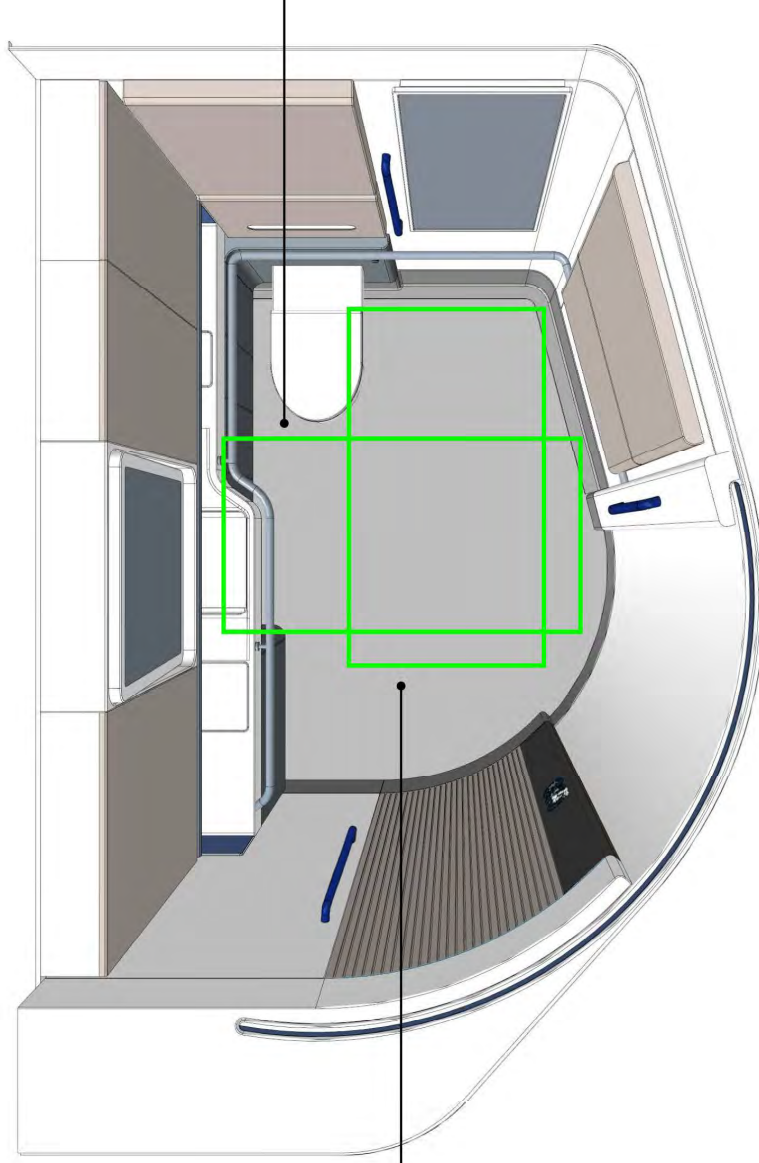

RVAAC Accessible Space 1
There should be clearance directly in front of the sink to fit an RVAAC accessible space of 59" x 32". Access to the sink should comply with ADA and RVAAC clearances.

RVAAC Accessible Space 2
There should be clearance adjacent to the toilet for an RVAAC accessible space of 59" x 32". Space should be in a suitable place to aid transfer to the toilet.

***The position of all accessible interaction points, turning spaces and clearances will be subject to review, mockups, and user testing.**

ATR | Amenities and Features

24-FD-10416 000000272 "UNCLASSIFIED" 4/20/2016

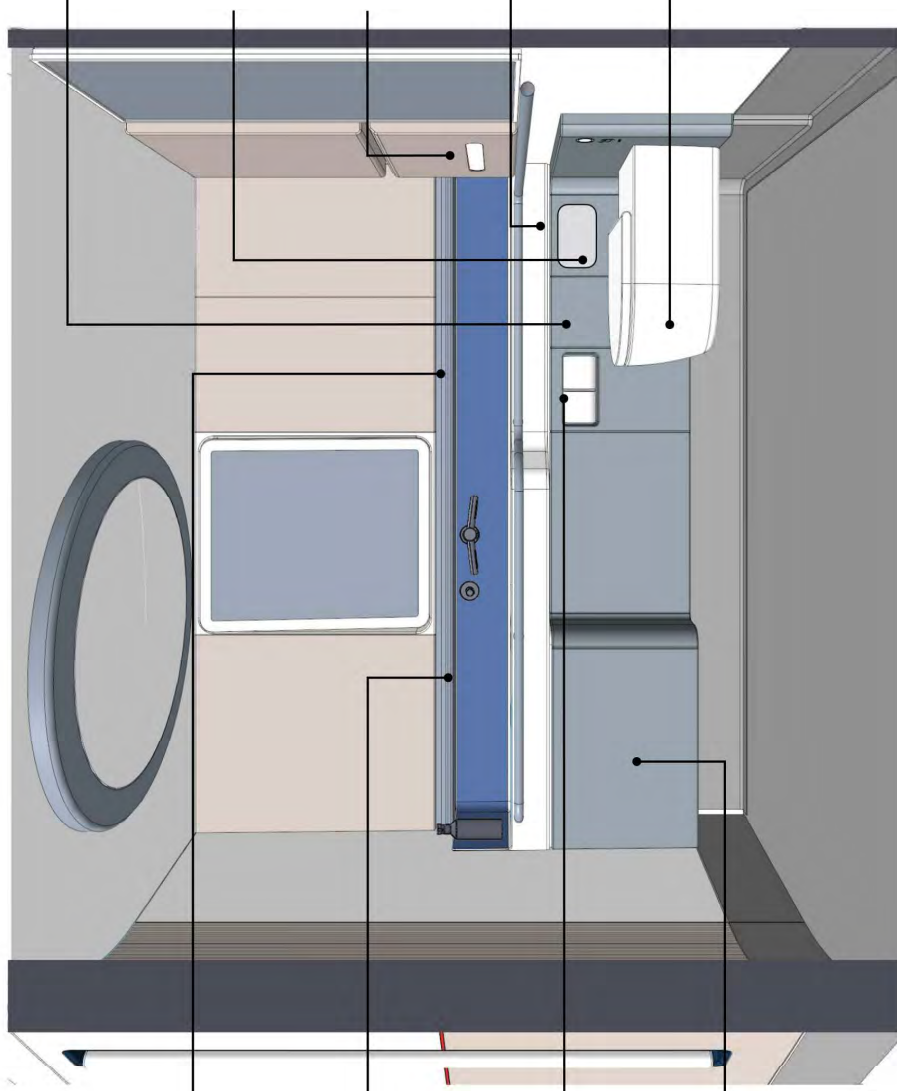

Paper Tissue Dispenser

A paper tissue dispenser should be positioned near the trash and sink. Position and function should comply with ADA.

Paper Towel Dispenser

A paper towel dispenser should be positioned near the trash and sink. Position and function should comply with ADA.

Toilet Paper Storage

The toilet paper should be stored in the wall of the bathroom. Position and function should comply with ADA.

Trash

A trash bin is provided to the right of the sink. The volume should be 16 gallons minimum. Position and function should comply with ADA. There opening to the trash should have a push flap or similar and be a minimum of 10" x 10".

Sanitary Waste

A sanitary bin with modesty flap is provided to the right of the toilet. Position and function should comply with ADA.

Call for Aid Button

There should be a call for aid button adjacent to the toilet. Position and function should comply with ADA.

Toilet Seat Cover Dispenser

A dispenser for paper toilet seat covers should be located by the toilet. Position and function should comply with ADA.

Toilet Flush

A two button push / touch-less flush is located on the back wall providing standard and eco flush. Position and function should comply with ADA.

Toilet

The toilet has a seat and a lid. The form of the toilet should be floating or undercut at the bottom to maximize wheelchair clearance. The design of the toilet, access and lid design will be subject to testing and ergonomic review during mockup stages and subject to the approval of Amtrak. Toilet seat and seat lid should all have soft close mechanisms.

ATR | Amenities and Features

26-FD-10416 0000004272 "UNCLASSIFIED" 4/20/2016

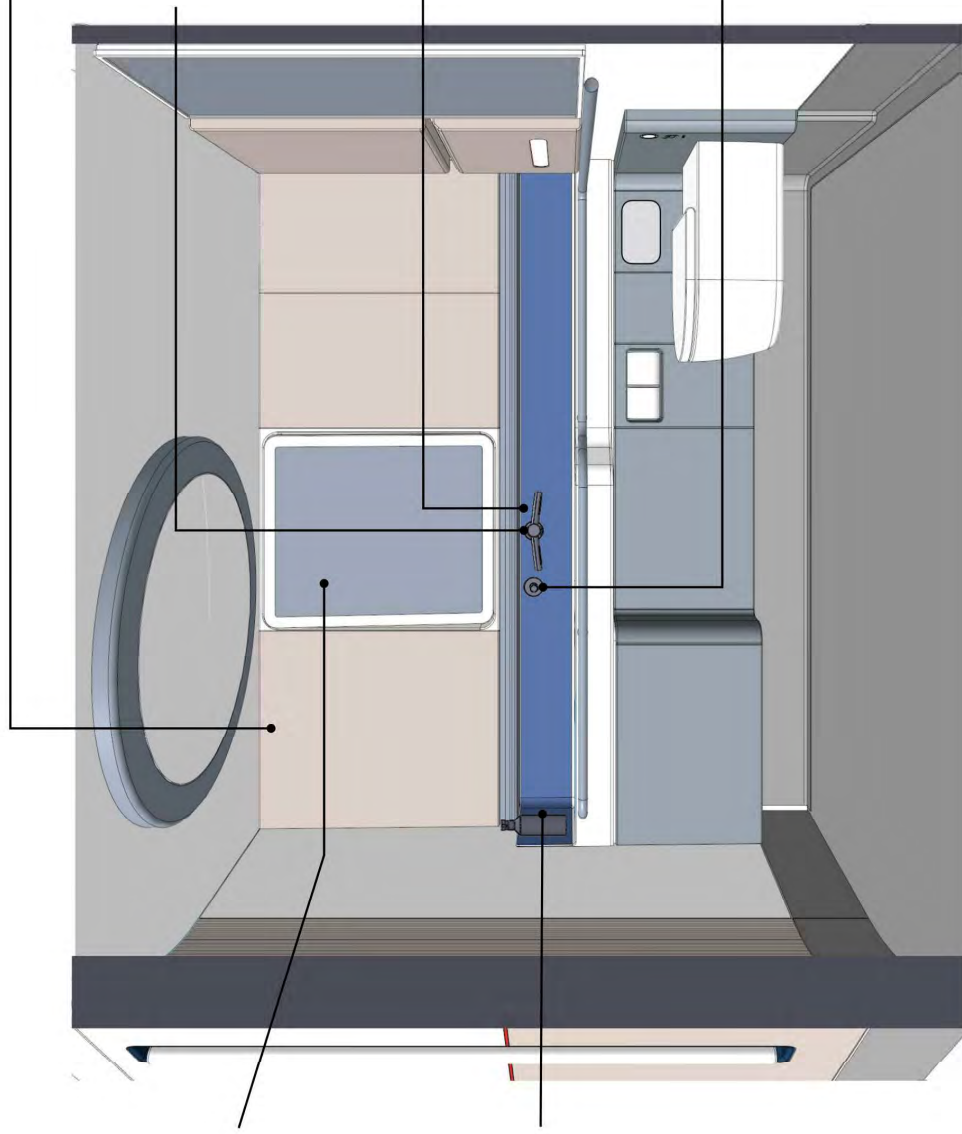

Vanity Mirror

A large mirror is positioned in front of the sink. The bottom edge of the reflective surface should be a maximum of 40" above the finish floor. If this is not possible, the mirror should be angled with an accessible lever to allow wheelchair passengers to use. Dimensions, position and usability will be subject to Amtrak approval.

Hand Lotion Bottle

An area on the side of the sink should be reserved for a refillable hand lotion bottle fixed to the side wall.

Crew Cabinet

Cabinet storage should be provided for crew to store cleaning and bathroom provisions.

Automatic Water Faucet

Water is automatically dispensed when hands are placed under the faucet. A physical element should be visible so it is clear where water is dispensed from. Temperature of water should be controllable. Water pressure, water flow should not create any water splash or spill outside of the sink area.

Automatic Hand Dryer

An automatically triggered hand dryer should be included under the vanity unit. This can be part of the faucet or supplied separately. A physical element should be visible so it is clear how to use the dryer. The dryer should use high velocity air and HEPA filters similar to a Dyson Airblade. The air dryer should not blow water out of the sink.

Soap Dispenser

An automatic soap dispenser should be included above the sink area. A physical element should be present to indicate how and where the soap will dispense.

ATR | Amenities and Features

26-F-01-0416 0000004272 "UNCLASSIFIED" 4/20/2016

Sharps Bin

Provision for a sharps bin should be provided within the room. The size and position and means of removal of sharps should be agreed and instructed by Amtrak.

Sink Surface

Sink surface should be large enough to store a wash bag and toiletry items and aid the safe and clean disposal of a colostomy bag. Marine edge should run along entire length and a draining surface angled towards sink.

Sink

The sink should be accessible while sat on the toilet. There should be an RVAC compliant clearance underneath the sink to allow wheelchair passengers to fully access the sink and amenities.

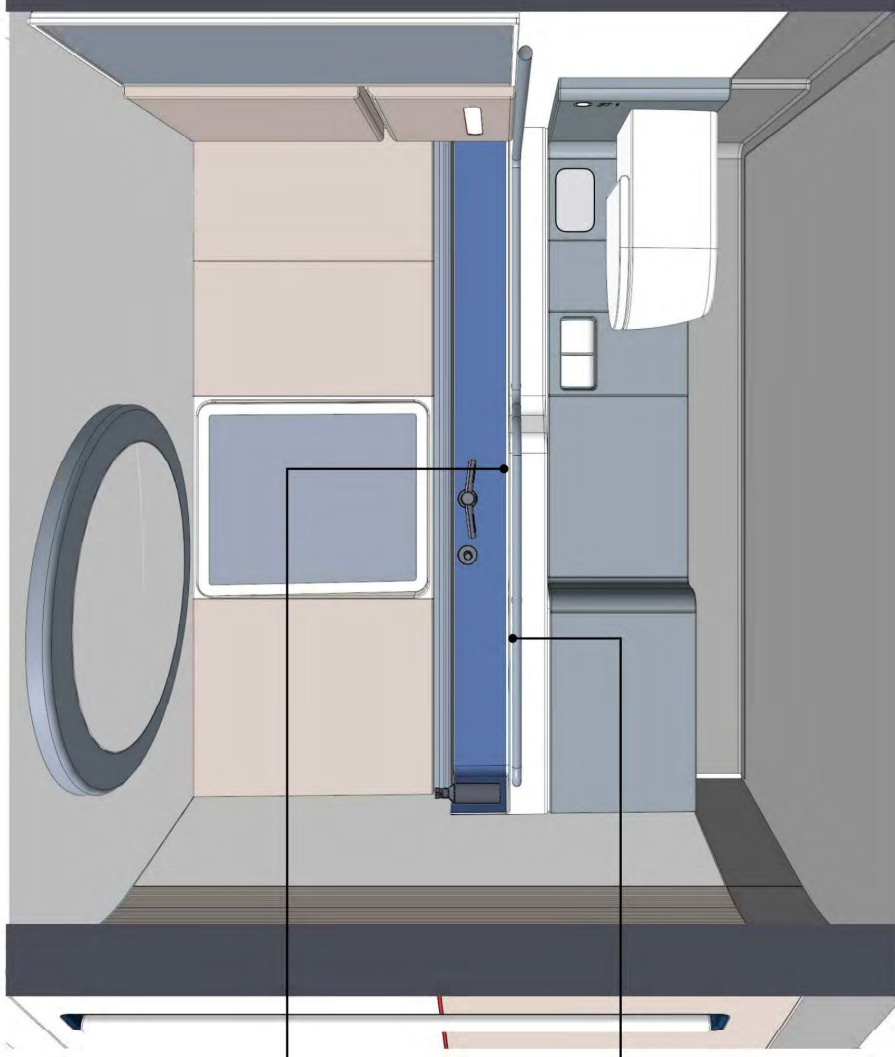

Intercom

A speaker should be provided in the toilet, passengers should be able to control notifications via the in room screen.

Extraction Fan

A filtered exhaust fan in the bathroom suitable to remove excess moisture, odors, and stale air.

ATR | Amenities and Features

26-FD-0416 000004272 "UNCLASSIFIED" 4/20/2016

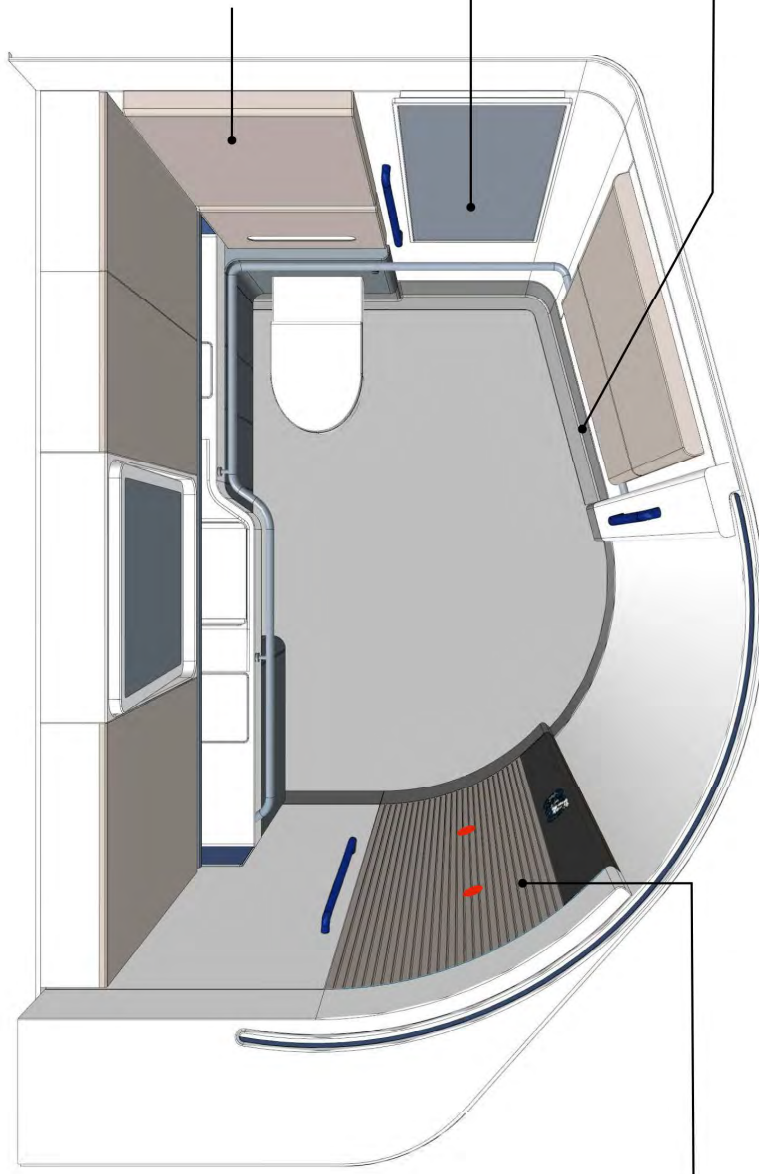

Fold Down Baby Changing

A baby changing table should be provided with an RVAC compliant clear space in front of it. The changing table should be easy to deploy and stow with an intuitive handle. It should have a soft opening mechanism. Position and function should comply with ADA.

Full Length Mirror

A full length mirror should be provided in addition to the sink mirror. The bottom edge of the reflective surface should be a maximum of 40" above the finish floor.

Coat Hooks

At least two coat hooks should be provided. One hook must be within the reach range of a person using a wheelchair at a maximum height of 45".

Soft Corners

The bathroom should have soft corners to aid cleaning and maintenance. The profile should not affect any clearance required for accessible space or turning spaces.



SP-01416 000004272

UNCLASSIFIED

430204

ATR | Lighting

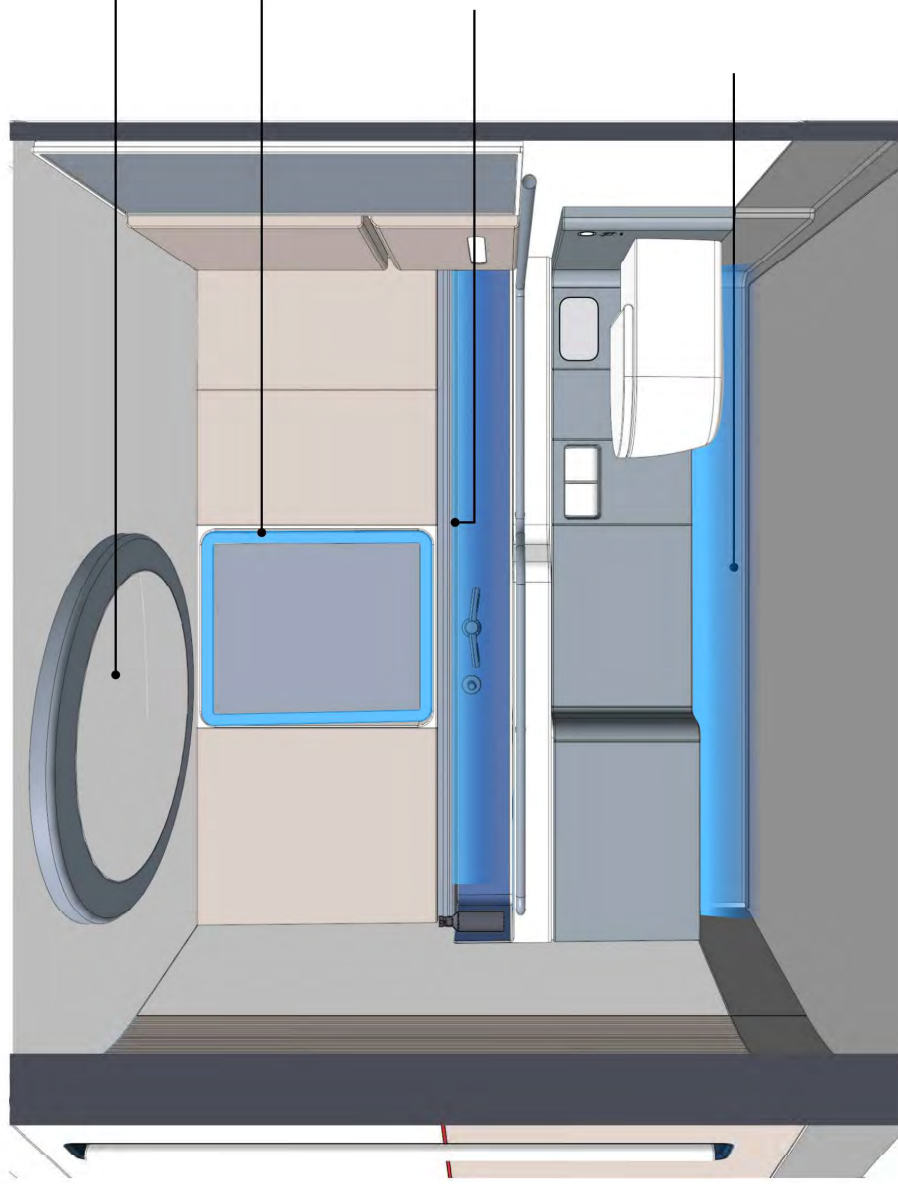

Ceiling Light Panel

A large circular LED panel light in the ceiling provides the main source of light for the room.

LED Illuminated Mirror

The vanity mirror is illuminated with an LED strip around the border. Activated when the door is locked from the inside.

Vanity Wash Light

The cabinet washes indirect mood light on to the sink surface. Activated only when door is locked from the inside.

Floor Wash Light

Lower sidewall panels wash indirect mood light on to the floor. Activated only when door is locked from the inside.



3547010416 0000002772 UNCLASSIFIED 4/20/24

- Coach Areas
- Sleeper Bedrooms
- Food & Beverage
- Toilets & Showers**
- Common Use Areas

Amtrak® Long Distance Product Features

12 | Standard Toilet Room

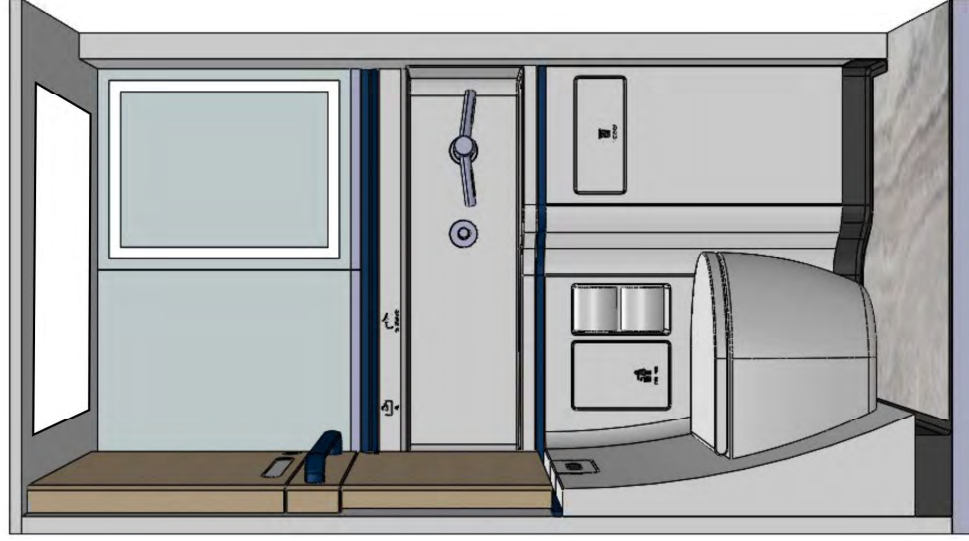

The Standard Toilet Room

The Standard Toilet Room is a compact space packed full of customer features.

The module is used in both coach and sleeper cars. A slightly differently CMF is applied to each of these spaces to denote the two different classes of travel.



25-FD-0416 000004272 UNCLASSIFIED 4/2/2016

STR | Room Features

STR | Amenities and Features

26-FO-0416 000004272 "UNCLASSIFIED" 4/20/2016

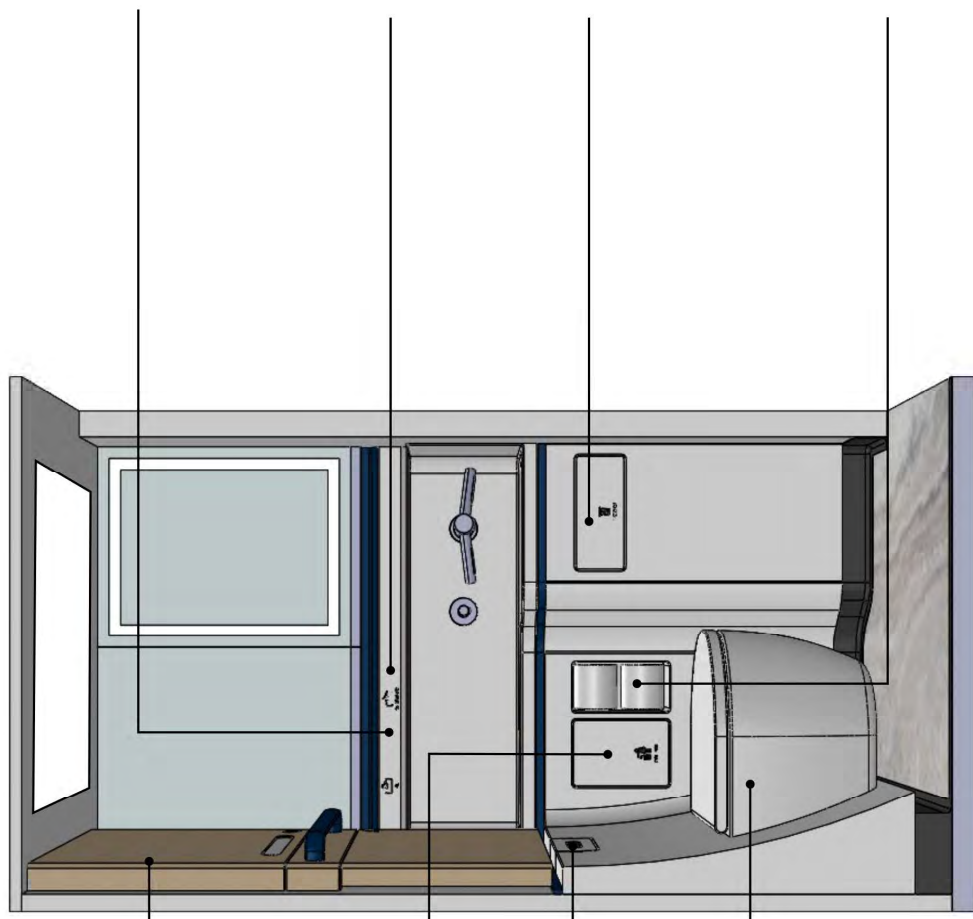

Toilet Seat Cover Dispenser
A dispenser for paper toilet seat covers should be located above the toilet.

Paper Tissue Dispenser
A paper tissue dispenser should be positioned near the trash and sink.

Sanitary Waste
A sanitary bin with modesty flap should be provided next to the toilet. Minimum volume of 7 Gal.

Paper Towel Dispenser
A paper towel dispenser should be positioned near the trash and sink.

Toilet Flush
A two button push / touch-less flush is located on the back wall providing standard and eco flush.

Trash
A trash bin is provided by the sink

Toilet
The toilet has a seat and a lid. The area under the toilet should be easy to clean. Toilet seat and seat lid should all have soft close mechanisms.

Toilet Paper Storage
The toilet paper should be stored in the wall of the bathroom and should be protected from spills from the sink.

STR | Amenities and Features

26-FO-10416 0000004272 "UNCLASSIFIED" 4/20/2016

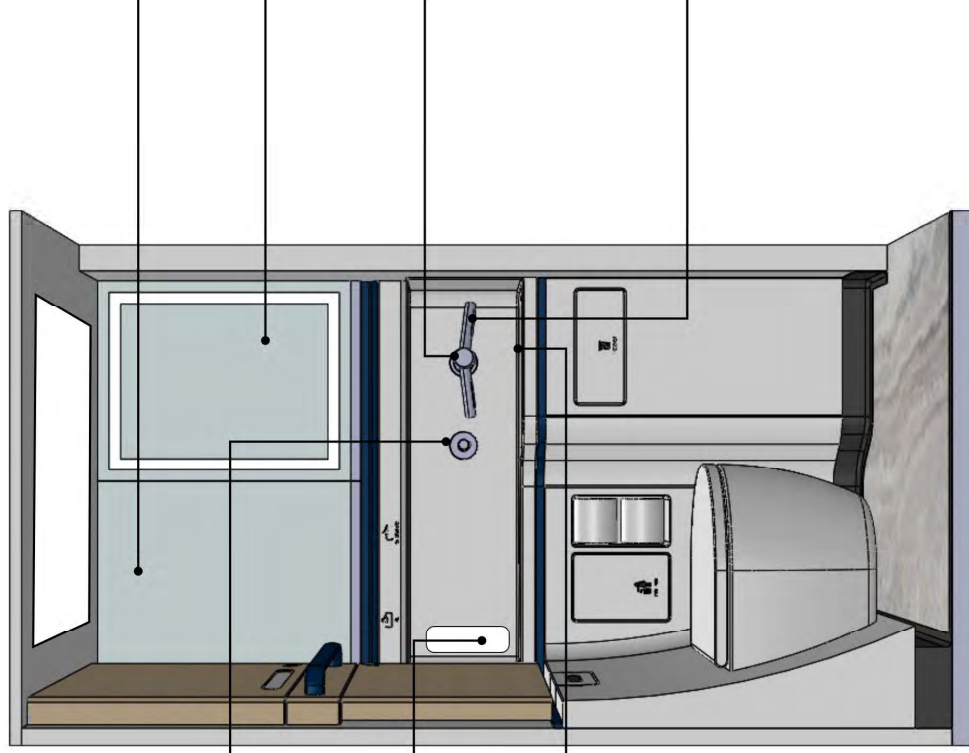

Soap Dispenser

An automatic soap dispenser should be included above the sink area. A physical element should be present to indicate how and where the soap will dispense.

Hand Lotion Bottle

An area on the side of the sink should be reserved for a refillable hand lotion bottle fixed to the side wall.

Sink

The sink should have a marine edge so any water spill is captured in the sink area. A splash back behind the sink should protect the surrounding areas from water splashed onto the back wall from the sink area.

Crew Cabinet

Cabinet storage should be provided for crew to store cleaning and bathroom provisions.

Vanity Mirror

A large mirror is positioned in front of the sink. Dimensions, position and usability will be subject to Amtrak approval.

Automatic Water Faucet

Water is automatically dispensed when hands are placed under the faucet. A physical element should be visible so it is clear where water is dispensed from. Temperature of water should be controllable. Water pressure, and water flow should not create any water splash or spill outside of the sink area

Automatic Hand Dryer

An automatically triggered hand dryer should be included under the vanity unit. This can be part of the faucet or supplied separately. A physical element should be visible so it is clear how to use the dryer. The dryer should use high velocity air and HEPA filters similar to a Dyson Airblade. The air dryer should not blow water out of the sink.

STR | Amenities and Features

25-FD-10416 0000004272 "UNCLASSIFIED" 4/20/2016

Intercom

A speaker should be provided in the toilet, passengers should be able to control notifications via the in room screen.

Coat Hooks

At least two coat hooks should be provided.

Fold Down Baby Changing

A baby changing table. The changing table should be easy to deploy and stow with an intuitive handle. The mechanism should be durable, free from jamming and racking. The design should meet abuse loads. It should have a soft opening mechanism.

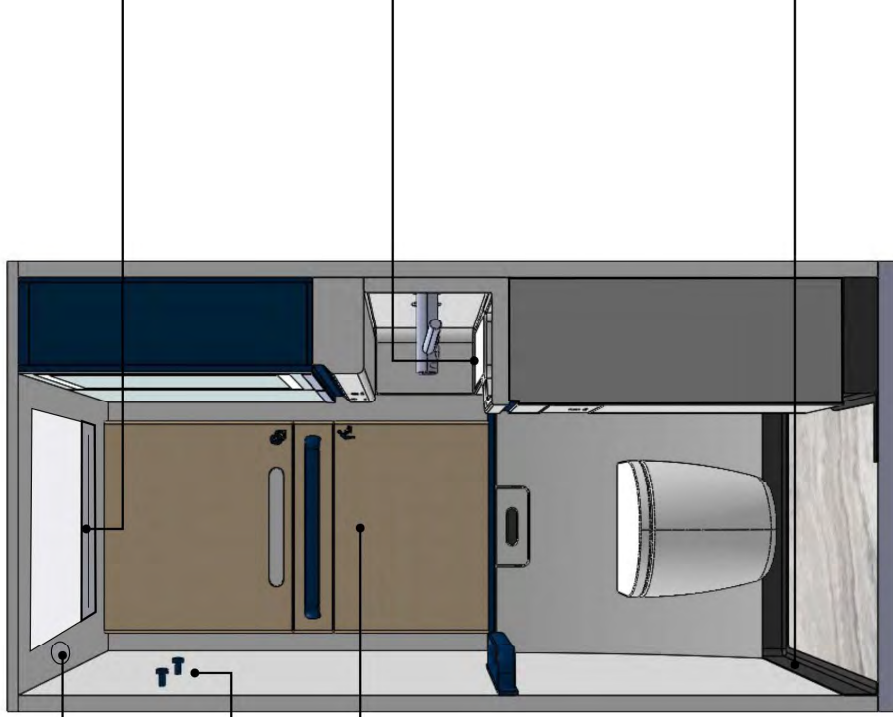

Extraction Fan

A filtered exhaust fan in the bathroom suitable to remove excess moisture, odors, and stale air.

Sink Surface

Sink surface should be large enough to store a wash bag and toiletry items and aid the safe and clean disposal of a colostomy bag. Main edge should run along entire length and a draining surface angled towards sink.

Soft Corners

The bathroom should have soft corners to aid cleaning and maintenance.

STR | Amenities and Features

25-F010416 0000004272 "UNCLASSIFIED" 4/20/2016

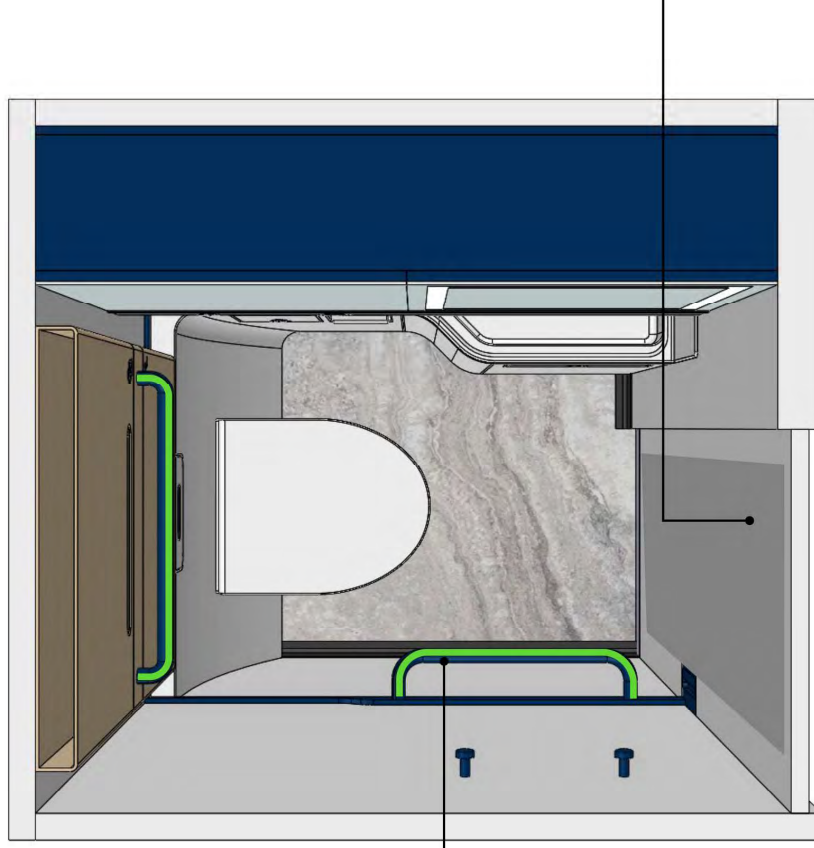

Handholds

Compliant handholds should be provided within the toilet. At least one should be provided behind the toilet and one on the side wall.

22" Toilet Door

The Toilet door can be sliding door or bifold door (much like an aircraft toilet door) - rattle free and free from racking or jamming. An internal lock with lock status indicator with accessible locks handle design. Emergency external unlock with crew key.



SP-01416 000004272

UNCLASSIFIED

430204

STR | Lighting

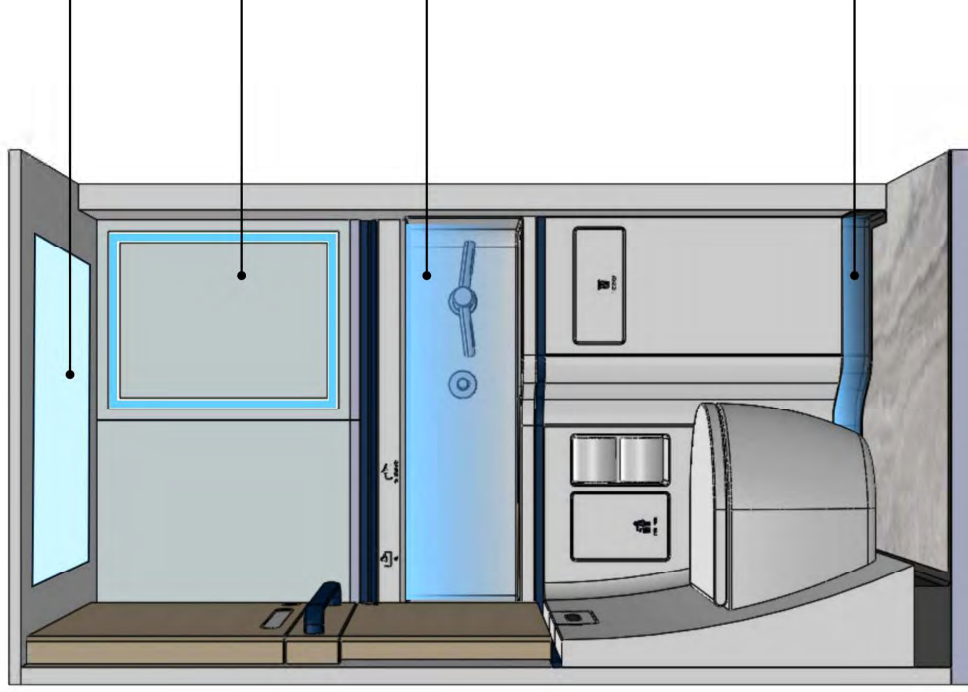

Ceiling Light Panel

A large rectangular LED panel in the ceiling provides the main source of light for the room.

LED Illuminated Mirror

The vanity mirror is illuminated with an LED strip around the border. Activated when the door is locked from the inside.

Vanity Wash Light

The cabinet washes indirect mood light on to the sink surface. Activated only when door is locked from the inside.

Floor Wash Light

Lower sidewall panels wash indirect mood light on to the floor. Activated only when door is locked from the inside.



2547010416 0000002772 UNCLASSIFIED 4/2024

Coach Areas
Sleeper Bedrooms
Food & Beverage
Toilets & Showers
Common Use Areas

Amtrak® Long Distance Product Features

13 | Shower & Changing Room

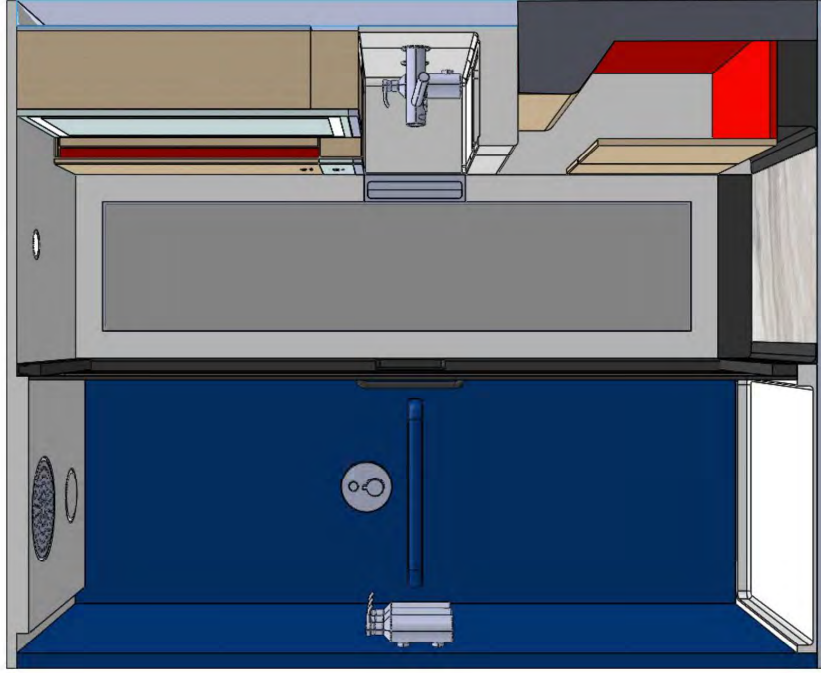

The Shower & Changing Room Room

The Shower & Changing Room designed for sleeper cars only.

The room provides a large shower, a changing area and a vanity area, with towel storage and a towel bin.



25-FD-0416 000004272 UNCLASSIFIED 4/20/24

Shower & Changing Room | Room Features

Shower & Changing Room | Amenities and Features

26-FD-0416 000004272 "UNCLASSIFIED" 4/20/2016

Handholds
Suitable handholds should be positioned to aid people while standing in the shower and the changing area. The sizes will be subject to mockup testing and Amtrak approval.



Shower Tray

The shower tray should be a minimum of 27" x 40" and be fully sealed and easy to clean.

Changing Area

The standing changing area in front of the changing bench should be a minimum of 24" x 30"

Shower & Changing Room | Amenities and Features

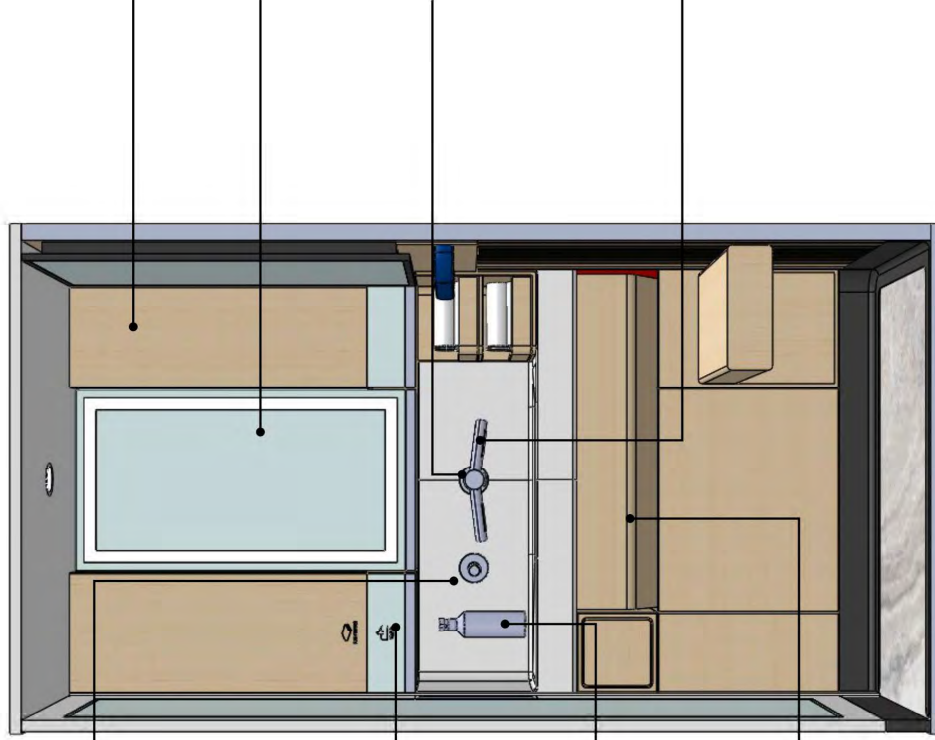

Soap Dispenser

An automatic soap dispenser should be included above the sink area. A physical element should be present to indicate how and where the soap will dispense.

Crew Cabinet

Cabinet storage should be provided for crew to store cleaning and bathroom provisions.

Vanity Mirror

A mirror is positioned in front of the sink of 18" wide and x 33" in height. The volume behind is reserved for hand dryer and soap equipment.

Paper Tissue Dispenser

A paper tissue dispenser should be positioned near the trash and sink.

Automatic Water Faucet

Water is automatically dispensed when hands are placed under the faucet. A physical element should be visible so it is clear where water is dispensed from. Temperature of water should be controllable. Water pressure, water flow should not create any water splash or spill outside of the sink area

Hand Lotion Bottle

An area on the side of the sink should be reserved for a refillable hand lotion bottle fixed to the side wall.

Automatic Hand Dryer

An automatically triggered hand dryer should be included under the vanity unit. This can be part of the faucet or supplied separately. A physical element should be visible so it is clear how to use the dryer. The dryer should use high velocity air and HEPA filters similar to a Dyson Airblade. The air dryer should not blow water out of the sink.

Towel Bin

The space under the sink should be maximized for storing used towels with a minimum volume of 30 Gal. The bin should be lined, prevent water ingress and build up of mould.

Shower & Changing Room | Amenities and Features

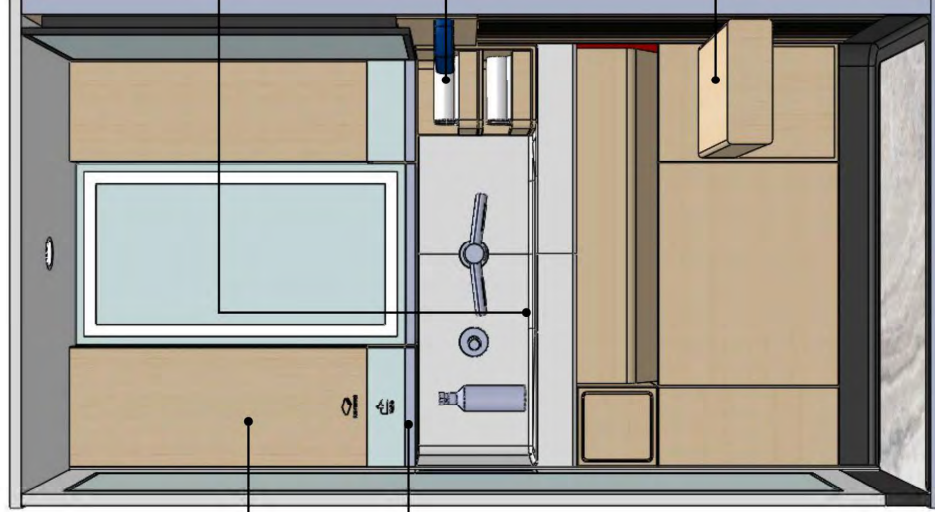

Bath Towel Cabinet

A cabinet for storing a minimum of 15 clean Amtrak bath towels

Braille Strip

A Braille strip should be provided along the underside of the vanity unit to call out key functions of the vanity area - water, air, tissues, towels etc

Sink Surface

Sink surface should be large enough to store a wash bag and toiletry items. Marine edge should run along entire length with a draining surface angled towards sink.

Hand Towel and Wash Cloth

Space should be provided on the vanity unit to stack hand towels and wash cloths.

Changing Bench

A cantilevered bench should be provided in the changing area with space kept free under the seat for a bag. The bench should have a minimum depth of 11.5" running the full width of the changing area

Shower & Changing Room | Amenities and Features

26-FD-10416 0000004272 "UNCLASSIFIED" 4/20/2016

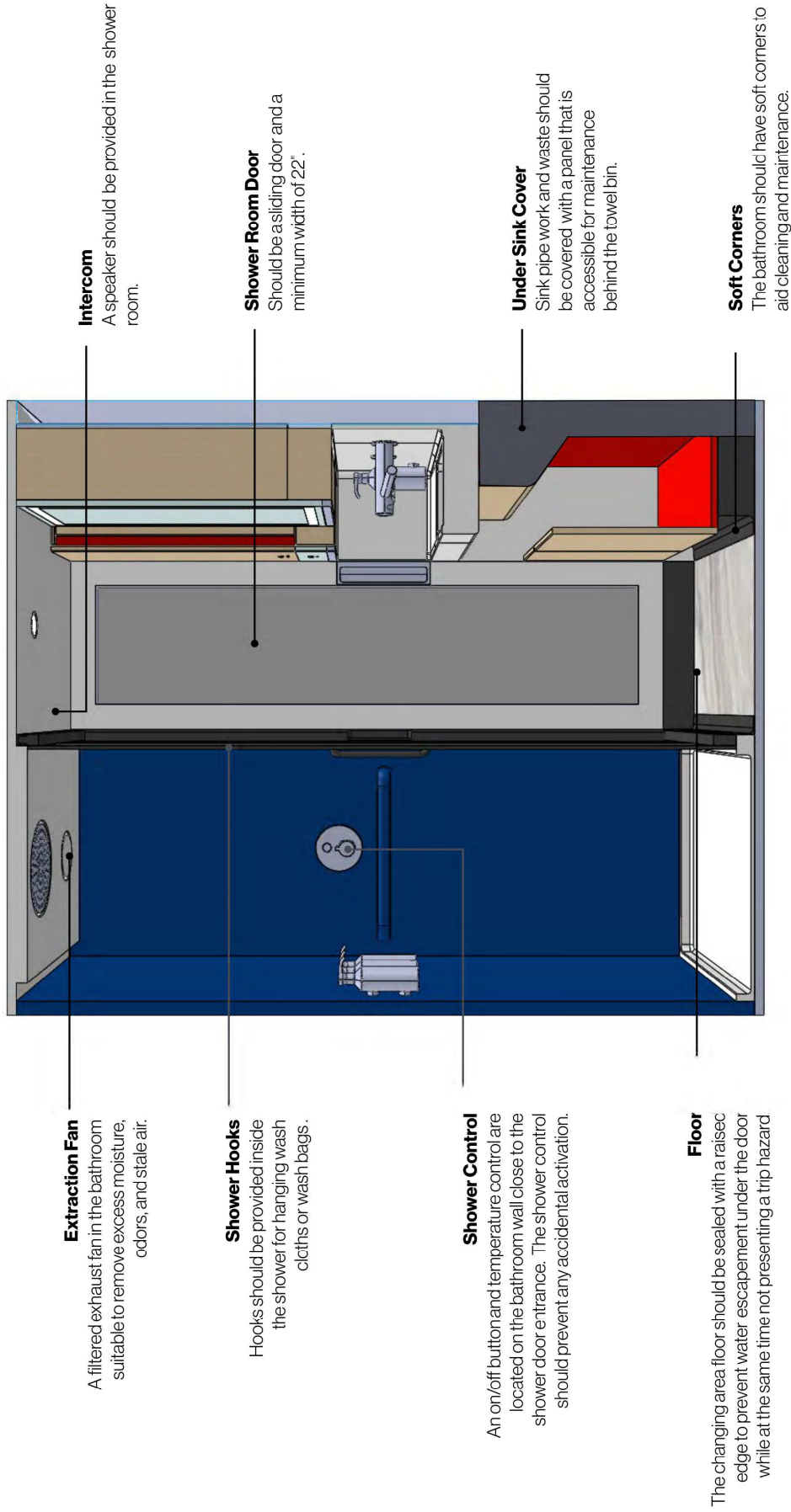

Shower & Changing Room | Amenities and Features

25-F-01-0416 0000004272 "UNCLASSIFIED" 4/20/2016

Coat Hooks

Coat hooks should be provided close to the shower door inside the changing area and protected from shower splash for hanging clothes and towels.

Fixed Glazed Panel

A fixed glaze panel should be used to keep the shower space open and bright. The lower portion can be solid to provide structure for the cantilever benches.

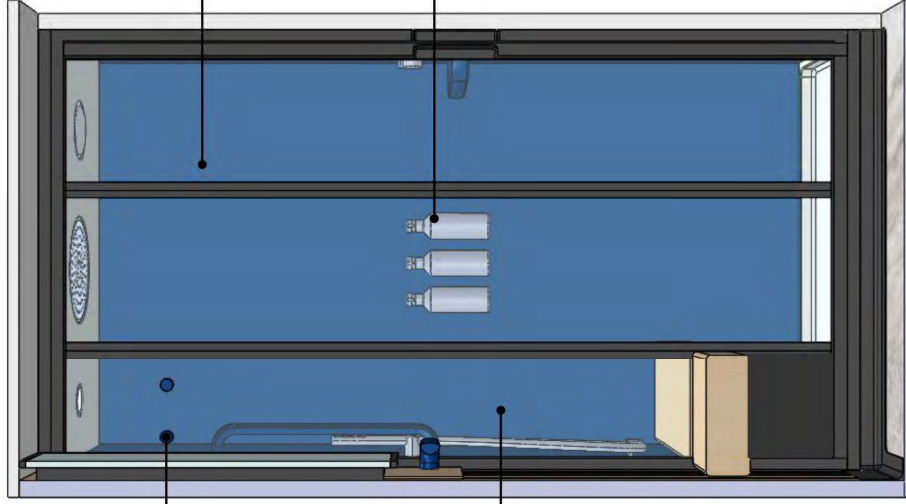

Shower Door

The door should open inwards as a bifold door, similar to an airline toilet door. The door should be sealed to prevent shower water escaping into the internal living space of the room, even when water is sprayed directly onto the back surface of the door.

Dispensing Bottles

3 refillable Amtrak bottles dispensing shampoo, conditioner and body lotion. Bottles should be fixed to the wall and easily refilled or replaced by Amtrak staff.

Shower & Changing Room | Amenities and Features

25-FD-10416 000004272 "UNCLASSIFIED" 4/20/2016

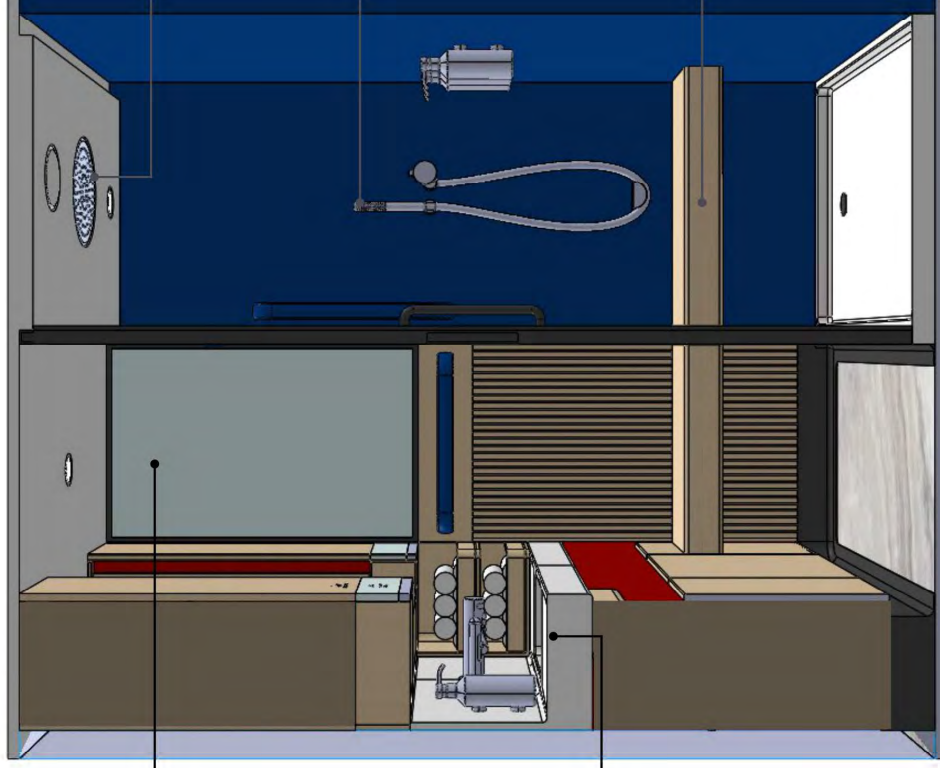

Mirror
A second mirror should be provided in the changing area

Rain Shower
A rain shower in the ceiling provides a shower above head height. Rain shower should be seamlessly integrated into the ceiling in order to maximize head room in the bathroom.

Hand Shower
A second hand shower is located with a slimline design handset. A hose clip should be included to prevent the hose from rattling while the train is in transit.

Sink
The sink should have a marine edge so any water spill is captured in the sink area. A splash back behind the sink should protect the surrounding areas from water splashed onto the back wall from the sink area.

Shower Seat
A fixed cantilevered shower seat should be provided inside the shower with an anti-slip finish with a minimum depth of 11.5" turning the full width of the shower enclosure.



25-FD-0416 000004272 UNCLASSIFIED 4/2/2016

Shower & Changing Room | Lighting

Shower & Changing Room | Lighting

25-F-01-0416 0000004272 "UNCLASSIFIED" 4/20/2016

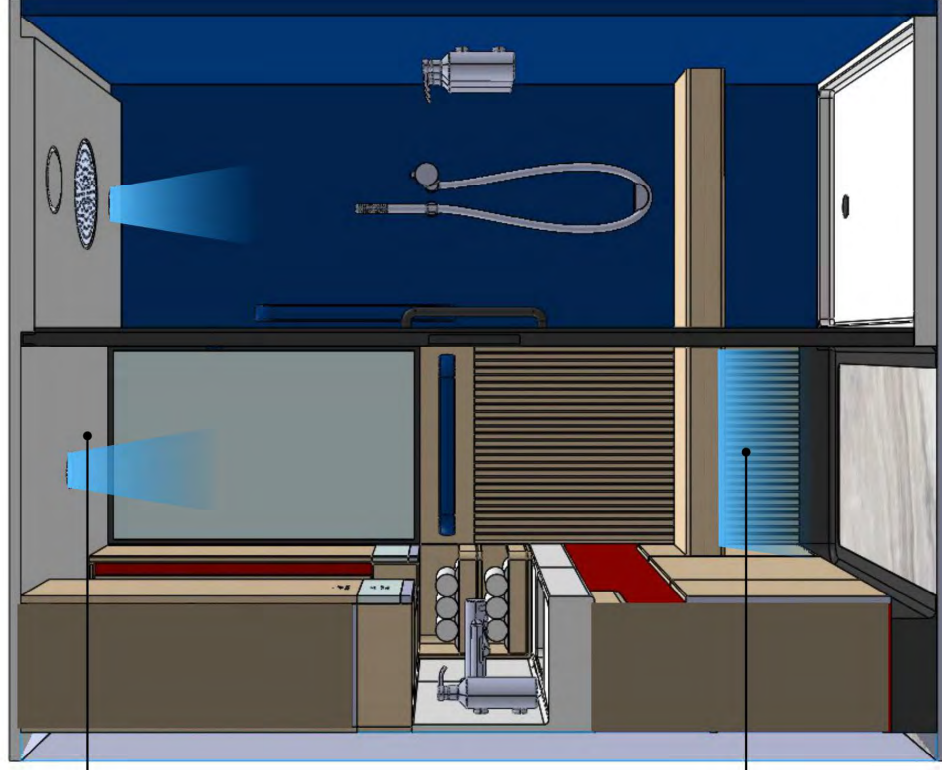

LED light panel spots

Small circular LED light panels act as spot lights to provide the master lighting conditions for this room - frame to be color matched. At least one in the changing area and at least one in the shower enclosure.

Bench Wash Light

Indirect mood light on to the floor from the underside of the bench. Activated only when the door is locked from the inside.

Shower & Changing Room | Lighting

25-FD-10416 0000004272 "UNCLASSIFIED" 4/20/2016

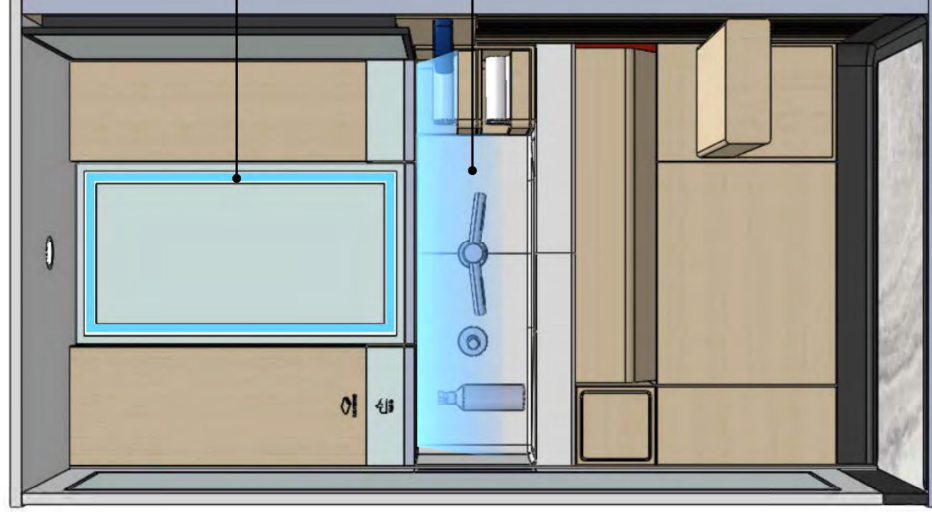

LED Illuminated Mirror

The vanity mirror is illuminated with an LED strip around the border. Activated when the door is locked from the inside.

Splash Back Wash Light

The cabinet washes indirect mood light on to the sink surface. Activated only when the door is locked from the inside.



25-F-01-0415 000000272 UNCLASSIFIED 4/2024

- Coach Areas
- Sleeper Bedrooms
- Food & Beverage
- Toilets & Showers
- Common Use Areas**

Amtrak® Long Distance Product Features

14 | Entrance Area

Handholds
Compliant handholds should be supplied on both sides of each door, at key access point along aisles and on both sides of elevators.

Tide line
There should be a horizontal tide line incorporated into the panel work. The edging between upper and lower panel acts as class identifier.

Kick-strips
Stainless steel kick strips at 9" high.

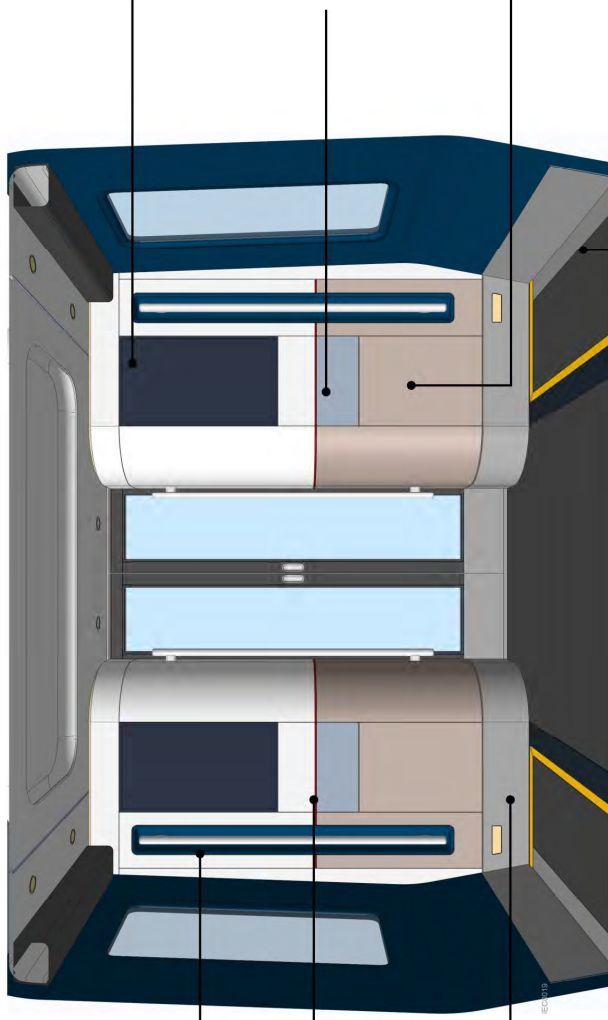

Passenger Information Screens
Display screens should be supplied on both sides of the door.

Trash Bin
Trash bins on both sides vestibule with stainless steel push flaps. Easy access water tight bin liner for quick cleaning routines and maintenance.

Panel Work
Vestibule monuments should be designed to have well fitted clean panel with a high tolerance build to manage split lines and cabinet edging. There should be no protruding equipment, snag point or dirt traps. All equipment cabinets should be accessible under a crew key with discreet locks.

Door Threshold
Should have a slip-free surface and a contrasting floor color to the main vestibule flooring to mark the threshold.

Entrance Area | Lighting

25-FD-10416 0000004272 "UNCLASSIFIED" 4/20/2016

Ceiling Pool Light

Central lighting well in the ceiling provides indirect mood wash light in the centre of the vestibule.

Module Wash Lights

Indirect strip lights wash light onto the ceiling from the top of the vestibule monuments..

Step Lights

Step lights should illuminate interior threshold during boarding sequences.

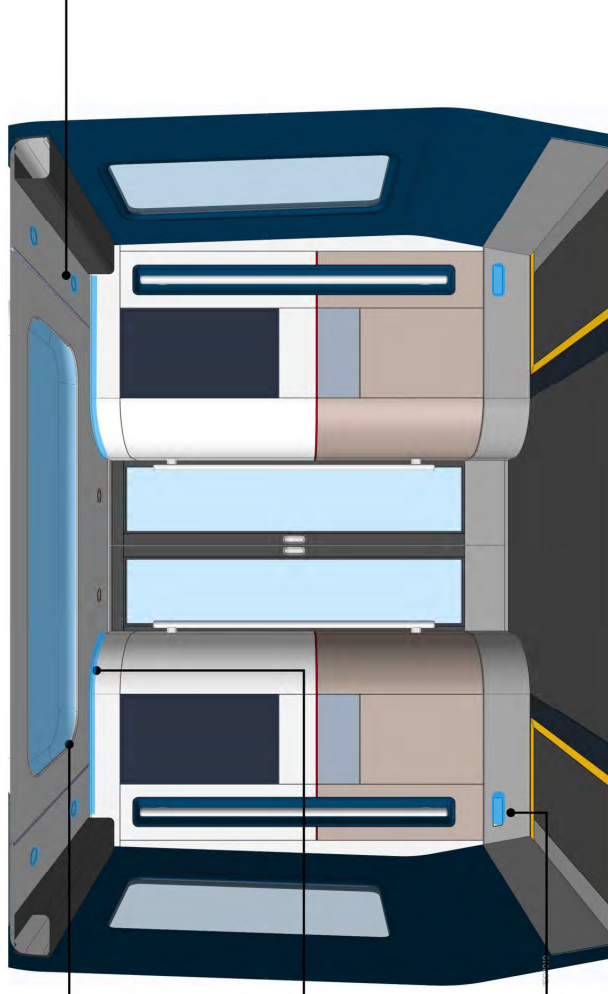

LED Panel Spot Lights

Spot light over door, elevators and along aisles. Size position and number will be subject to Amtrak approval.



34-7010416 000002772 "UNCLASSIFIED" 420024

Coach Areas

Sleeper Bedrooms

Food & Beverage

Toilets & Showers

Common Use Areas

Amtrak® Long Distance Product Features

15 | Interior Structure

Interior Structures | Coach

26-FD-10416 0000004272 "UNCLASSIFIED" 4/20/2016

Luggage Shelf

Luggage shelf should be built in modules that align with window placements. Split lines and module length should be consistent and to visually match the window module splits.

Reservation Screens

Passenger information displays should be integrated with the rack design. The position of the seat reservation module should be designed so they can easily be moved in case seat pitch or density is modified in the future.

Coat Hooks

Coat hooks should be provided for each seated location, integrated with the luggage shelf. Hooks should be easy to move if seat positions or seat pitch is changed in the future.

*Rotating Seats

In the case of rotating seats, seat reservation systems, at seat power and coat hooks, locations will need to work in both seat orientations.

Blinds

A single pull-down blind system shall be provided per window, capable of delivering both daytime solar/glare control and full blackout performance. Blinds should cover the entirety of the window.

Windows

Window size should be maximized with an equal pitch. Window mask should minimize or mask glass corners to create an architectural aesthetic.

Window Pillars

Window pillar width should be minimized. The pillar trim should continue over the side ceiling to create an arched aesthetic.

Lower Side Wall Panel

A lower side wall panel provides a horizontal tideline and material split

Kick-strips

Stainless steel kick strips at 9" high.

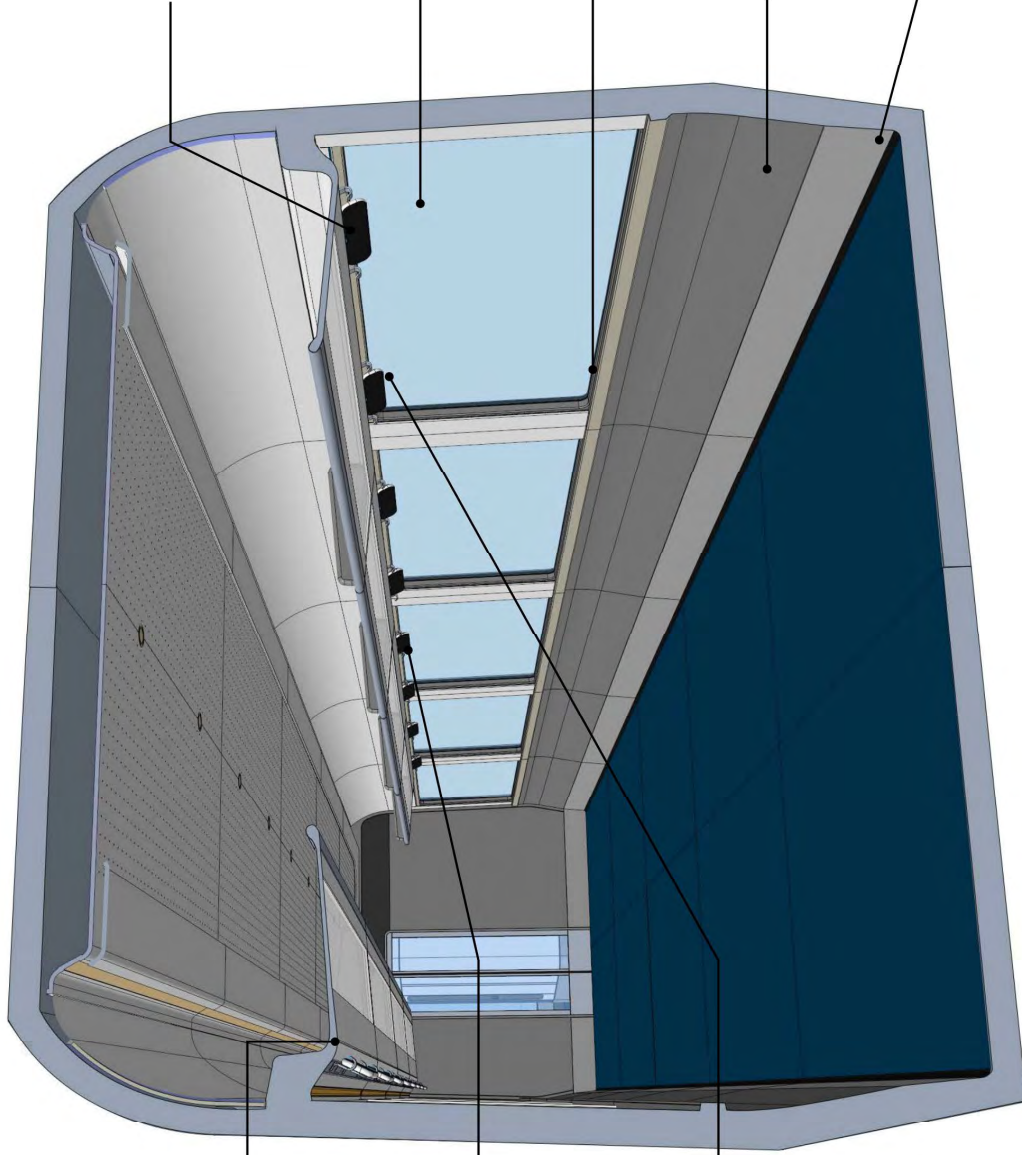

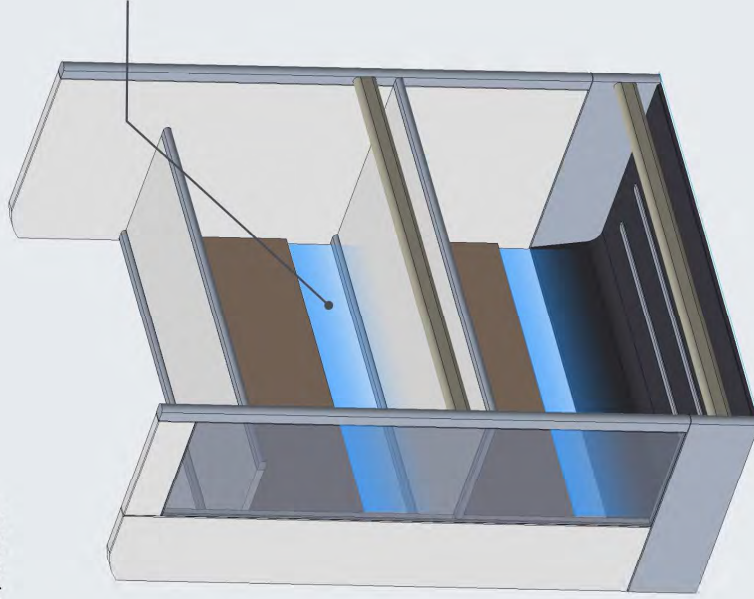

Shelf Lighting

Luggage towers shall have shelf lighting integrated within the tower.

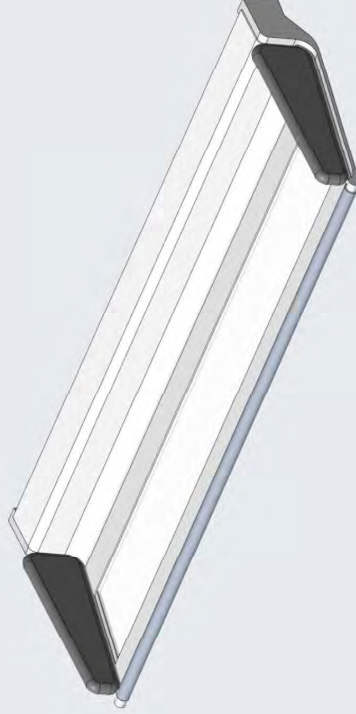

Luggage Shelf

Overhead luggage racks shall be modular and constructed using extruded aluminum to allow different length segments. Rack modules and split lines shall align with window placements and visually correspond with the window module divisions. Coat hooks shall be provided for each seated location and integrated within the luggage rack assembly.

Luggage Tower

Luggage towers shall be constructed as a modular system allowing various tower lengths. Glass side panels shall be provided to allow passengers to view their luggage

Interior Structures | Cafe, Diner, Lounge

26-FD-10416 0000004272 "UNCLASSIFIED" 4/20/2016

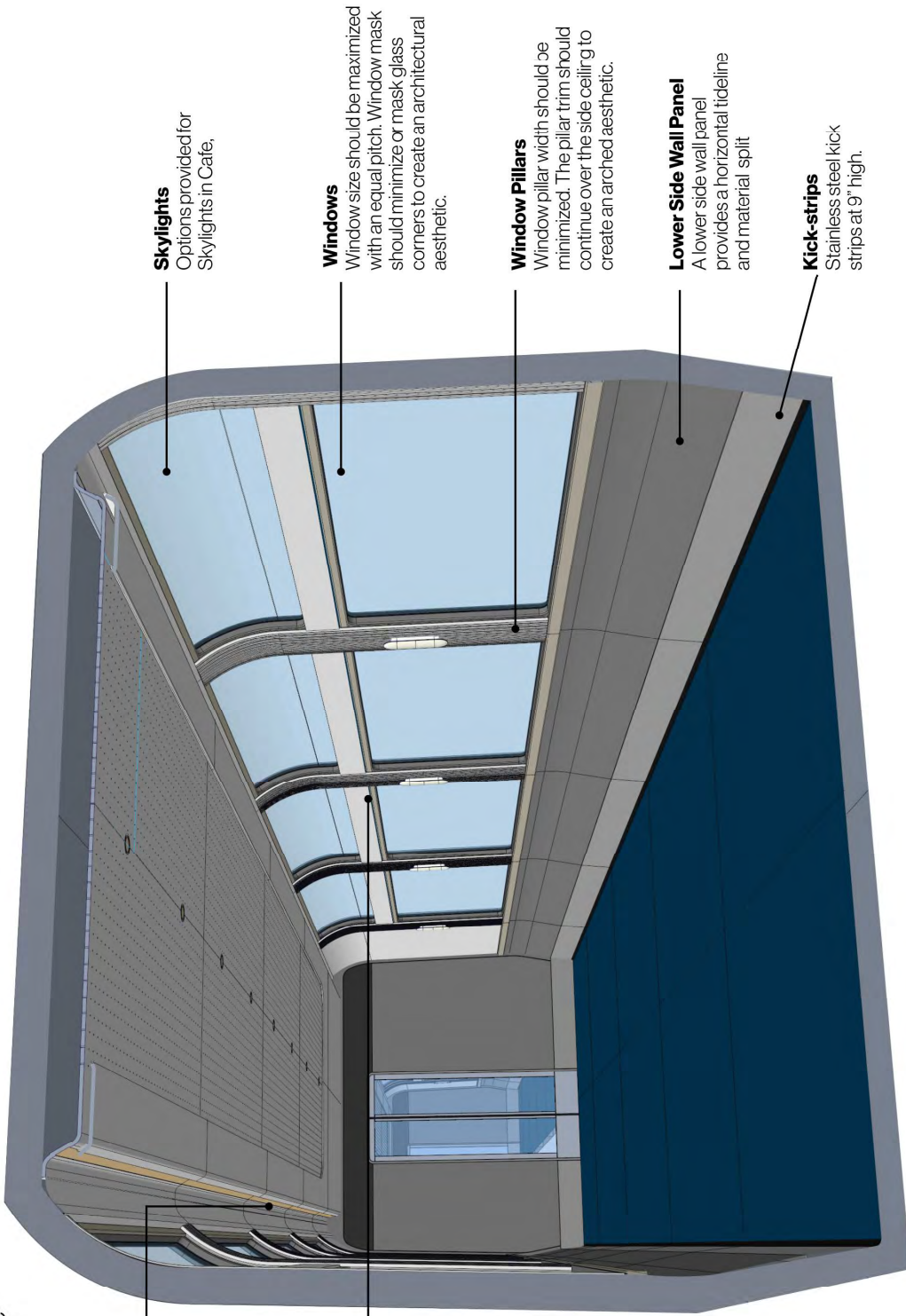

Blinds
A single pull-down blind system shall be provided per window, capable of delivering both daytime solar/glare control and full blackout performance. Blinds should cover the entirety of the window. Skylight blinds to be crew controlled

Blind Pelmet
Blinds shall be stored in a pelmet so that they can easily be accessed for maintenance. to be crew controlled

Skylights
Options provided for Skylights in Cafe,

Windows
Window size should be maximized with an equal pitch. Window mask should minimize or mask glass corners to create an architectural aesthetic.

Window Pillars
Window pillar width should be minimized. The pillar trim should continue over the side ceiling to create an arched aesthetic.

Lower Side Wall Panel
A lower side wall panel provides a horizontal tideline and material split

Kick-strips
Stainless steel kick strips at 9" high.

Interior Structures | Lighting

25-F-01-0416 0000004272 "UNCLASSIFIED" 4/20/2016

Ceiling Lighting

Ceiling lighting should be consistent across all car types. Wash lighting from both sides of the lighting gondola lights central panel and side ceiling.

Spot Lighting

LED panel spot lights. Downlighting spots light the aisle.

Wall Lights

Additional wall lights shall be provided in Cate, Diner and Lounge areas

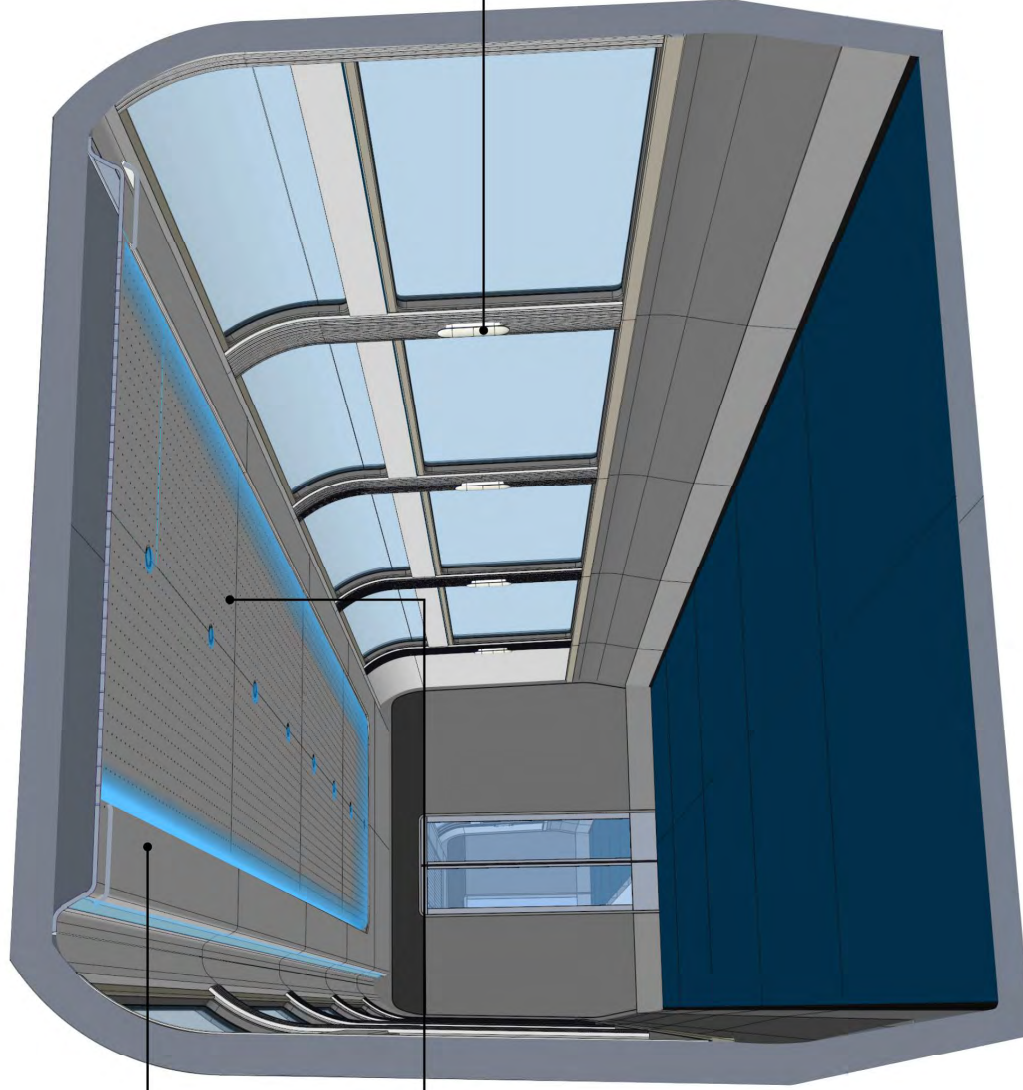



25-FD-0416 00000272 "UNCLASSIFIED" 4/2024

- Coach Areas
- Sleeper Bedrooms
- Food & Beverage
- Toilets & Showers
- Common Use Areas**

Amtrak® Long Distance Product Features

16 | Hallways

Hallways | Room Doors

26-FD-0416 000004272 "UNCLASSIFIED" 4/20/2016

Room Badge
Room numbering, room state signaling.

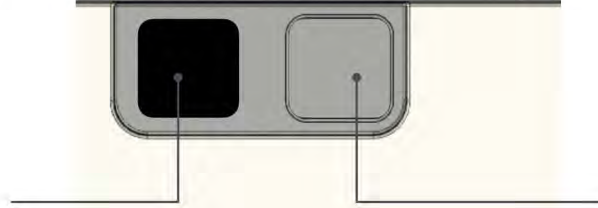

Handle
Accessible grip with callout contrasting color in class signifier.

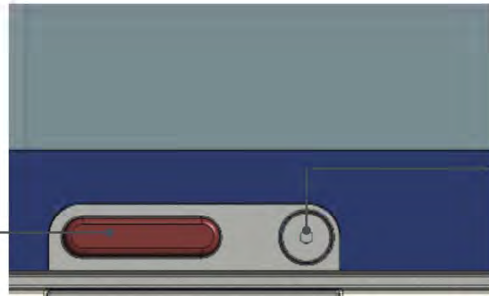

Keyless Entry
Technology defined elsewhere. Modular approach to panel so tech can be updated and swapped in the future.

Manual Override
External manual lock override with crew key.

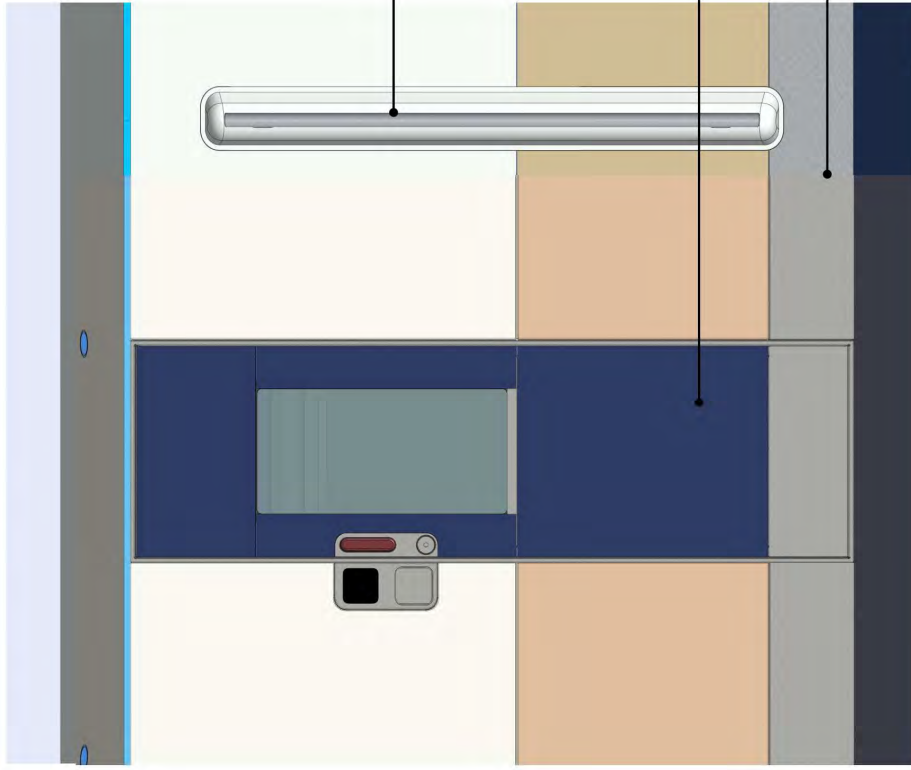

Handholds
Hallways should provide handholds either at junction between bedroom modules or along the side wall.

Doors
Sliding doors should be called out in a separate color in line with CMF attachment.

Kick-strips
Stainless steel kick strips at 9" on both sides of the aisle and across bottom top the door.

Hallways | Lighting

25-FD-10416 0000004272 UNCLASSIFIED 4/20/2016

Panel Spot lights
Spot lights provides
downlighting



Module Wash Lights

Indirect strip lights wash light onto the ceiling from the top of bedroom monuments.

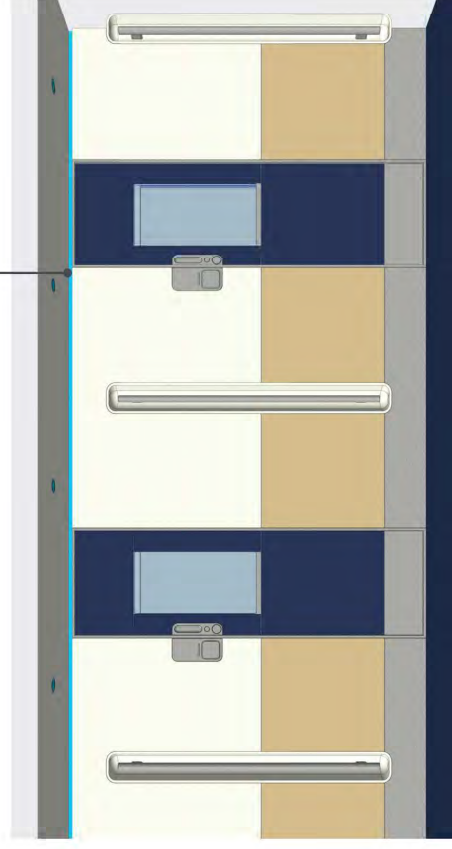



AMTRAK | AMTRAK | AMTRAK | AMTRAK

Thank you.



AMTRAK • AMTRAK • AMTRAK • AMTRAK

Long Distance **Color Material Finish**

Issued March 2026



AMTRAK
NATIONAL
4-2024

Amtrak® Long Distance CX Vision

CMF Schedule

CMF STRATEGY

The proposed material palette on the following page is indicative and intended to communicate the breadth, variety, and quality of applications expected across the new vehicles. While final colors and finishes will be developed and refined through the design process, the current palette sets out the ambition in terms of material diversity, durability, and overall customer experience.

Suppliers will be expected to accommodate this range through rounds of sampling and refinement to support performance, compliance, and aesthetic cohesion, as well as to align with iterative feedback and approvals from the Amtrak team.

COLOR PALETTE

SOFT MATERIALS

PRIMARY | Main Upholstery



Synthetic Leather or similar

SECONDARY | Highlight Upholstery / Class Identifier Palette



PRIMARY | Lounge + Diner Upholstery



Woven Fabric

PRIMARY | Blinds + Lamp shades



Polyester / Polyamide

SECONDARY | Stitch details



Polyester Yarn

HARD MATERIALS

PRIMARY | Main Hard Surfaces (Matched Colors)



HPL / Powder coated / Moulded polymer

SECONDARY | Highlight Hard Surfaces



PRIMARY | Feature Laminates



FEATURE | Counter Tops/ Sinks / Splash Backs



Solid Surface/ Feature Polymers

PRIMARY | Dividers/ Racks/ Stacks / Shower screens



Glass

PRIMARY | Brushed Stainless Steel / Anodized



Metal

FLOORING

PRIMARY | Vestibules, Restrooms, Food Service

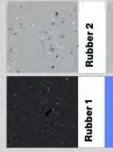

Anti-slip Rubber Floor

PRIMARY | Coach, Food Service



High Traffic Carpet

PRIMARY | Bedrooms



Low Traffic Carpet

SOFT MATERIALS

26-210-0416 0000004235 UNCLASIFIED 4/2024

Material	Technology/Construction	Texture/Pattern	Finish	Color	Coach Areas	Sleeper Bedrooms	Food Service Areas	Toilets & Showers	Common Use Areas
1 Synthetic Leather	Primary Upholstery	Various textures / Patterns (eg. Soft organic, Top Grain etc)	Matte	PMS 7699 C PMS Coc. Gray 9 C PMS 2165c PMS 202C PMS 539C PMS Warm Gray 9c PMS 3403 C PMS 306C PMS 483 C	Coach				
					Coach		Diner		
2 Woven fabric	32% wool/68% nylon Weight 1550 +/- 5% gm	As per sample	Matte	Base: PMS 7620 C Accent: Cool Gray 11 C Base: Warm Gray 9 C Accent: Cool Gray 11 C					
							Diner		
3 Polyester Yarn	3 ply	Various Patterns (Double top stitch + Single stitch line)	Various Finishes (Matte, Silky, Satin, etc)	PMS 7699 C PMS 539C PMS Coc. Gray 9 C					
4 Polyester / Polyamide	Solidified construction/medium light transmittance or Aluminium backed	Blackout backing TBD	Matte	PMS Cool Gray 9C PMS 539C		Door Blind Window Blind			

HARD MATERIALS

Material	Technology/Construction	Texture/Pattern	Finish	Color	Coach Areas	Sleeper Bedrooms	Food Service Areas	Toilets & Showers	Common Use Areas	
1 Stainless Steel / Aluminum	Stainless Steel Anodized Aluminum	Various (eg. Brushed, Smooth, VD.39)	Metallic	Natural PMS 1035C RAL 085 80 05 (Matched Color) RAL 9003 (Matched Color) RAL 7021 (Matched Color) PMS 539 C (Matched Color) PMS 539 C (Matched Color) PMS 483 C (Matched Color)						
2 High Pressure Laminate (HPL) or similar	Feature laminate	Wood Grain Marbled finish, naturally veined, varying intensity Ribbed / Stained pattern achieved through pressing or texturing	Matte	Native American Oak Refer to sample Native American Oak PMS 539 C PMS 483 C (Matched Color) PMS 539 C (Matched Color) PMS Cool Gray 6 C (Matched Color) RAL 9003 (Matched Color) RAL 085 80 05 (Matched Color) RAL 7021 (Matched Color)						
3 Moulded polymer or similar	Solid Colour Laminates	Various Textures / Patterns (eg. Smooth, Brushed, Sandblasted, VD.35 etc)	Various Finishes (Matte, Satin, Gloss, Metallic, etc)	PMS 483 C (Matched Color) PMS 539 C (Matched Color) PMS Cool Gray 6 C (Matched Color) RAL 9003 (Matched Color) RAL 085 83 05 (Matched Color) RAL 7021 (Matched Color)						
4 Solid Surface / Feature Polymer	No prescribed	Smooth Superior marbled finish naturally veined Small tile pattern	Matte	Pure White Refer to sample PMS 302 C						
5 Glass	Flat Fluted glass	Various (Clear, Frosted, Tint, Film, etc) Pattern at our blur space between each booth	-	Transparent						

FLOORING

24-FI-04416 0000002235 UNCLASSIFIED 4/20/2024

Material	Technology/Construction	Texture/Pattern	Finish	Color	Couch Areas	Sleeper bedrooms	Food & Beverage	Toilets & Showers	Common Use Areas
1 High Traffic Carpet 1	4-Thread, woven with high pile, extra wear, 100% Nylon. Low pile for optimum durability and resistance.	See sample reference	80% matte 20% luster	Base color: PMS 539 C Accent 1: PMS Cool Gray 1 C Accent 2: PMS Warm Gray 9 C Accent 3: PMS 7699 C					
2 High Traffic Carpet 2				Base color: PMS Black 7 C Accent 1: PMS Cool Gray 1 C Accent 2: PMS Warm Gray 9 C Accent 3: PMS 7699 C					
3 Low Traffic Carpet 3	Not prescribed			Base color: PMS 483 C Accent 1: RAL 9003 Accent 2: RAL 7021 Accent 3: RAL 7021					
4 Anti-slip Rubber Floor 1	synthetic rubber made of a colored compound mixed with multi-colored speckles of the same material which provides excellent anti-slip properties. Anti-slip rating to pass FH standard	Terrazzo like pattern	Fast curing two part epoxy resin based Polyurethane top coat for extra abrasion and chemical resistance	Base Color: NCS S8502-B Blue Accent: S6030-F90B Grey Accent: S0502-Y RAL 9003 RAL 7021					
5 Anti-slip Rubber Floor 2				Base Color: NCS S2002-B Blue Accent: S6030-F90B Grey Accent: S0502-Y RAL 9003 RAL 7021					

High Traffic Carpet

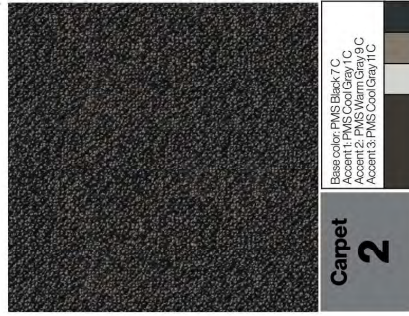
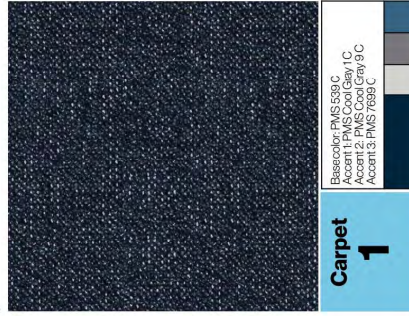

Low Traffic Carpet



Anti-slip Rubber Floor

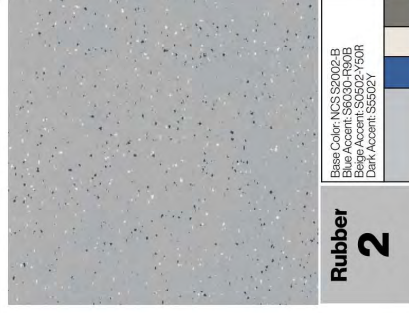

FLOORING

25-FI-010416 0000002235

UNCLASSIFIED

4/30/2024

High Traffic Carpet



Carpet 1

Base Color: PMS 5209 C
 Accent 1: PMS Cool Gray 1 C
 Accent 2: PMS Cool Gray 3 C
 Accent 3: PMS 7699 C



Carpet 2

Base Color: PMS Black 7 C
 Accent 1: PMS Cool Gray 1 C
 Accent 2: PMS Warm Gray 9 C
 Accent 3: PMS Cool Gray 1 C

Low Traffic Carpet

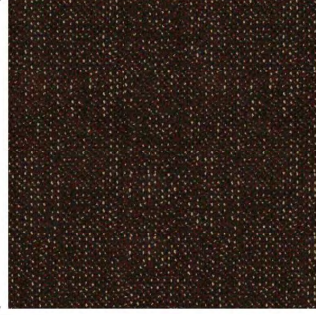

Carpet 3

Base Color: PMS 483 C
 Accent 1:RAL 9003
 Accent 2: RAL 070 85 10
 Accent 3: RAL 7021

Anti-slip Rubber Floor



Rubber 1

Base Color: NCS S8600 B
 Blue Accent: S2030-F500 B
 Beige Accent: S0502-Y50 R
 Grey Accent: S5502-Y

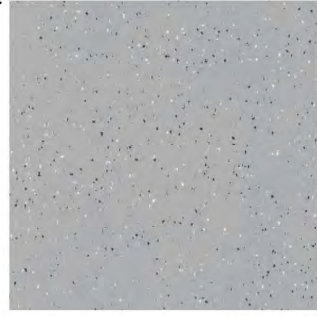

Rubber 2

Base Color: NCS S9000 B
 Blue Accent: S2030-F500 B
 Beige Accent: S0502-Y50 R
 Dark Accent: S5502 Y

Location		Flooring Type
Standard Coach	Aisle	High Traffic Carpet 1
	Under Seats	High Traffic Carpet 1
	Entrance Areas	Anti-Slip Rubber Floor 1
Premium Accessible Coach	Aisle	High Traffic Carpet 1
	Under Seats	High Traffic Carpet 1
	Entrance Areas	Anti-Slip Rubber Floor 1
Café	Aisle	Anti-Slip Rubber Floor 1
	Under Seats (booths)	Anti-Slip Rubber Floor 1
	Entrance Areas	Anti-Slip Rubber Floor 1
	Behind counter	Anti-Slip Rubber Floor 2
	Queuing area	Anti-Slip Rubber Floor 2
	Aisle by Galley	Anti-Slip Rubber Floor 1
Diner	Seated Area	High Traffic Carpet 2
	Kitchen	Anti-Slip Rubber Floor 2
Diner / Lounge	Entrance Areas	Anti-Slip Rubber Floor 1
	Seated Area	High Traffic Carpet 2
Sleeper Cars	Entrance Areas	Anti-Slip Rubber Floor 1
	Aisle/Hallway	High Traffic Carpet 2
	Inside Bedrooms	Low Traffic Carpet 3
Communal Restrooms	Bedroom Restrooms	Anti-Slip Rubber Floor 2
	ATR & STR & Shower	Anti-Slip Rubber Floor 2
Utility Car (Option)	Entrance Areas	Anti-Slip Rubber Floor 1
	Aisle/Hallway	High Traffic Carpet 2
	Common Area	Anti-Slip Rubber Floor 1
	Checked Bag Storage	Anti-Slip Rubber Floor 2
High Capacity Coach (Option)	Aisle	High Traffic Carpet 1
	Under Seats	High Traffic Carpet 1
	Entrance Areas	Anti-Slip Rubber Floor 1

FLOORING MAP

COACH CARS

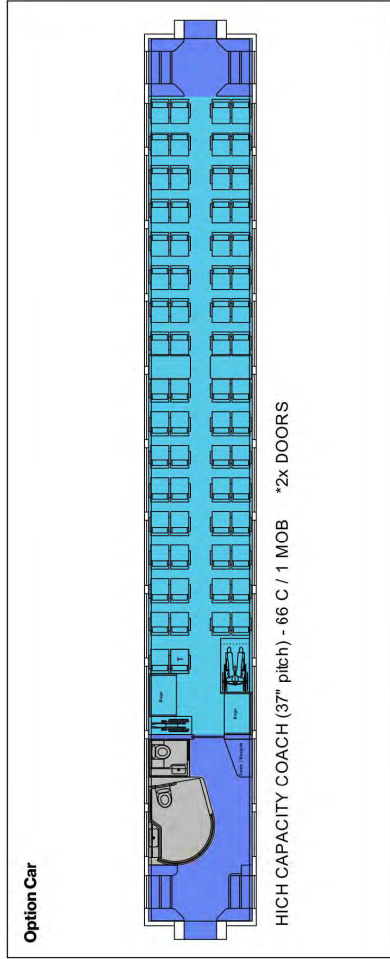
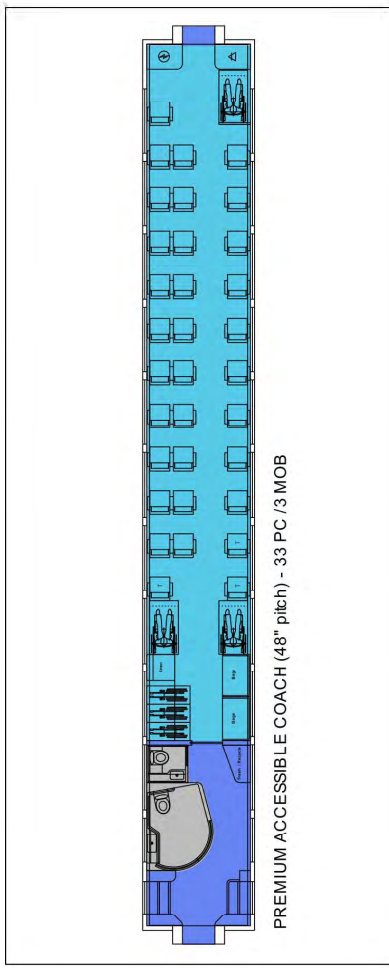
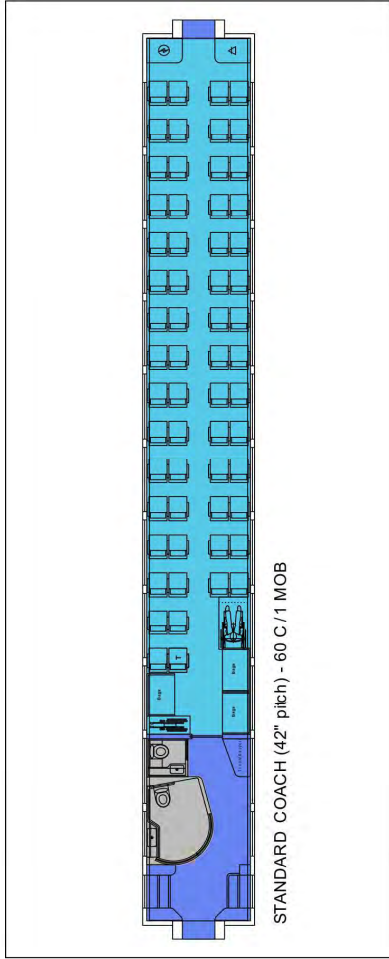
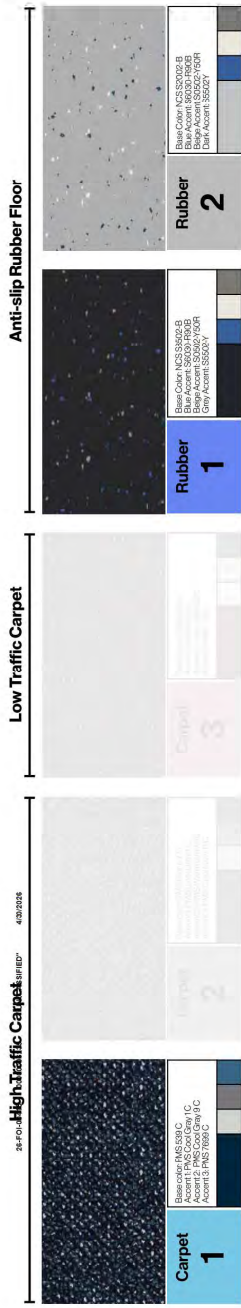

FLOORING MAP

NON-REVENUE CARS

<p>261701 - High Traffic CarpetSM / 100'</p>  <p>Carpet 1</p>	<p>450204</p>  <p>Carpet 2</p> <p>Account: PMS Carpet / TC Account: PMS Alarm Gray / TC Account: PMS Alarm Gray / TC</p>	<p>Low Traffic Carpet</p>  <p>Carpet 3</p> <p>Account: PMS Carpet / TC Account: PMS Alarm Gray / TC Account: PMS Alarm Gray / TC</p>	<p>Anti-slip Rubber Floor</p>  <p>Rubber 1</p> <p>Blue Color: 1525321508 Blue Color: 1525321508 Blue Color: 1525321508 Blue Color: 1525321508 Blue Color: 1525321508 Blue Color: 1525321508 Blue Color: 1525321508 Blue Color: 1525321508</p>	 <p>Rubber 2</p> <p>Blue Color: 1525321508 Blue Color: 1525321508 Blue Color: 1525321508 Blue Color: 1525321508 Blue Color: 1525321508 Blue Color: 1525321508 Blue Color: 1525321508 Blue Color: 1525321508</p>
---	--	---	--	---

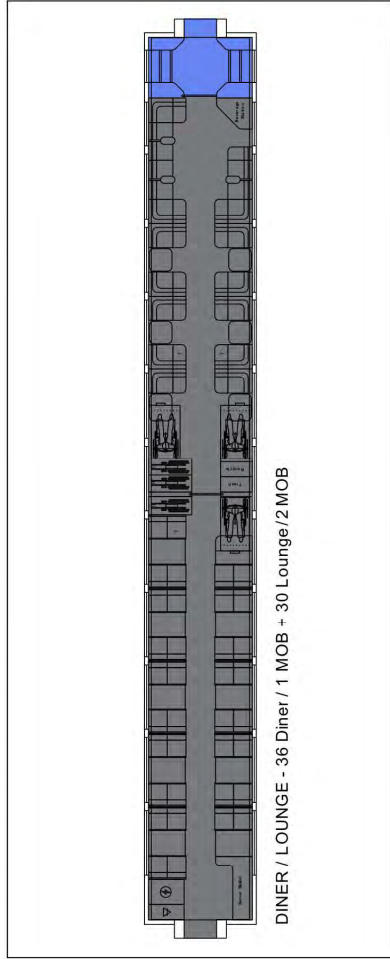
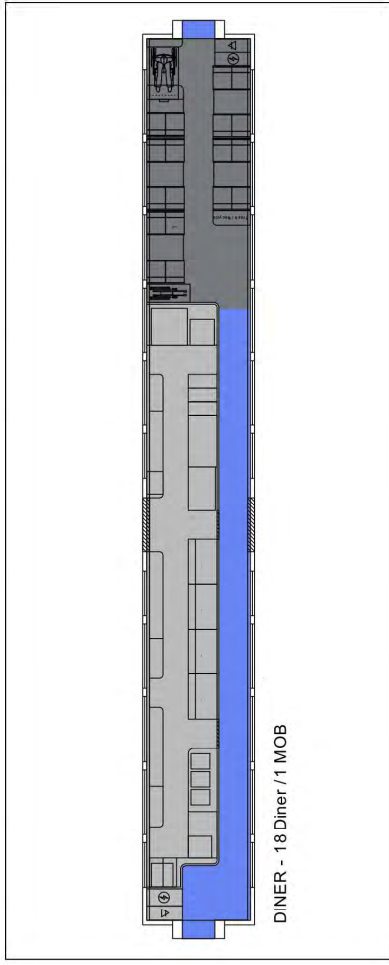
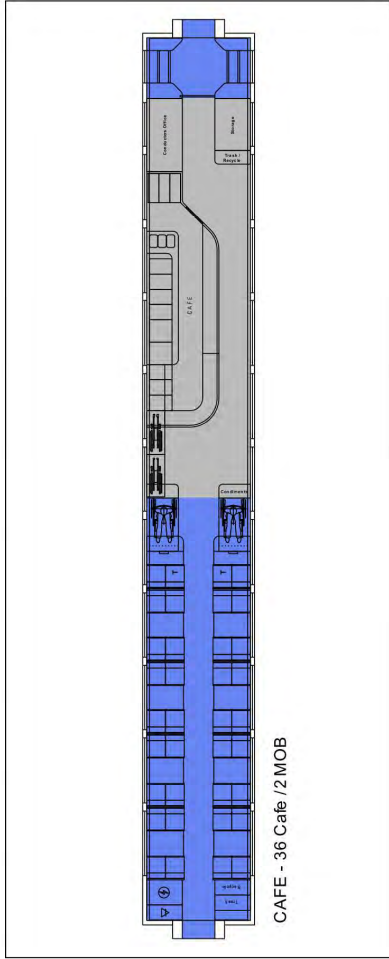

FLOORING MAP

SLEEPER CARS

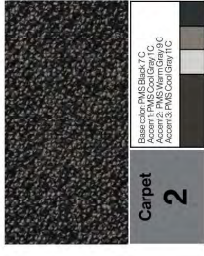
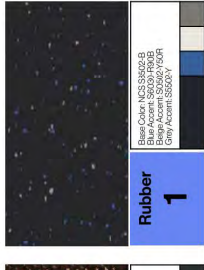
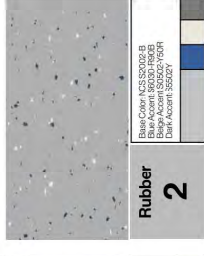
<p>254701 - High Traffic CarpetSM 111011</p>  <p>Carpet 1</p>	<p>450204</p>  <p>Carpet 2</p>	<p>Low Traffic Carpet</p>  <p>Carpet 3</p>	<p>Anti-slip Rubber Floor</p>  <p>Rubber 1</p>	<p>Anti-slip Rubber Floor</p>  <p>Rubber 2</p>
---	--	---	---	--

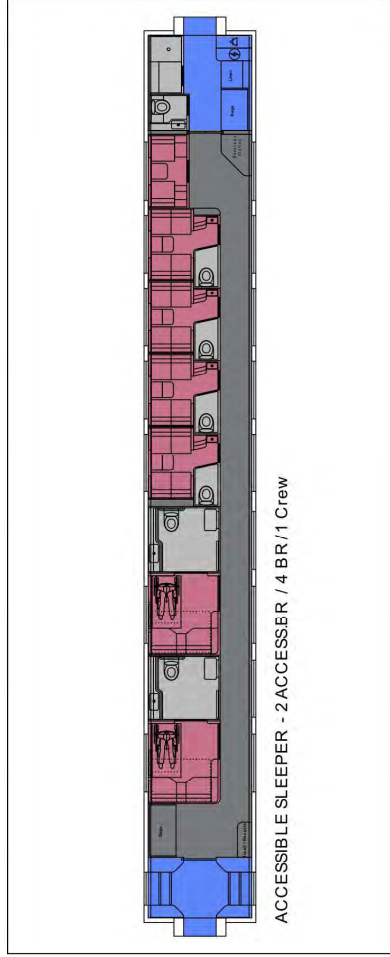

ACCESSIBLE SLEEPER - 2 ACCESSER / 4 BR / 1 Crew

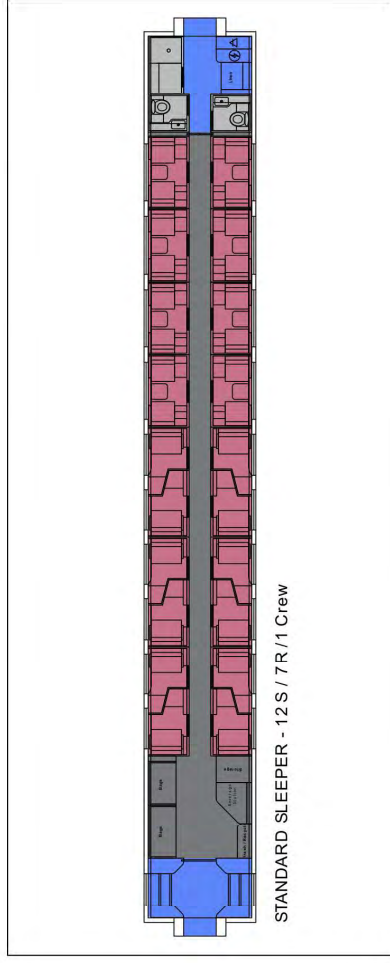

STANDARD SLEEPER - 12 S / 7 R / 1 Crew

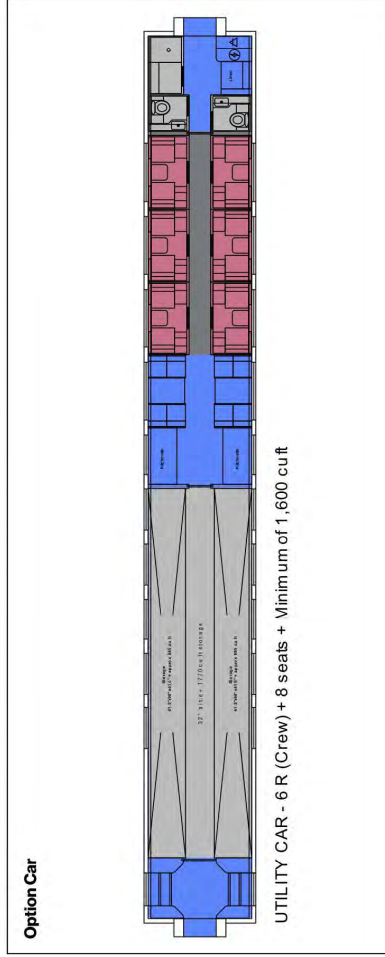

Option Car

UTILITY CAR - 6 R (Crew) + 8 seats + Minimum of 1,600 cuft

STANDARD COACH SEAT



24F010416 000000225

PREMIUM ACCESSIBLE COACH SEAT



24L453110 000000225



SPECIFIC | STANDARD COACH SEAT

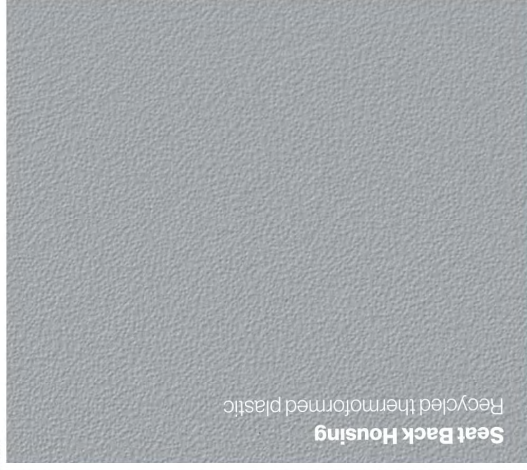
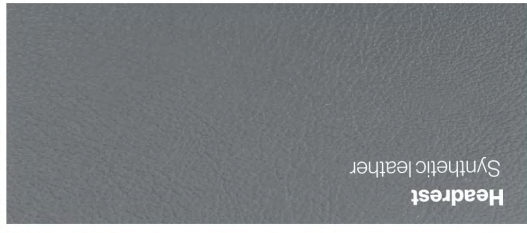
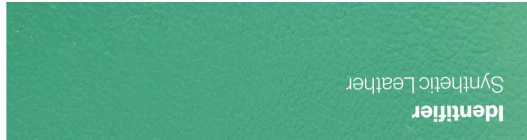

2527010416 0000000225 UNCLASIFIED 430724

COMMON | COACH + PREMIUM SEAT



SPECIFIC | PREMIUM ACCESSIBLE COACH SEAT

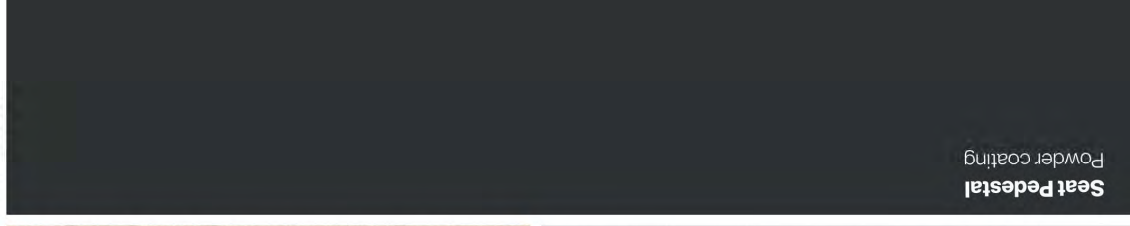
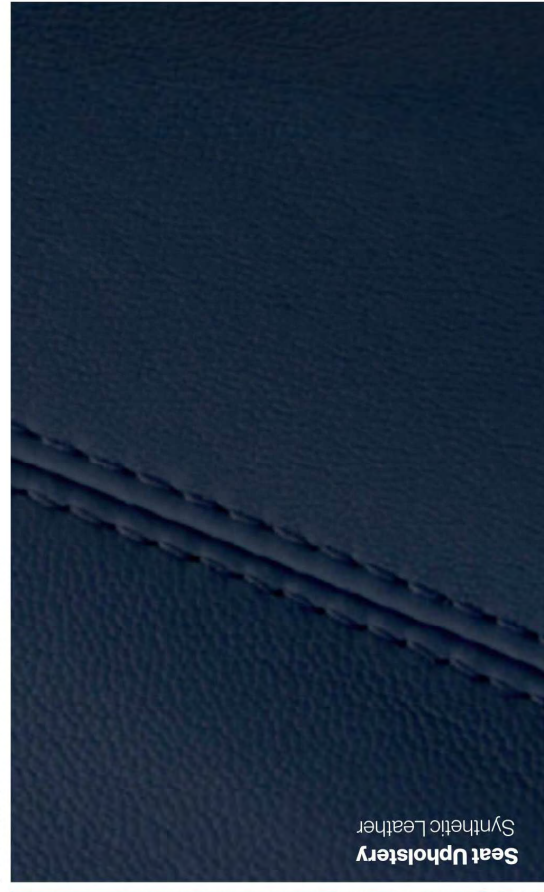
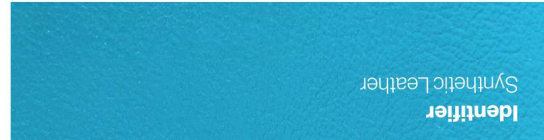

COACH INTERIOR STRUCTURE | FLOOR, SIDEWALLS, CEILING, BULKHEADS, PARTITION DOOR BULKHEADS, PARTITION LIFT BULKHEADS, LUGGAGE RACK + STACK



COACH INTERIOR STRUCTURE | FLOOR, SIDEWALLS, CEILING, BULKHEADS, PARTITION DOOR BULKHEADS, PARTITION LIFT BULKHEADS, LUGGAGE RACK + STACK



Primary flooring
Woven Carpet

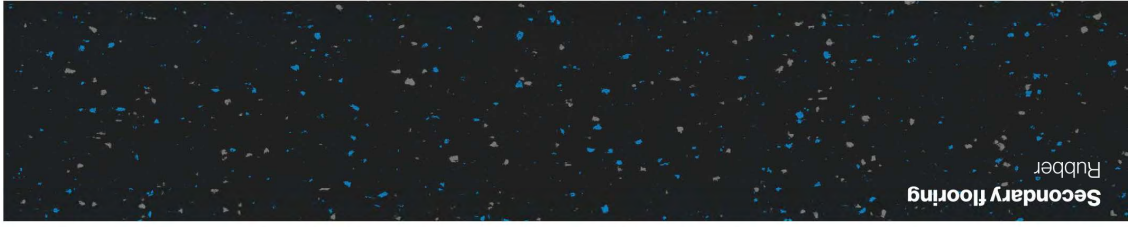

Secondary flooring
Rubber



Lower side wall + Bulkhead
HPL wood veneer



Ceiling panels
HPL / Powder coated



Metal trims
Stainless steel



Racks + Stacks
Glass + Film



Side walls
HPL / Powder coated

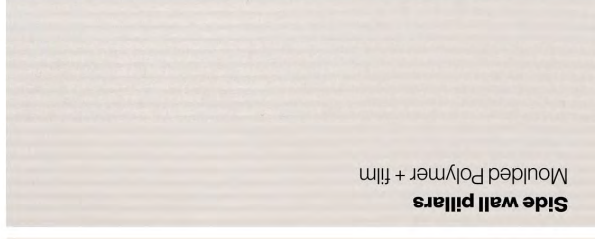

Side wall pillars
Moulded Polymer + film



Metal Trim
Anodized Aluminum

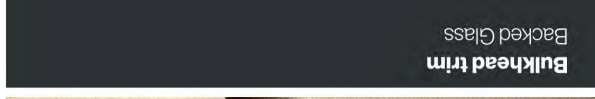

Bulkhead trim
Backed Glass

ROOMETTE / CLUB BEDROOM / ACCESSIBLE BEDROOM / SOLOSUITE

2527010415 0000000225 "UNCLASSIFIED" 4307024



ROOMETTE



CLUB BEDROOM



ACCESSIBLE BEDROOM



SOLOSUITE



CLUB BEDROOM



ACCESSIBLE BEDROOM

COMMON | ROOMETTE / CLUB BEDROOM / ACCESSIBLE BEDROOM / SOLO SUITE

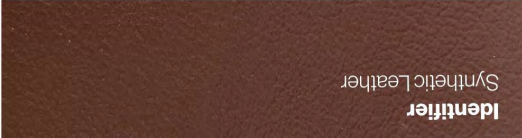

Identifier
Synthetic Leather



Seat Upholstery
Synthetic Leather



Headrest
Synthetic leather

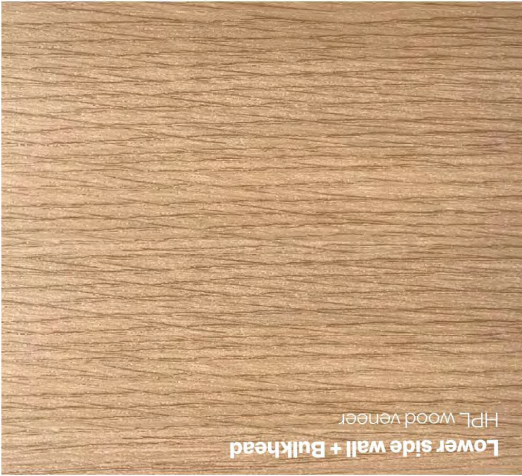

Lower side wall + Bulkhead
HPL wood veneer



Highlight / Cupboard
HPL



Wall surface
Ribbed HPL

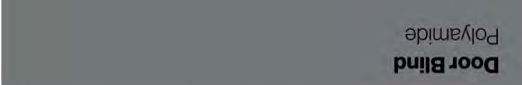

Door Blind
Polyamide



Steps
Rubber

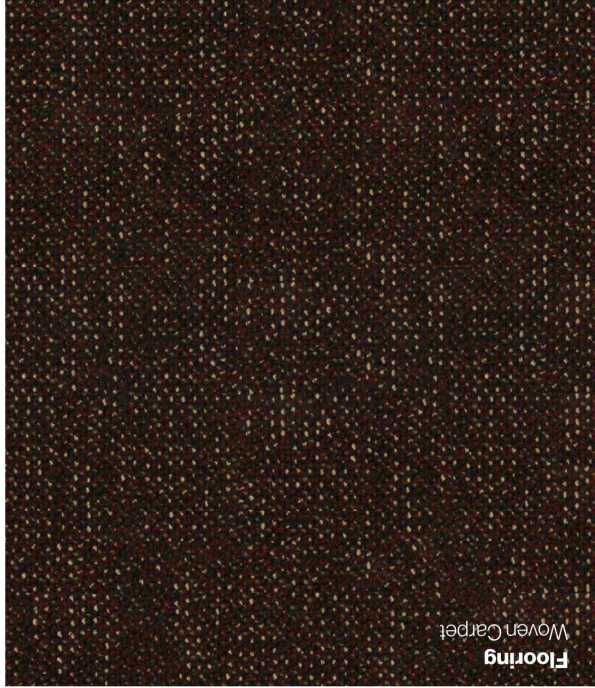

Flooring
Woven Carpet

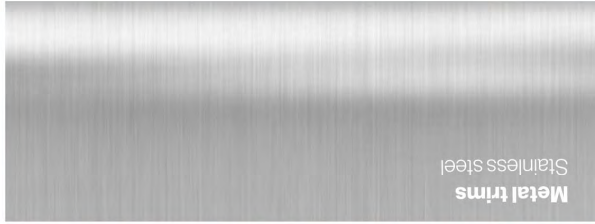

Metal trims
Stainless steel

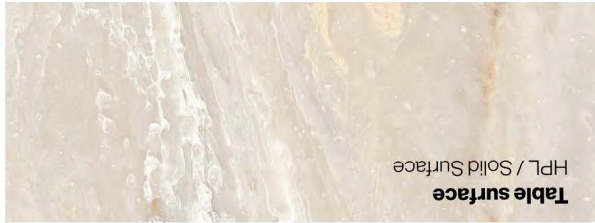

Table surface
HPL / Solid Surface



Side walls
HPL / Powder coated



Ceiling panels
HPL / Powder coated



Metal Trim
Anodized Aluminum



Sink + Surround
Solid Surface

4302024

UNICLASSIFIED

UNICLASSIFIED

CAFE + DINER SEAT / LOUNGE SEAT

252FO10415 000000223 UNCLASIFIED 430724



COMMON | CAFE + DINER SEAT / LOUNGE SEAT



Structure
HPL Oak Veneer



Metal trims
Fossil free Steel



Dividers
Fluted glass



Table surface
HPL / Solid Surface

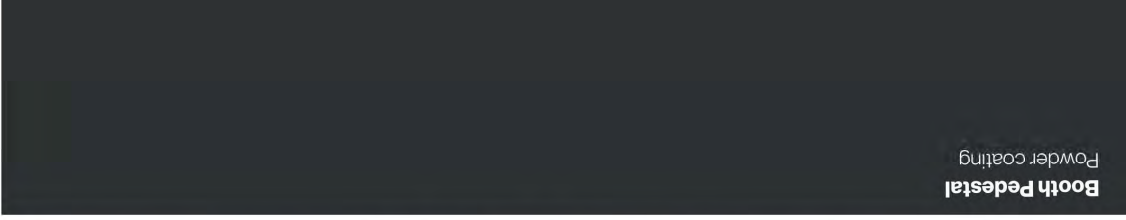

Booth Pedestal
Powder coating

SPECIFIC | CAFE + DINER SEAT



Seat Pad Upholstery
Synthetic Leather

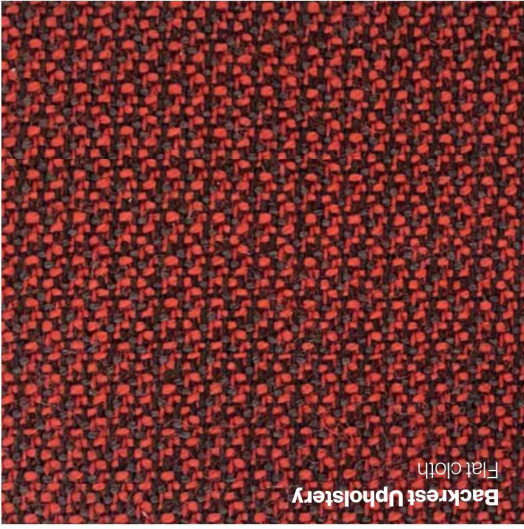

Backrest Upholstery
Flat cloth



Table Lamp
Anodized Aluminum

2527010416 0000000228 4302026

SPECIFIC | LOUNGE SEAT

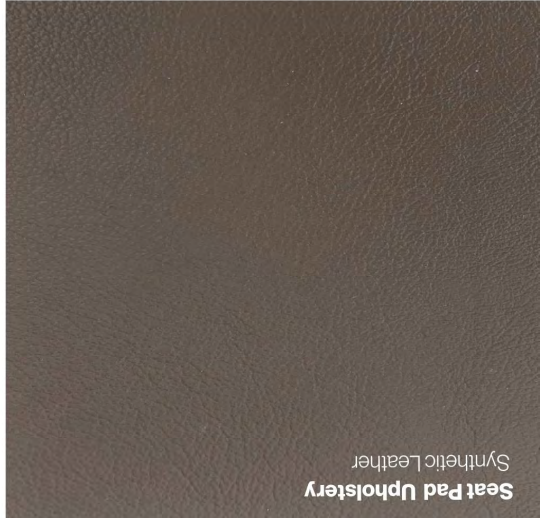

Seat Pad Upholstery
Synthetic Leather

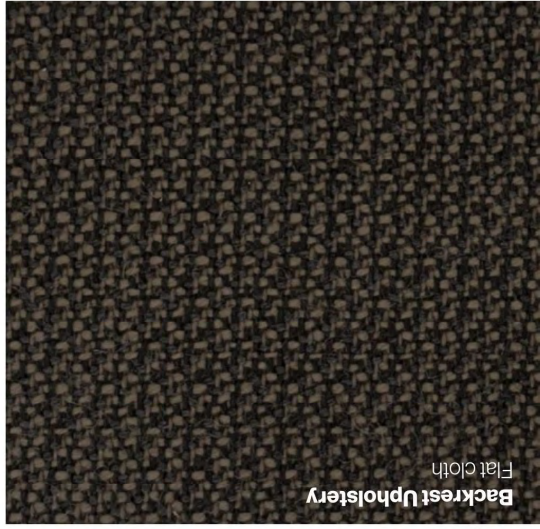

Backrest Upholstery
Flat cloth



Wall Lamp
Anodized Aluminum

COACH CAFE + DINER + LOUNGE STRUCTURE

2527010415 0000002235



CAFE

UNCLASIFIED



COMMON | COACH CAFE + DINER + LOUNGE STRUCTURE / CAFE

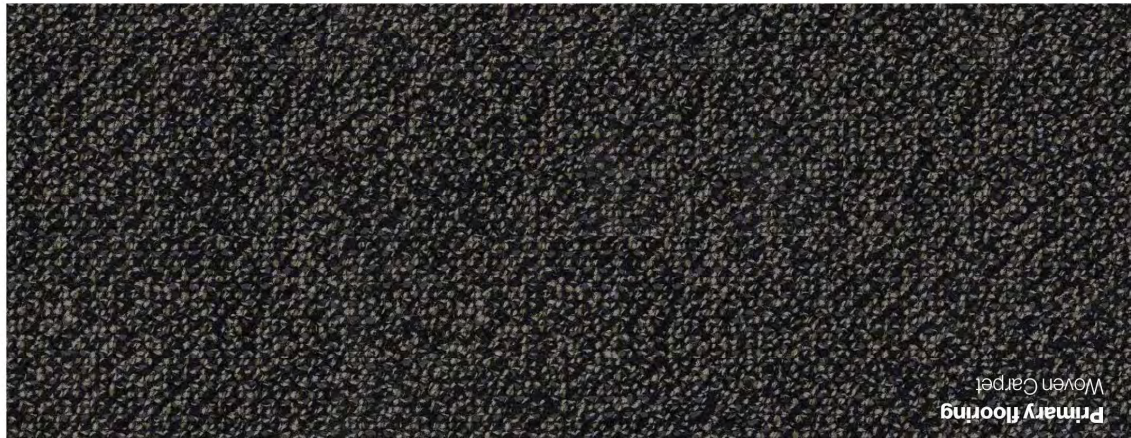

Primary flooring
Woven Carpet

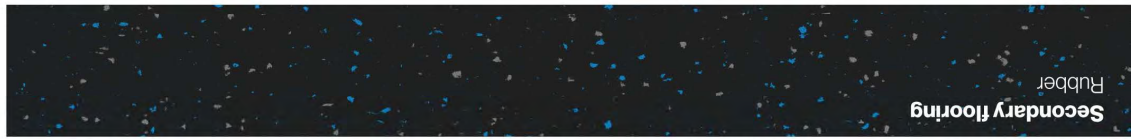

Secondary flooring
Rubber

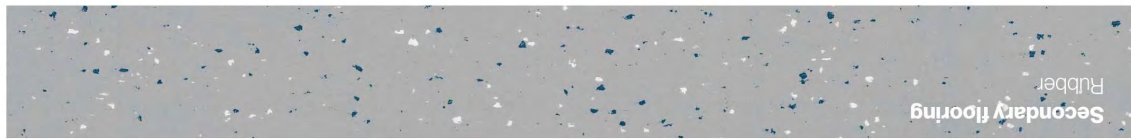

Secondary flooring
Rubber



Ceiling panels
HPL / Powder coated

25470104115 00000002235 UNCLASIFIED 4307024

SPECIFIC | CAFE



Wall + Shelf Paneling
HPL wood veneer

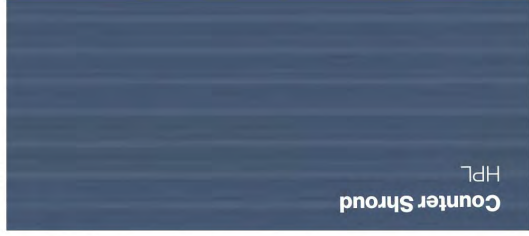

Counter Shroud
HPL



Side walls
HPL / Powder coated

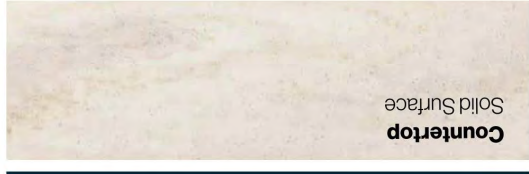

Countertop
Solid Surface

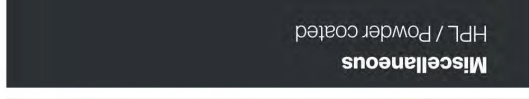

Miscellaneous
HPL / Powder coated



Metal trims
Stainless steel

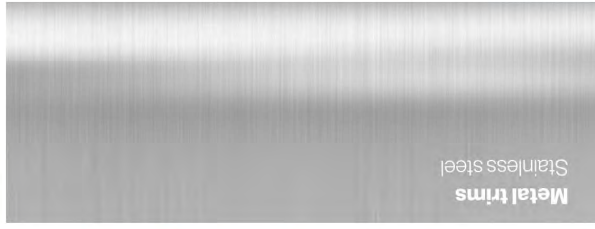

Side walls
HPL / Powder coated



Lower side wall + Bulkhead
HPL wood veneer

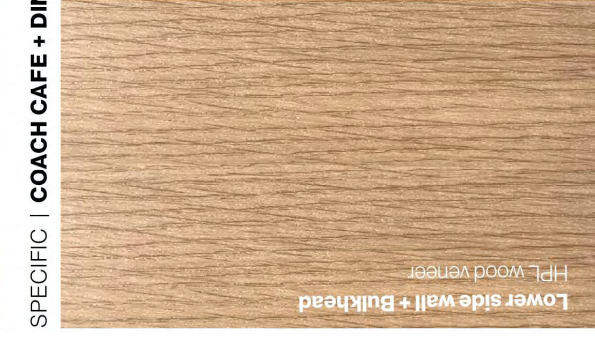

Metal Trim
Anodized Aluminum



Side wall pillars
Moulded Polymer + film



Blind
Polyamide

SPECIFIC | COACH CAFE + DINER + LOUNGE STRUCTURE

UNIFIED TOILET & SHOWER



252FO10416 0000004235 "UNCLASSIFIED" 4/20/2016



COMMON | UNIFIED TOILET & SHOWER

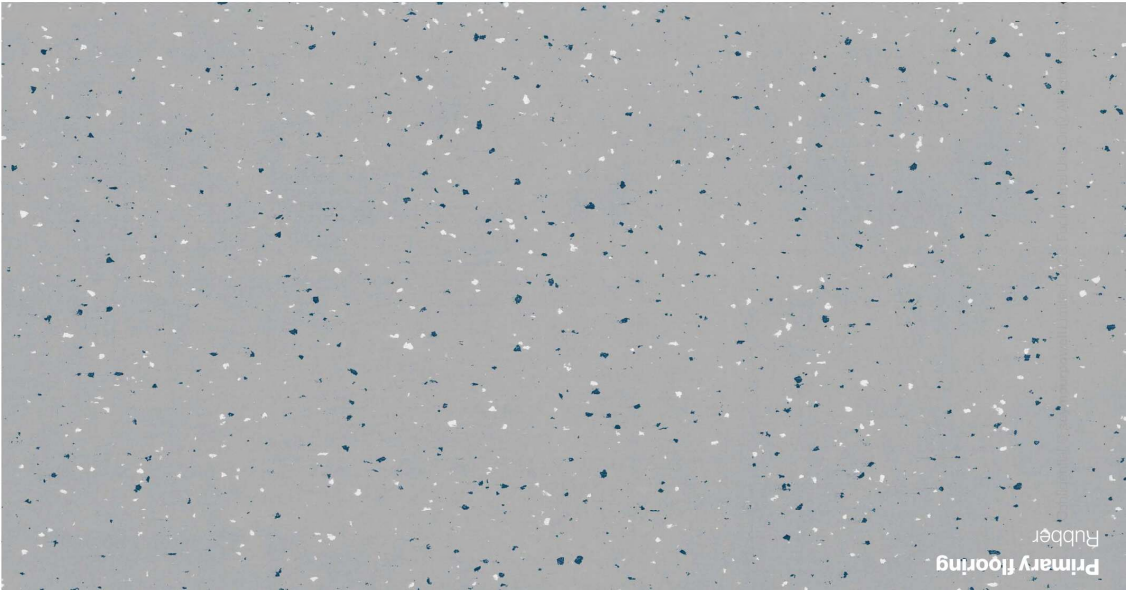

Primary flooring
Rubber



Grab rails + Metal trims
Stainless steel

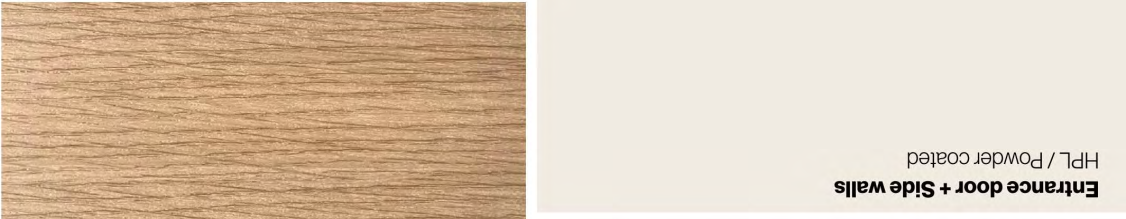

Entrance door + Side walls
HPL / Powder coated



Wall surface
Ribbed HPL



Lower side wall
Moulded polymer



Mirror
Polycarbonate Safety Mirror



Ceiling panels
HPL / Powder coated



Back splash
Moulded polymer or solid surface



Vanity trims
Powder coated or similar

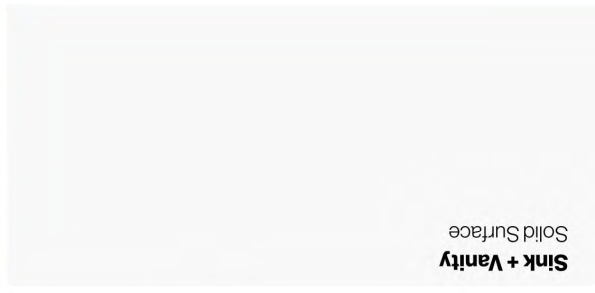

Sink + Vanity
Solid Surface

25270104115 00000002235 UNICLASSIFIED 4207024

UNIFIED COMMON USE AREAS



252F010416 0000000225 "UNCLASSIFIED" 4/20/2016



COMMON | UNIFIED COMMON USE AREAS



Primary flooring
Woven Carpet



Staircase flooring
Rubber



Sleepers flooring
Rubber



Grab rails + Metal trims
Stainless steel



Side walls
HPL / Powder coated



Door
Powder coated or similar



Wall surface
Ribbed HPL



Upper side wall
HPL wood veneer



Ceiling panels
HPL / Powder coated

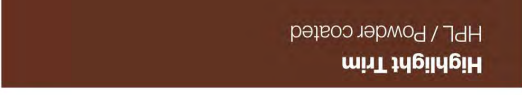

Highlight Trim
HPL / Powder coated

2527010416 0000002225 "UNCLASIFIED" 4307024

Vending Counter
Solid Surface



AMTRAK
AMTRAK
AMTRAK

Thank you.



AMTRAK | AMTRAK | AMTRAK | AMTRAK

Long Distance **CX Vision - Part 1**

Issued March 2026

CONTENTS

PART 1

PROLOGUE

1. The Opportunity
2. The Long Distance Experience
3. Our People

DESIGN DNA

4. Design DNA
5. Feeling Freedom
6. Values

EXAMPLE LAYOUTS

7. Example Car Types
8. Example Consist

PART 2

PRODUCT VISION

9. Accessible path
10. Coach
11. Premium Coach
12. Roomette
13. Club Bedroom
14. Solo Suite
15. Accessible Bedroom
16. Diner
17. Lounge
18. Cafe
19. Toilets and Showers
20. Crew Quarters



2010-01-14 11:00:00 AM

AMTRAK

4/20/14

Prologue

Design DNA

Example Layouts

Product Vision

Prologue

Amtrak® Long Distance CX Vision

THE OPPORTUNITY

Amtrak has a strong legacy as the proud national rail carrier with a mission to connect people across America.

Designing the future of Amtrak's Long Distance trains is a once in a generation opportunity to transform the service into an accessible, sustainable and futureproofed experience that will last another 50 years. This document sets out the Customer Experience Vision for life onboard our future trains.



THE LONG DISTANCE EXPERIENCE

To ride on a long distance Amtrak train is to have an experience like no other.



As we traverse diverse landscapes, our service is designed to cater to passengers of varied abilities and backgrounds. Embracing the eclectic nature woven into the fabric of America, the long distance service unites communities, turning each journey into a seamless and enriching experience.

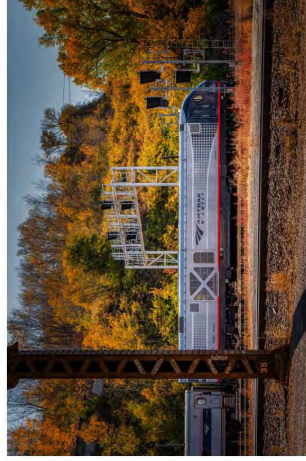

The Amtrak Long Distance Train experience is earthy and grounded with customers traveling through the landscape not above it. Passengers are able to see America in ways that they have never seen before.



Amtrak's crew are the heroes and heroines of our service. They do a fantastic job of providing a high standard of customer service and support the passenger at every step of their journey.

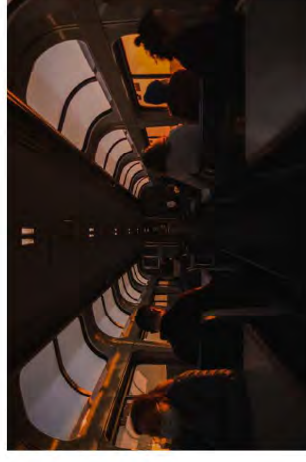

Our unique service demands distinctive spaces. On extended routes, our diners and cafes deliver culinary excellence. In our observation cars, panoramic views become more than just scenery — they become opportunities to connect with fellow travelers, transforming every moment into a destination in itself.

OUR PEOPLE

At Amtrak, our commitment to excellence extends beyond the tracks; it's woven into the fabric of our culture and the hearts of our people. To embark on a journey with us is to embrace the unique tapestry of experiences and needs that define our onboard crew, the dedicated individuals who ensure the seamless operation of our long-distance services.

Understanding our people goes beyond a surface-level exploration—it's about immersing oneself in their daily lives, gaining insight into the challenges and triumphs they encounter on their journeys. We invite those who work with us to delve into the distinct needs of our staff, forging a connection that goes beyond professional collaboration.

This journey of understanding extends to our engineering team, where comprehension of operational intricacies, maintenance requirements and the collaborative efforts of cleaning crews is paramount. To truly contribute to the Amtrak legacy, a comprehensive grasp of these facets is essential.

Our brand is more than a logo; it's a promise: a commitment to delivering exceptional experiences. Those who collaborate with us must engage with our branding, product development, and design teams to ensure that every touchpoint resonates with the core values that define Amtrak.

Inclusivity is at the heart of our services, and our Accessibility Office stands as a testament to this commitment. Collaborators are encouraged to comprehend and address the diverse needs of all travelers, irrespective of their abilities. By working closely with our Accessibility Office, a more inclusive and accessible future for rail travel can be forged.

Finally, innovation propels us forward. Those working with Amtrak must navigate the intricate processes of testing and validation. From user testing to focus groups, utilizing mockups, and embracing cutting-edge technology like collaborative virtual reality—innovation is the vehicle through which we drive progress.

In essence, to work with Amtrak is to embark on a journey of understanding, collaboration, and innovation—a commitment to shaping the future of rail travel by embracing the richness of our people, the heart and soul of Amtrak. Welcome aboard.

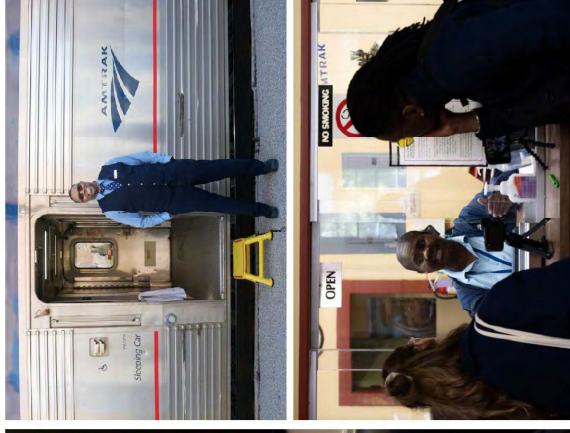



REVOLVING ROSSBETH UNCLERBED 42024

Prologue

Design DNA

Example Layouts

Product Vision

Amtrak® Long Distance CX Vision

Design DNA

DESIGN DNA

Amtrak's Long Distance design DNA has been created to inspire outstanding developments as we design the future long distance rail fleet.

The Design DNA brings to life how the Amtrak long-distance brand personality can be translated into a distinctive rail experience. It is created from a deep understanding of our passenger and crew's needs across the varied products we'll offer onboard. This will create a higher level of emotional engagement between our passengers, crew and our brand.

What is DNA Model?

A Design DNA is a tool that embodies a clear, unequivocal understanding of a brand and how it is expressed through design.

How does the model work?

In the very centre of the DNA model is the Heart. This is the central creative idea that inspires every expression of the brand and captures the distinctive magic of the Amtrak long distance experience. It expresses the feeling that we want our passengers and crew to have whenever they ride our long-distance trains.

Supporting the Heart are four key Values that add direction and colour to how the long distance brand should behave. They are inextricably linked to one another, but can be dialled up or dialled down depending upon their relevance to any design elements onboard the train. Think of them as four individual notes that together create a perfect harmony.. it is possible to amplify one of the notes to make a point, but not without the other two in the background to create the harmony.



HEART

FEELING FREEDOM

Feeling Freedom fills the Heart of our Design DNA.

Our long-distance trains offer all Americans a rare opportunity to escape the burdens of daily life. To be free to explore without the constraints of time. To choose a journey that supports the environment. To be yourself and make new friends.

Whether for a few days revelling in the vast glory of the shifting American landscape, or for a few hours... of simply kicking back and relaxing... Amtrak long distance trains' design empowers people to discover our Land of Liberty on their own terms.

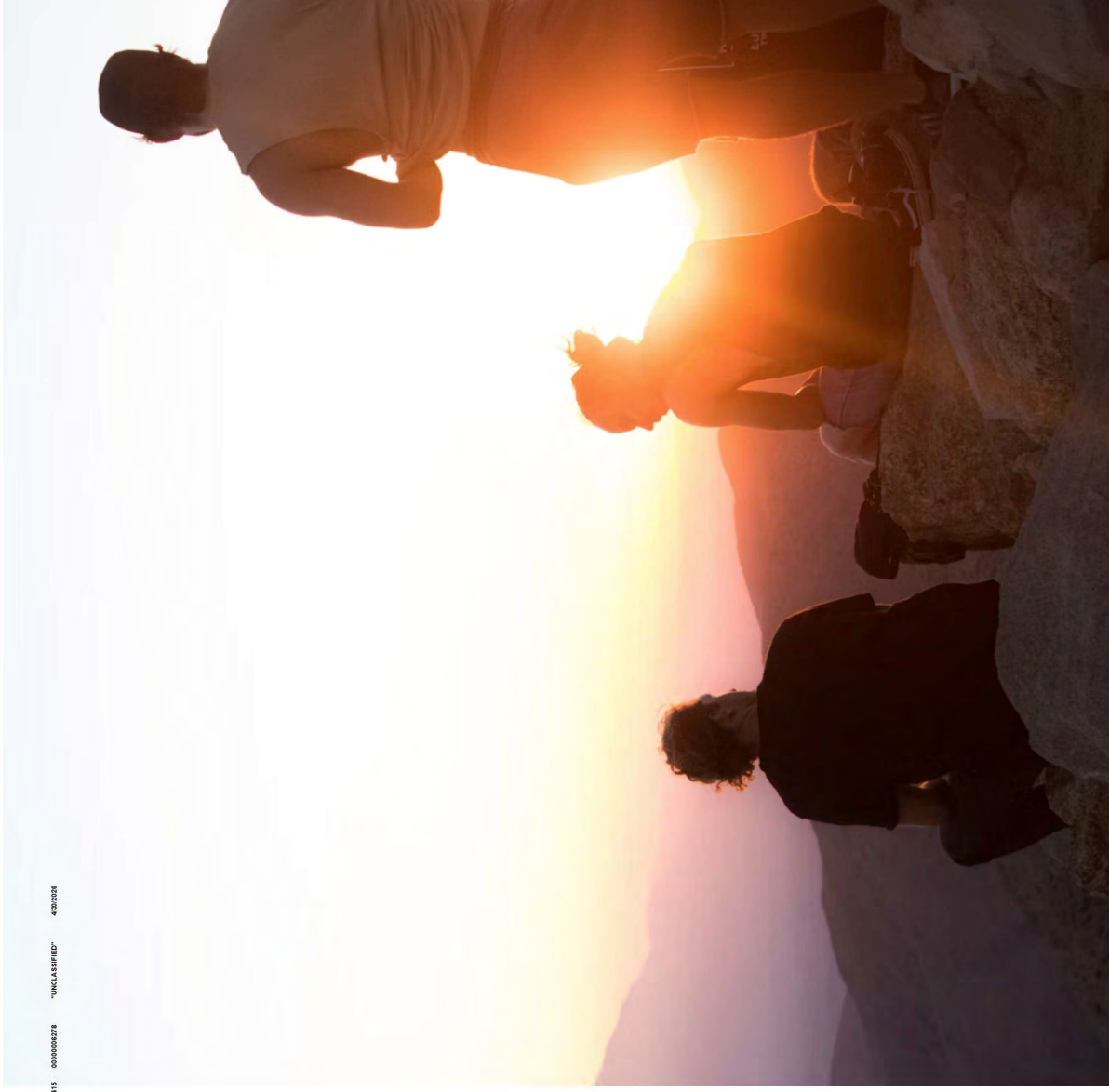



VALUE 01

AMERICAN ICONIC

American Iconic celebrates the Amtrak Long Distance Trains as a destination wholly in themselves.

It inspires us to imbue our vehicles with the optimistic spirit of American design, creating enduring meaning and value so that the memories made on board last a lifetime. It reminds us of the history of the rails we ride and challenges us to question the archetypes of the past, so that we pioneer better long-distance experiences for the future.

American Iconic asks us to make good design available to all, by exploring the notions of ease and comfort. It encourages us to focus on the essential, so that each part is necessary and contributing to the whole. It challenges us to be brave, to shoot for an iconicity that can inspire a new generation to choose 'the best way to travel'.



VALUE 02

HOME TO ALL

Amtrak long distance trains provide common ground. We create empathetic interiors that allow all Americans, no matter their ability, to ride with equal dignity and grace.

Our long distance trains create dynamic communities. To support these communities we consider the social function of our spaces, allowing privacy and peace where it's needed - and conviviality where it is desired.

This approach encourages the serendipitous moments of connection that add joy to our on board experience. Whether passengers or crew, all are supported by our desire to travel with comfort and ease. Come on in!



VALUE 03

WILDERNESS WITHIN

Whether it's a private view from a roomette or a shared experience from coach, our Long Distance trains offer passengers a seat at one of the greatest shows on earth; the American landscape.

Wilderness Within reflects the awe that is kindled when seeing the American landscape gently slip by from dawn through to dusk. We find beauty in both the remarkable and the mundane moments, in the outskirts of cities and the rhythms of small town life. In the vastness of the Plains and the expansive Pacific Coast. In the low lying shadows of canyons and high treelined mountains.

We honour these landscapes by echoing their beauty onboard, and cherish them by taking a sustainable approach to design that ensures we do our bit to preserve and protect it for tomorrow.



VALUE 04

READY FOR TOMORROW

Ready for Tomorrow represents our commitment to face the difficulties of tomorrow with grit and grace.

No matter the freezing lows of winter or the scorching highs of summer, we anticipate tomorrow so we can move forward with unwavering purpose.

Solid, safe and reassuring in challenging times, we build resilience into our rolling stock through adaptability. Designing our trains around pragmatic, robust and coherent systems that can be evolved over time.

STANDARD COACH

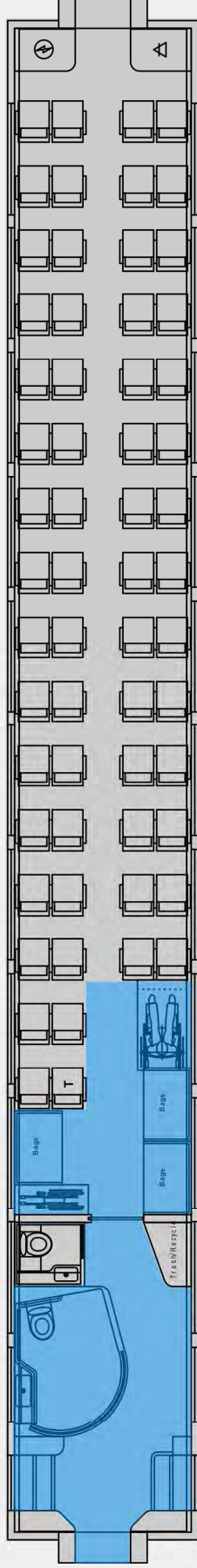

STANDARD COACH

60 High Capacity Coach Seats @ 42" pitch

1 Mobility Position

1 Accessible Restroom

1 Standard Restroom

Loading doors at one end

PREMIUM ACCESSIBLE COACH

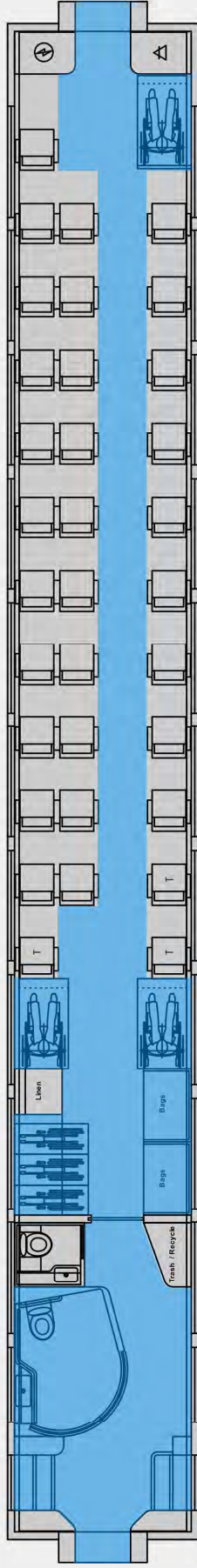

PREMIUM ACCESSIBLE COACH

- 33** High Capacity Coach Seats @ 48" pitch
 - 3** Mobility Position
 - 1** Accessible Restroom
 - 1** Standard Restroom
- Loading doors at one end

HIGH CAPACITY COACH

*OPTION

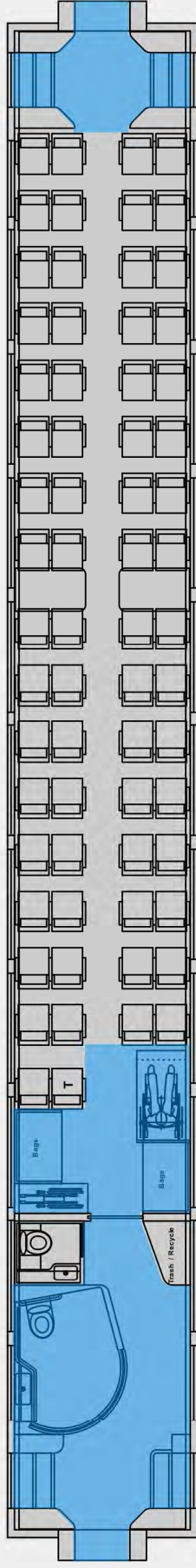

HIGH CAPACITY COACH COACH

- 66** High Capacity Coach Seats @ 37" pitch
 - 1** Mobility Position
 - 1** Accessible Restroom
 - 1** Standard Restroom
- Loading doors at each end

CAFÉ

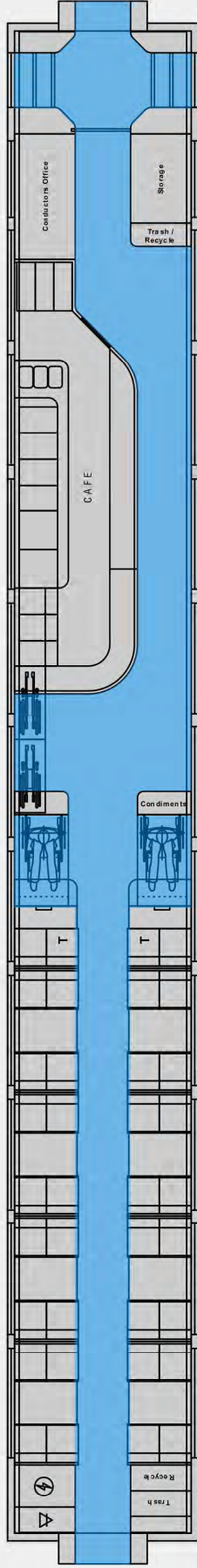

CAFÉ

- 36** Café Seats
 - 2** Mobility Position
 - 1** Conductors Office
- Loading doors at one end

DINER

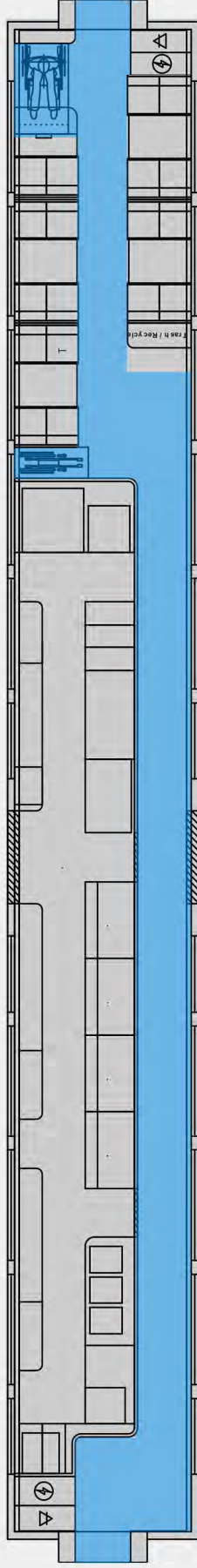

DINER

18 Diner Seats

1 Mobility Position

Central loading doors

DINER / LOUNGE

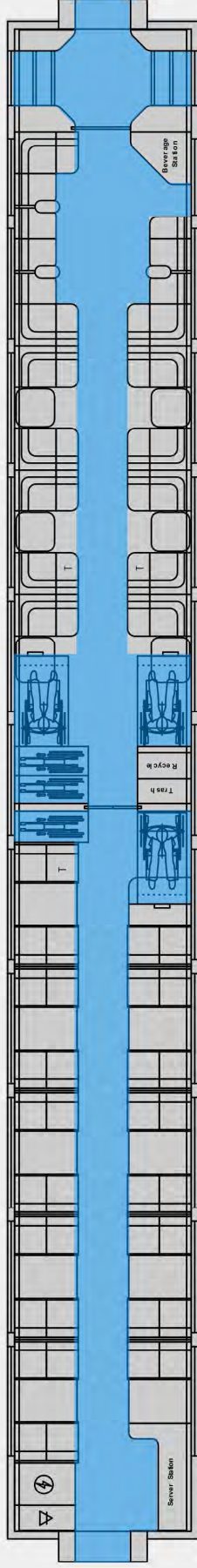

DINER / LOUNGE

- 36** Diner Seats
 - 1** Diner Mobility Position
 - 1** Server Station
 - 30** Lounge Seats
 - 2** Lounge Mobility Position
- Loading doors at one end

ACCESSIBLE SLEEPER

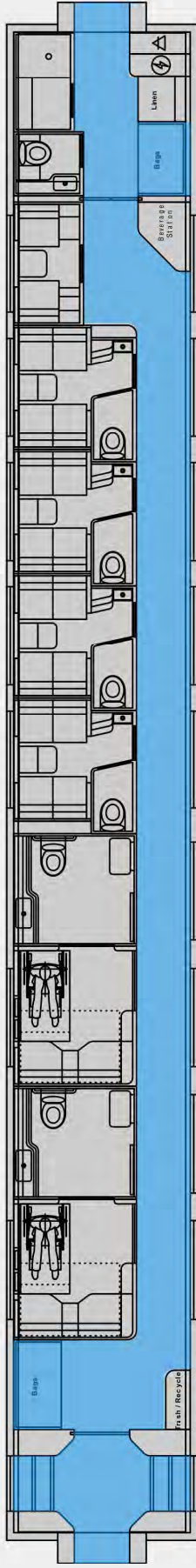

ACCESSIBLE SLEEPER

- 2** Accessible Bedrooms
 - 4** Standard Bedrooms
 - 1** Crew Bedroom
 - 1** Standard Restroom
 - 1** Communal Shower
- Loading doors at one end

STANDARD SLEEPER

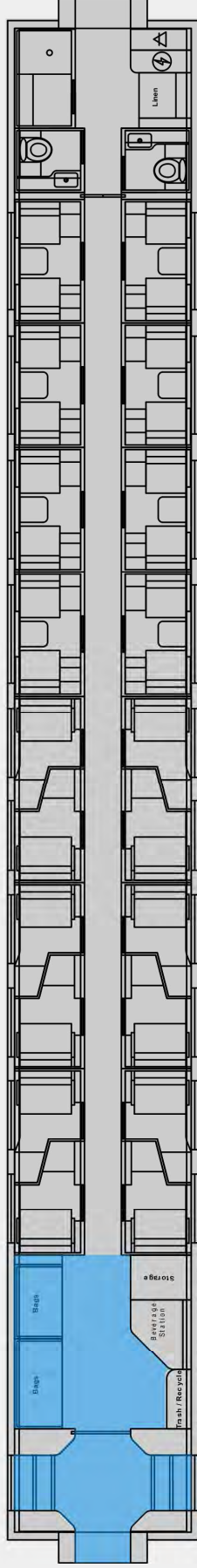

STANDARD SLEEPER

- 12** Solo Suites
 - 7** Roomettes
 - 1** Crew Bedroom
 - 2** Standard Restroom
 - 1** Communal Shower
- Loading doors at one end

UTILITY CAR

*OPTION

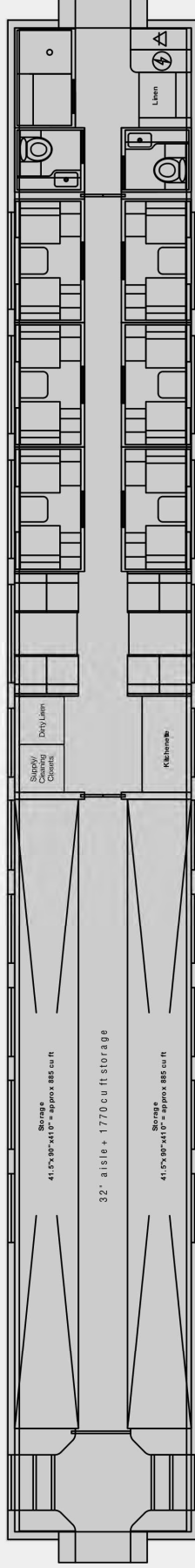

UTILITY CAR

- 6 Crew Bedroom
 - 2 Standard Restroom
 - 1 Communal Shower
 - 8 Cafe Seats
- Loading doors at one end

EXAMPLE CONSIST

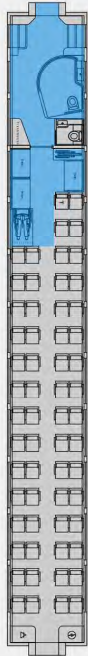

STANDARD COACH (42" pitch) - 60 C / 1 MCB

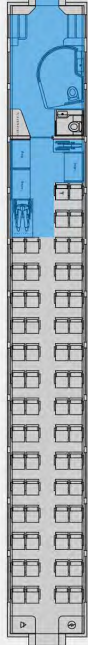

STANDARD COACH (42" pitch) - 60 C / 1 MOB

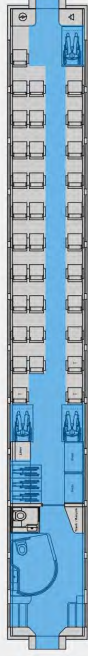

PREMIUM ACCESSIBLE COACH (48" pitch) - 33 PC / 3 MOB

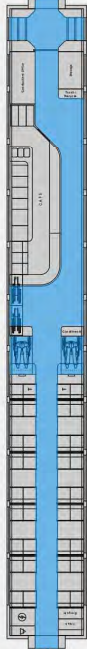

CAFE - 36 C and / 2 MOB

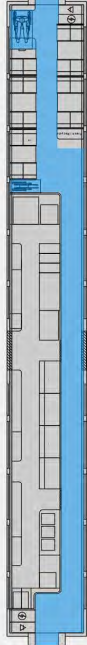

DINER - 18 Diner / 1 MOB



DINER / LOUNGE - 36 Diner / 1 MOB + 30 Lounge / 2 MOB



ACCESSIBLE SLEEPER - 2 ACCESSBR / 4 BR / 1 Crew

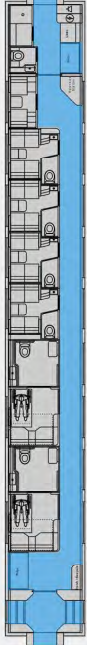

ACCESSIBLE SLEEPER - 2 ACCESSBR / 4 BR / 1 Crew

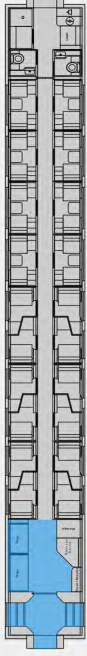

STANDARD SLEEPER - 12 S / 7 R / 1 Crew

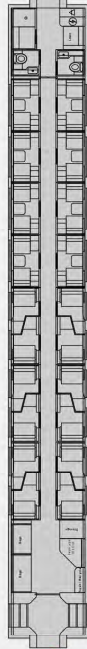

STANDARD SLEEPER - 12 S / 7 R / 1 Crew



UTILITY CAR - 6 R (Crew) - 8 seats + Minimum of 1,600 cu ft

Accessible path in accordance with equivalent facilitation



AMTRAK | AMTRAK.COM | 1-800-AMTRAK

Thank you.



AMTRAK | AMTRAK | AMTRAK | AMTRAK

Long Distance **CX Vision - Part 2**

Issued March 2026

CONTENTS

PART 1

PROLOGUE

1. The Opportunity
2. The Long Distance Experience
3. Our People

DESIGN DNA

4. Design DNA
5. Feeling Freedom
6. Values

EXAMPLE LAYOUTS

7. Example Car Types
8. Example Consist

PART 2

PRODUCT VISION

9. Accessible path
10. Coach
11. Premium Coach
12. Roomette
13. Club Bedroom
14. Solo Suite
15. Accessible Bedroom
16. Diner
17. Lounge
18. Cafe
19. Toilets and Showers
20. Crew Quarters



REPORTS 80008277 UNCLASSIFIED #2024

Prologue

Design DNA

Example Layouts

Product Vision

Product Vision

Amtrak® Long Distance CX Vision



25-FD-04118

0000004271

"UNCLASSIFIED"

20-0228



ACCESSIBLE PATH

A warm welcome for all

Our new train design prioritizes accessibility. An accessible path runs from coach through the Cafe, Diner and Lounge to Private Rooms.

ACCESSIBLE PATH

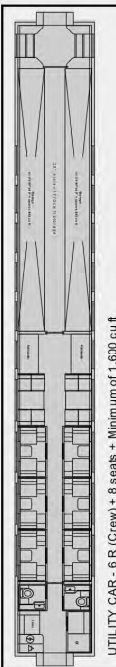
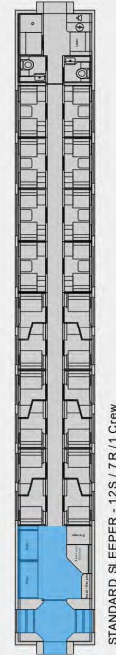
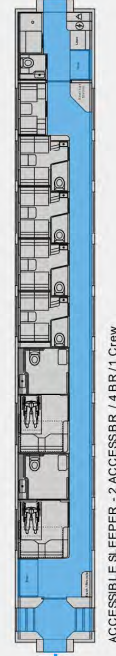
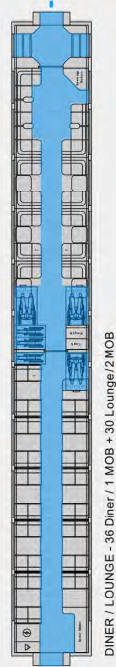
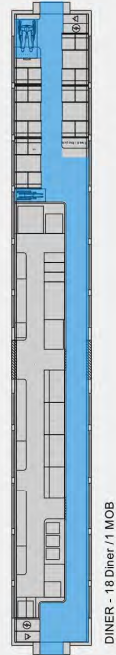
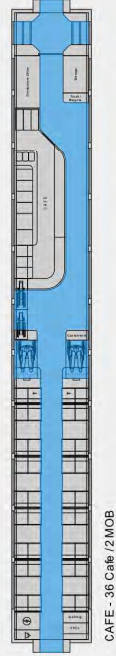
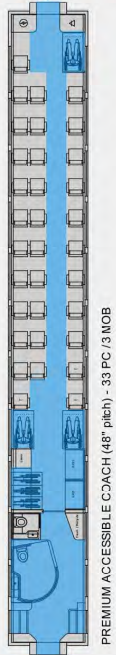
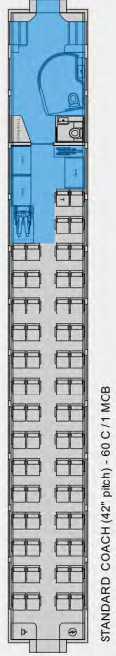

Option Car

ACCESSIBLE CORE

The accessible core offers an accessible path at 32" wide that allows passengers who use wheelchairs to move freely between each car.

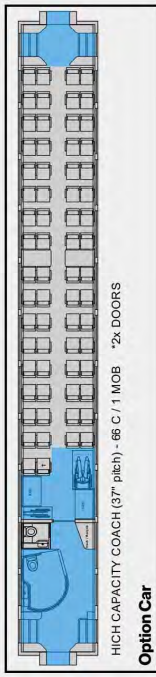

Option Car

Accessible path in accordance with equivalent facilitation

ENTRANCE WAYS

Our new trains extend a warm welcome to all passengers. Handholds are strategically placed to enhance stability as passengers move through the car and access their accommodations. The interior design is crafted to feel more like a hotel lobby, featuring a central light, wood finishes, and an open layout.



SEAMLESS ACCESS

The vestibule is designed as an open and intuitive space. Soft corners and carefully crafted architecture guide natural passenger movement, supporting safe and efficient flow even at busy times. Seamless surfaces maintain visual clarity and simplify cleaning and maintenance. Carefully selected colors and materials introduce gentle contrast to enhance openness and aid navigation for visually impaired passengers. Vertical and horizontal handrails are integrated throughout, providing reassurance, accessibility, and support from the moment passengers step on board.



SLEEPER HALLWAYS

Sleeper hallways are bright and open, with simple way-finding and clear room numbering. Each sleeper car also features a well-appointed beverage station offering coffee and fresh water.



CX VISION | SLEEPER HALLWAYS

25-FD-00416 000000271

"UNCLASSIFIED"

4/20/2024



TRAVEL EASE

Amtrak's commitment to thoughtful baggage handling ensures your bags are well cared for throughout the journey. Baggage towers, checked baggage cars, and convenient overhead shelves allow passengers to travel knowing their belongings are safely stored and easily accessible.





COACH

The Heart of Our Journey

Our coach passengers are the heart of Amtrak's long-distance service. They are the driving force behind our mission to connect people across America. Their choice to ride with us fuels the journey that brings our nation closer together. We understand the importance of offering an

affordable travel option while ensuring that our coach customers feel valued and appreciated.

The interior should be thoughtfully designed to reflect the significance of this market and should echo the value we place on their experience.



25-FD-04118

0000000271

"UNCLASSIFIED"

4/20/2024



OPTIMIZED FOR SLEEP

Experience the ultimate sleep-friendly coach seat: plush cushions, tailored ergonomics, a recline optimized for rest, privacy wings, an adjustable headrest pillow, and a leg rest for added comfort. Designed to help passengers sleep well and wake refreshed.



25-F010416 0000004271 UNCLASSIFIED 4/20/24



CX VISION | COACH

24 NOT RESERVED
25 NOT RESERVED
ON BOARD TRAIN

25-FOURTEEN 0000004271 "UNCLASSIFIED"

NEXT STATION:
GLENVIEW

15:18
MILEAGE
0
11:20



VISUALLY RESTFUL

Seats and surrounding architecture are designed to provide maximum functionality and convenience without visual clutter. By balancing integrated features with a purity of form, the space feels calm, visually restful, and comfortable for passengers. Elegance and convenience are thoughtfully combined throughout.



25-FD-0416 000004271 "UNCLASSIFIED" 4/20/2016



FULLY EQUIPPED

Comfy seats with tables for your laptop, device holders, cup holders for your favorite beverages, a fully adjustable seat for relaxation, power sockets to keep your devices charged, and personal lighting for the perfect ambiance. Everything you need for a comfortable and effortless journey.



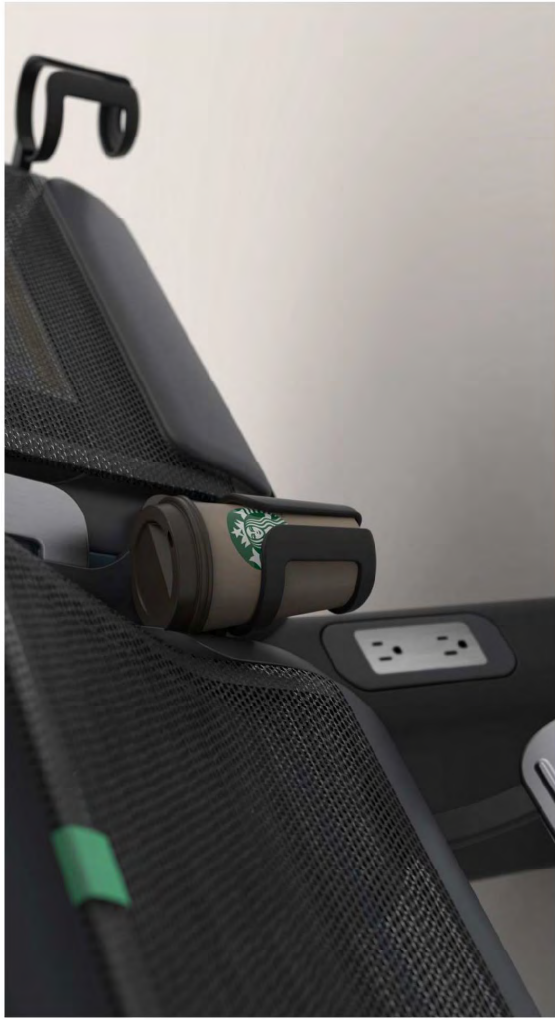



PREMIUM COACH

Elevating the Long-Distance Coach Experience

In response to the demand for elevated comfort on our long-distance trains, we proudly introduce 'Premium Coach.' Our customers are at the forefront of a new era in Amtrak's long-distance service. 'Premium Coach' represents an exciting step forward, designed to elevate our passengers' journey with spacious, larger seats, more space,

fantastic views, and enhanced privacy. With 'Premium Coach,' our customers can expect the same fantastic features as in our standard coach, but with the added luxury of enhanced seating and increased space. Together, we embark on this journey, redefining long-distance travel with 'Premium Coach'.



25-F01-04115

©2025 Amtrak
PHOTOGRAPHY



CX VISION PREMIUM COACH

RF7010416 000004271 "UNCLASSIFIED" 4/20/2016

GREENVIEW

TRANQUIL SPACE

Premium Coach features a generous seat pitch that increases legroom and personal space. The 2 x 1 seating configuration allows for wider seats and a more comfortable passenger experience. Large headrest wings add privacy and support.





CX VISION | PREMIUM COACH

CRADLE COMFORT

Premium Coach seats recline to the renowned "Lazy Z" position, designed to enhance comfort. This ergonomic recline supports a more relaxed sitting and sleeping posture, making long journeys more comfortable for passengers.



CX VISION | PREMIUM COACH

2527010416 0000004271 "UNCLASIFIED" 4/20/2024



CX VISION | PREMIUM COACH

25-FD-0416 000004271 "UNCLASSIFIED" 4/20/2016



FULLY EQUIPPED

The Premium Coach seat offers a high level of personalization, with an adjustable center console table and "Lazy Z" recline providing fully customizable seating positions. Practical features include a device holder, cup holders, USB, and power outlets for added comfort and convenience.





THE LAZY Z

The "Lazy Z" position is designed to enhance comfort during long periods of sitting. In this position, the seat reclines to support the upper body while raising the knees, reducing pressure on the lower back and undersides of the legs. The result is a more ergonomic and comfortable posture for extended travel.



25-FD-00416 000000271

"UNCLASSIFIED"

© 2015



ROOMETTE

Setting the New Standard for a Classic Format

Introducing our revamped Roomettes for the new generation of long-distance travel. These classic accommodations have received a modern makeover, seamlessly blending the timeless comfort of leather seats with a contemporary aesthetic. As you step inside, you'll

discover a private space designed for relaxation and rest, complete with the familiar format you know and love. Our upgraded Roomettes redefine the art of travel, providing an elevated experience that marries classic charm with a fresh, sophisticated style.

25-F01-0416 000004271 "UNCLASSIFIED" 4/20/2016



| ROOMETTE



2547010416 0000004271 "UNCLASSIFIED" 4/20/2018

HOME FROM HOME

Each space is designed to feel like a true home away from home. A carefully curated palette of inviting, high-quality materials such as wood, metal, and leather creates a warm and approachable tactility. Lighting is thoughtfully balanced to support both function and ambiance, resulting in environments that feel comfortable and enriching for passengers.

26/F010416
UNCLASSIFIED

4307026



BETTER BEDS

The seats are ergonomically designed with a contoured form, side bolsters, lumbar support, and adjustable headrests, optimized for daytime comfort. When converted to a lower berth, they form a fully flat surface for a restful night's sleep. The intuitive conversion allows passengers to easily switch between seating and sleeping configurations. Slide-down upper bunks provide additional accommodation for sharing and families.



25-F01-0416 000004271 "UNCLASSIFIED" 4/20/24



IN ROOM STORAGE

Storage is thoughtfully integrated throughout the rooms, with discreet cabinets keeping the space uncluttered. Dedicated locations for carry-on luggage, including convenient storage beneath the seat, ensure belongings remain easily accessible while maintaining a calm, organised environment.

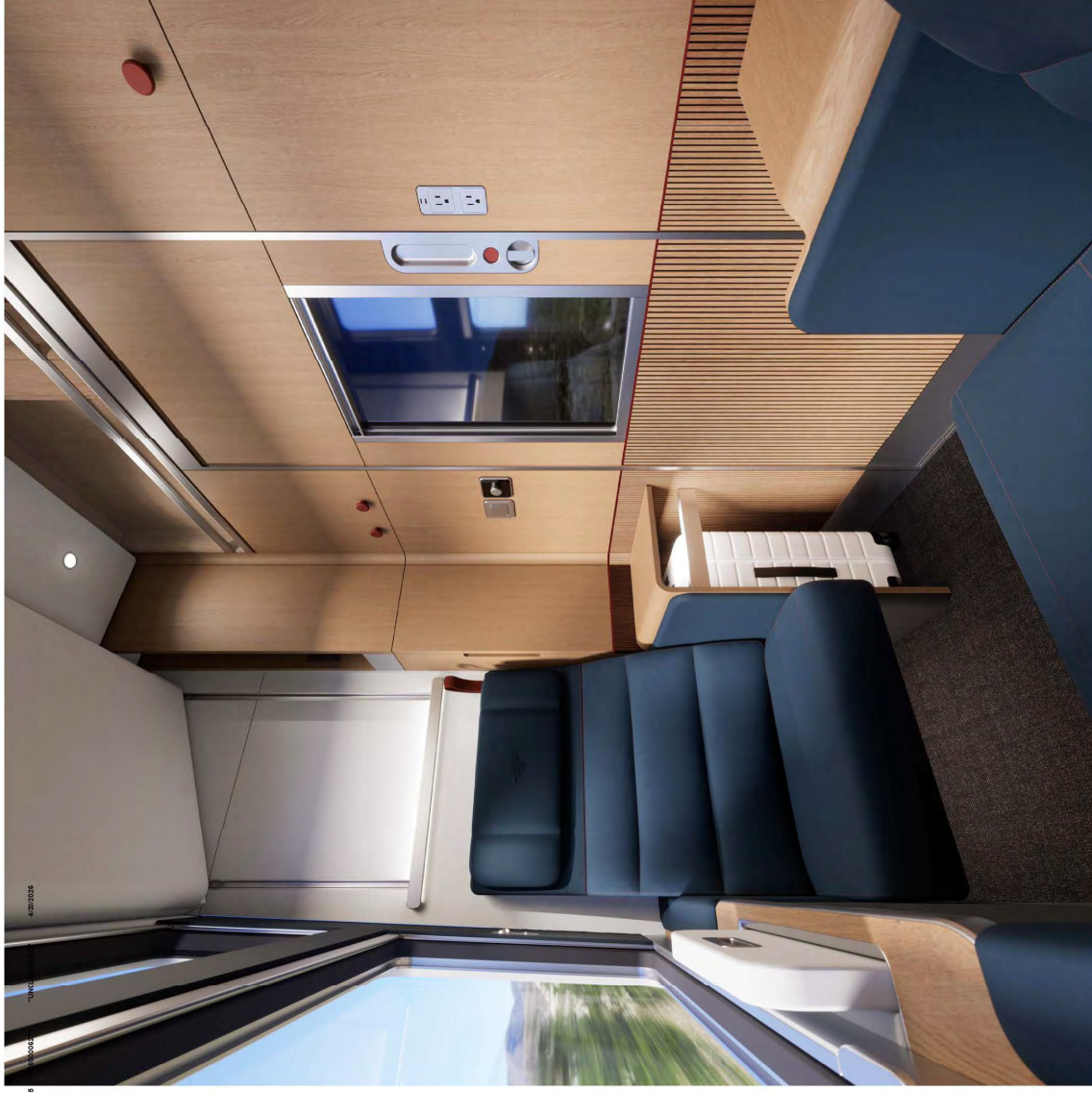

UNCLUTTERED
26-F01-04116
4-20-2024

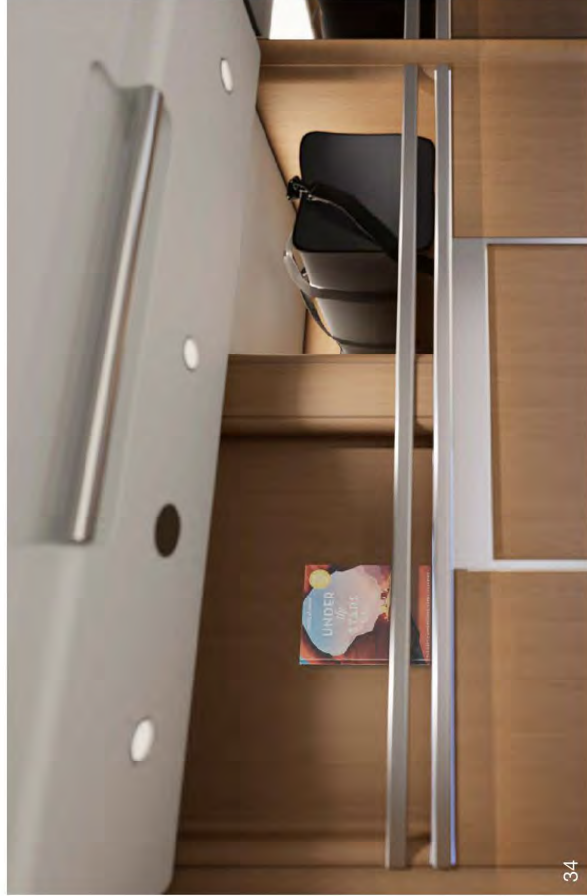



CLUB BEDROOM

Versatility in a New, Spacious Format

The Club Bedroom is a groundbreaking addition to our accommodation options.

This innovative format provides ample room for two passengers but with the added flexibility to comfortably sleep a family of four. With four seats that convert into a double bed and an additional slide down double bunk, the Club Bedroom ensures a restful journey for our customers seeking that little extra space and versatility.

Complete with an en-suite bathroom, vanity sink, and ample storage, this spacious bedroom represents the next level of travel comfort.



25-FD-0418

000004271

"UNCLASSIFIED"

4/20/2018

25-PJ-0416 000004271 "UNCLASSIFIED" 4/20/2016



CONVIVIAL SPACE

The Club Bedroom features two face-to-face sofas, creating a comfortable space for relaxation, conversation, or seating up to four passengers. With a double lower berth and a double upper bunk, it provides generous sleeping arrangements for two or a cozy option for families.



25-FD-10415 000000271 "UNCLASSIFIED" 4/20/24

FEELING COMFORT

Enjoy exceptional comfort with wide seats, carefully designed with ergonomic precision and enhanced by plush cushioning for a supportive, contoured fit. Soft leather upholstery provides a refined finish that elevates the travel experience. Additional features include an extra-large table, multiple power outlets for personal devices, and convenient cup and bottle holders.





UNCLASSIFIED 430024
REF ID: A116 00000000

BETTER BATHROOMS

Our bedrooms feature well-appointed vanity areas, and the Club Bedroom includes a modern en-suite shower and toilet. Vanity units are equipped with mirrors, storage cabinets, and fresh towels. The bathrooms offer modern conveniences such as a large rain shower, separate shower handset, touchless flush, and complimentary shower gel, shampoo, conditioner, and lotion.



26-F010416

000000271

UNCLASSIFIED

4-20224

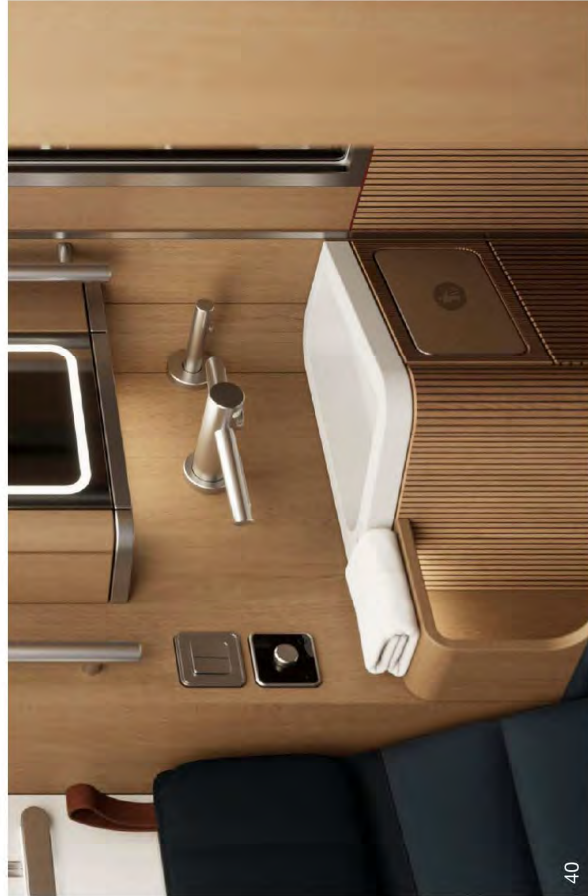

IN ROOM STORAGE

Storage is thoughtfully integrated throughout the room, making intelligent use of vertical height and otherwise unused spaces. Open storage cubbies built into sidewalls and corners provide convenient places for smaller personal items. Dedicated locations for carry-on luggage, including storage above the bathroom and beneath the seat, ensure belongings remain easily accessible.



25-FJ-0415 000004271 UNCLASSIFIED 4/2024



SOLO SUITE

Where Solo Comfort Meets Shared Adventures

Introducing 'SoloSuite,' our versatile accommodation designed to cater to the unique needs of solo travelers, with the flexibility to accommodate two passengers when desired.

'SoloSuite' offers a comfortable solo retreat with a spacious single bed and all the amenities and conveniences you'd expect from our bedrooms. For

those seeking the companionship of a fellow traveler, 'SoloSuite' can be transformed into a premium twin room, ideal for sharing.

With 'SoloSuite,' passengers can enjoy the flexibility to choose between privacy and conviviality, ensuring a tailored travel experience.



26-FD-04119 000000271 "UNCLASSIFIED" 4/20/2018



VISTA VIEWS

The bedrooms are centred around large windows that frame the passing landscape and bring the outside world into the room. The architecture and layout are designed to celebrate these views, keeping them at the heart of the experience. When desired, blinds can be deployed to soften daylight or provide complete privacy.



2547010416 000000271 UNCLASIFIED 4/20/24



FLEXIBLE FORMAT

The room features a spacious seat and bed, with the layout centred on the experience of a single passenger. The design opens up the room's vertical space, creating a bright, airy atmosphere while allowing additional storage above. Dual windows further enhance the sense of light and openness. A central divider can open to connect two Solo Rooms, creating a distinctive suite with a spacious central table for shared activities or meals.

26F010416

500002271 "INFLIGHT" © 2019



CX VISION | SOLOSUITE



25-F01-0416 000004271 "UNCLASSIFIED" 4-20194



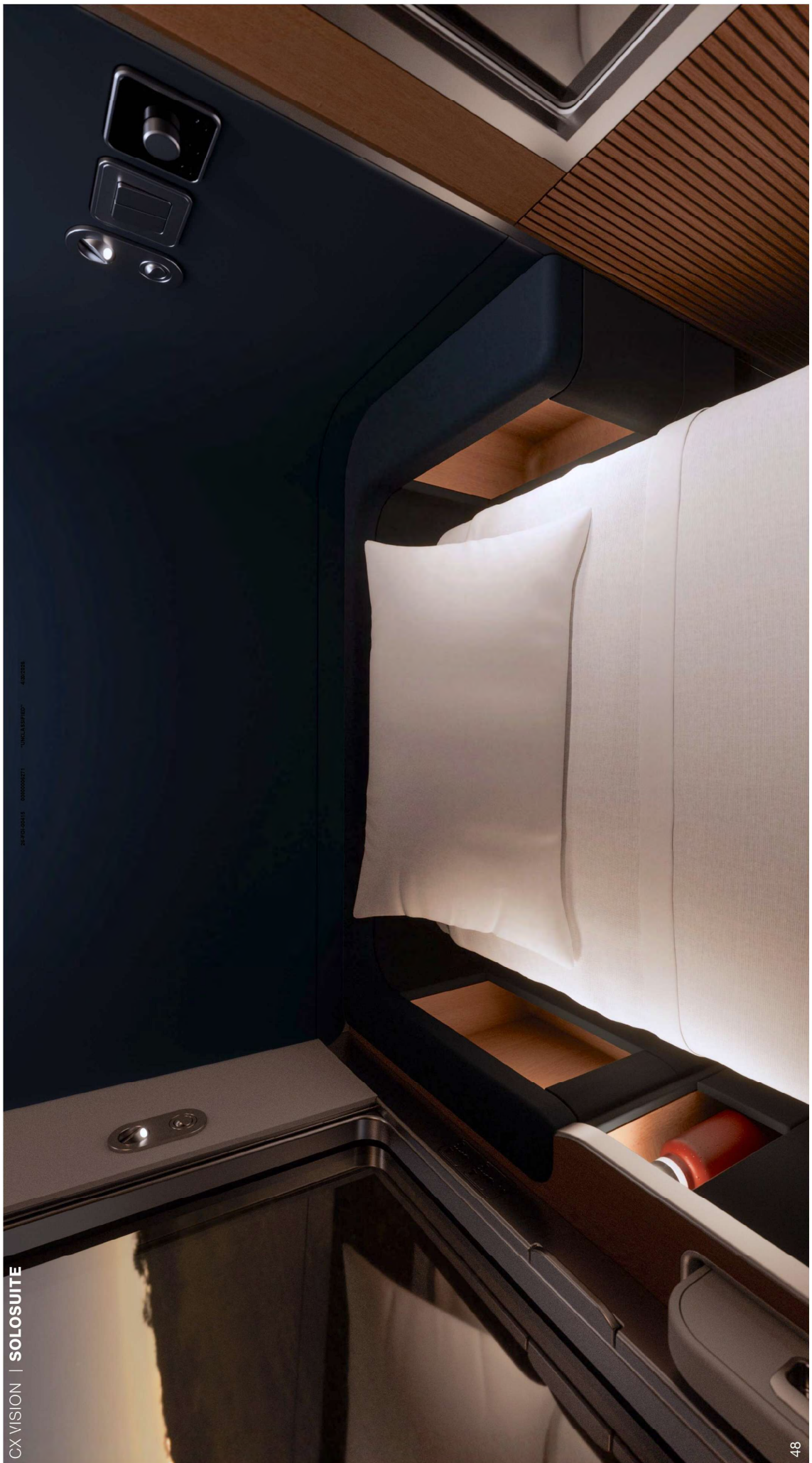

REPOSUITS | 300000077 | "HIGHLIGHTING" | 4/2024



ACCESSIBLE BEDROOM

Comfort without Boundaries

Introducing the 'Accessible Bedroom', a fully inclusive accommodation designed to cater to passengers with diverse mobility needs. This spacious room features two beds, including a lower accessible double berth and an upper bunk, ensuring that everyone can enjoy a comfortable journey. In addition to all the standard amenities, the 'Accessible Bedroom' boasts an en suite accessible bathroom, providing convenience and comfort.

The room offers ample space for passengers who use wheelchairs to easily navigate and access all features, making it a welcoming and inclusive option for a diverse range of travellers.

A room meticulously designed with our passengers' needs in mind, ensuring that mobility and comfort are equally prioritized, resulting in an inclusive and welcoming space.



25-FD-0418

UNCLASSIFIED

430224

CX VISION | ACCESSIBLE BEDROOM

25-F01-0416 0000004271 "UNCLASSIFIED" 4/20/2016





ELEVATED ACCESS

Our accessible room features wide sliding doors with audio and tactile controls for ease of use. Strategically placed handrails and a carefully planned layout maximise accessibility, providing turning space for people who use wheelchairs and ample room for seat and bed transfers. Lighting and blinds are fully accessible, while carefully selected flooring and finishes enhance visibility, creating a safe, functional, and user-friendly environment.





2847010416 0000004271 UNCLASSIFIED 4/20/2018

BETTER BEDS

The beds have been carefully designed for flexibility and ease of use. The upper single berth provides comfort and safe access, with a flexible ladder and integrated handrails to support passengers climbing in and out. The lower double berth offers a spacious, accessible sleeping space that can be used in either orientation, with handrails on three sides and well-placed lighting to ensure confidence and comfort. Together, the arrangement balances accessibility, convenience, and a restful journey.





BESPOKE SOLUTIONS

Our accessible room is designed with flexibility in mind, offering various configurations to meet different needs. A dedicated accessible space by the window ensures passengers who use wheelchairs can enjoy scenic views comfortably. The inclusion of a fold-out seat with an integrated backrest adapts the space to different accessibility requirements, catering to the diverse needs of our passengers and ensuring a space that is suitable for everyone.



REPRODUCED BY UNCLASSIFIED 2000002771

400028

WASH HERE

254-P0100816 - 00000551371 UNCLASSIFIED 4/20/2024



CX VISION | ACCESSIBLE BEDROOM TOILET & SHOWER

RS-FD-0416 000000271 UNCLASIFIED 4/20/2016





26-FD-05118

000000271

"UNCLASSIFIED"

4/20/2018



DINER

Traditional Dining, Timeless Delights

Continuing the tradition of Amtrak dining cars, our new long-distance trains offer the classic format with contemporary flair. Step aboard to savor freshly prepared meals against the backdrop of breathtaking scenery. In our dining cars, you'll embrace a communal spirit, sharing tables and

stories with fellow travelers, making every journey unforgettable. As part of Amtrak's tradition, we provide a unique dining experience that enhances the magic of long-distance travel, turning your meal into a memorable voyage.

ACCESSIBLE FOR ALL

In the Diner, accessibility is paramount, allowing everyone to relax and enjoy its comforts. An accessible pathway, designed to accommodate passengers who use wheelchairs, extends throughout the entire diner car. Handholds on every booth provide stability for passengers as they navigate the car. Handrails seamlessly transition into the glass dividers which enhance the sense of security and privacy.





25-PD100415 0000000271 "UNCLASSIFIED" 4/20/2024



CURATED AMBIANCE

Curated lighting and skylight blinds are used to curate an ambiance that transforms throughout the day, creating an inviting, calm, and sophisticated atmosphere during daylight hours and transitioning seamlessly into an intimate, sumptuously cozy setting in the evening. A captivating and adaptable dining experience designed to kindle feelings of romance and indulgence as passengers dine with us. Our signature table and wall lamps add a touch of restaurant-like charm, ensuring a delightful dining experience tailored to your every need. We are committed to crafting memorable moments during every meal in our Diner car.

A TOUCH OF CLASS

Our dining cars are more than places to enjoy a great meal; they are a destination space that lives at the heart of the journey. The design of the diner on our new long-distance trains respects the heritage of these spaces with refined elegance, evoking a warm and inviting ambiance. Red booth seating symbolizing a first-class service and fostering a sense of warmth and connection. Bold blue accents in the table lamps add a contemporary touch, creating a timeless yet captivating atmosphere. Confident textural lines on seats, dividers, and window pillars break up the space, accentuate the height, and add a sense of grandeur to the interior architecture.



25-F010416 000004271 "UNCLASSIFIED" 4/20/24

CRAFTED MATERIALS

In our Diner, simplicity in form and construction allows us to prioritize premium materials and exceptional build quality. Our solid surface tables feature refined marble finishes, complemented by booth seating wrapped in rich wood veneers. These thoughtful choices not only enhance the ambiance but also ensure durability and comfort, reflecting our dedication to an elevated and dependable dining experience.



25-F010416 000000271 "UNCLASSIFIED" 4/20/24

DESIGNED FOR SERVICE

The Diner is designed to support efficient, premium at-seat service. A wide aisle allows crew to move easily through the car, while strategically placed service stations provide storage for cutlery, condiments, table service items, and waste. This allows crew to serve passengers smoothly and efficiently without unnecessary trips to the galley.





LOUNGE

Where Tradition Meets Inclusivity

Inspired by Amtrak's iconic observation and lounge cars, the new long-distance trains introduce a modern lounge designed for passengers to connect, relax, and enjoy the journey. Expansive windows frame panoramic views, while the fully accessible layout creates an inclusive space for everyone. A

beverage station provides a natural place to pause and socialize. The lounge continues the legacy of memorable journeys, bringing passengers together and celebrating the experience of travel.



25-FD-04111

000004271

UNCLASSIFIED

4/20/2018

THE SOCIAL HUB

The lounge offers a variety of seating settings designed to support different ways of using the space. Booth seating, long sofas, and open lounge areas allow passengers to choose between privacy and social interaction, while integrated power, coffee tables, and clear accessible pathways support comfort and convenience. The result is a welcoming, flexible environment where passengers can relax, connect, and enjoy the journey



HERO THE VIEW

In the lounge car, the view takes center stage. Expansive windows and skylights frame panoramic vistas of the American landscape, filling the space with natural light and a strong connection to the journey outside. The architecture and interior layout are carefully arranged to keep sightlines open, ensuring passengers can enjoy the scenery from every seat.



25-FDI-0416 000000271 "UNCLASSIFIED" 4/20/2016

25-FD-10416 0000004271 "UNCLASSIFIED" 4/20/2018



CX VISION | LOUNGE



A WELCOMING RETREAT

The lounge car is designed to transform throughout the journey. Natural light, adjustable blinds, and carefully balanced lighting shift the atmosphere from bright and open by day to warm and relaxed in the evening, creating a comfortable space to unwind, connect, or simply enjoy the view.



CAFFE

Savor the Journey

The Cafe is more than just a place to purchase refreshments; it's a destination for passengers to explore and unwind during their Amtrak long-distance journey.

Its welcoming, accessible counter, bold geometric design, and patterned wall finishes create a contemporary coffeehouse aesthetic.

Striking feature lights set the ambiance, while digital menu screens offer up-to-date information.

The thoughtful design ensures an attractive and passenger-friendly experience while maintaining an efficient space for the crew to work.



26-FD-04119

000002671

UNCLASSIFIED

CP0025

CAFE COUNTER

The café features a spacious open counter at an accessible height, creating a welcoming and passenger-friendly point of service. The counter is intentionally kept clear of equipment to support future food service options such as grab-and-go. Digital menu screens, positioned at queuing and point-of-purchase locations, connect to live data to provide up-to-date menus, promotions, and passenger information.



25-F-01015 000000271 "UNCLASSIFIED" 4/20/24

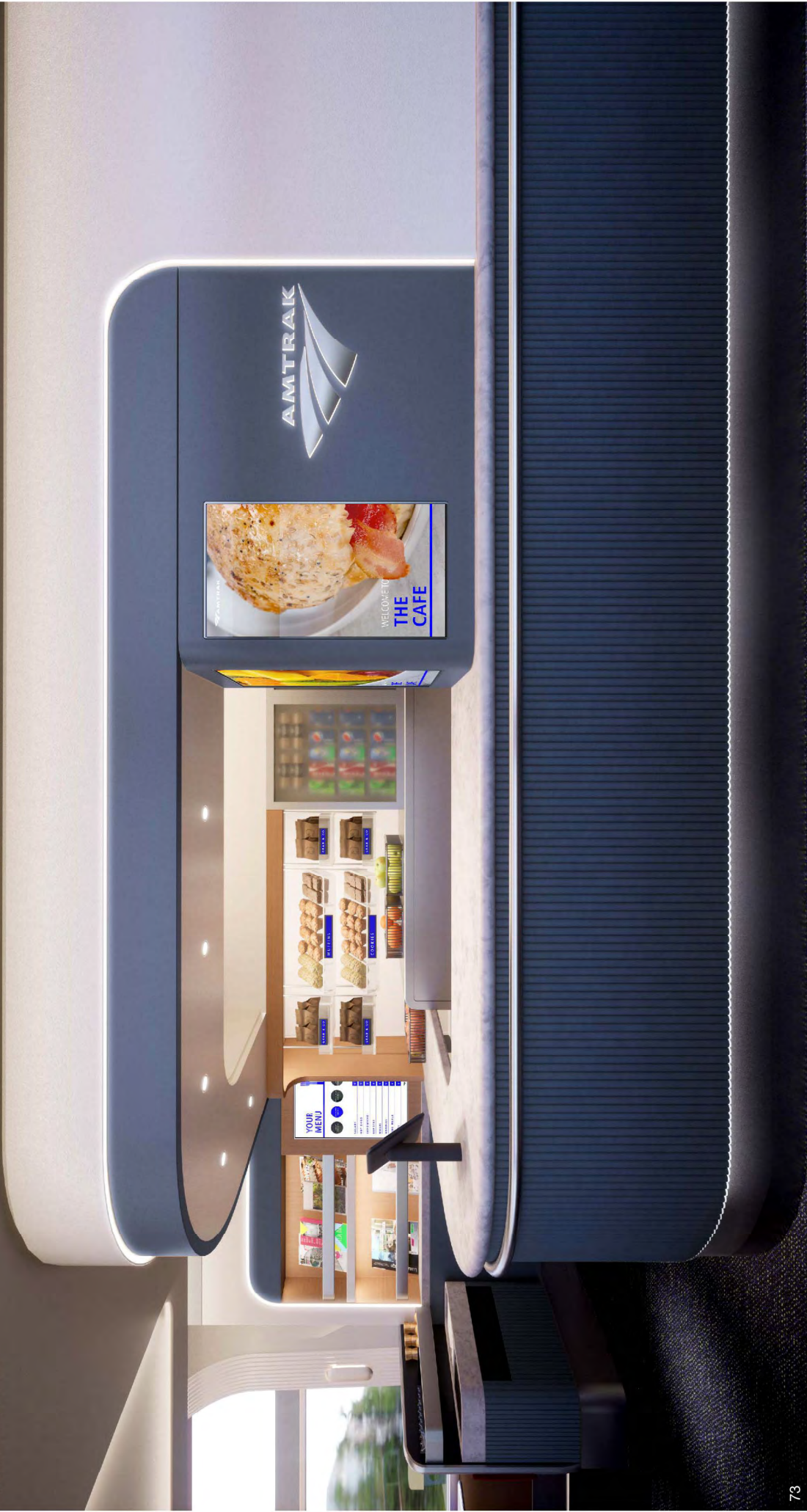

OPTIMIZED OPERATION

The back-of-house design follows a forward-thinking, modular approach that allows equipment to be upgraded or reconfigured as service models evolve. Equipment is arranged to support efficient and safe staff operation.

Areas closest to passengers are designed with a premium aesthetic to support point-of-purchase sales. Visual merchandising and food displays are carefully positioned to highlight fresh, appetizing options.



24-FOI-00416 0000002771 "UNCLASSIFIED" 4/20/2018

EQUITABLE EXPERIENCE

The seating in the Cafe has been thoughtfully designed with premium finishes, mirroring the quality and comfort found in the Diner while also providing a fully accessible space. This means our coach customers can experience the same levels of luxury and relaxation while enjoying their journey without exceeding their budget.

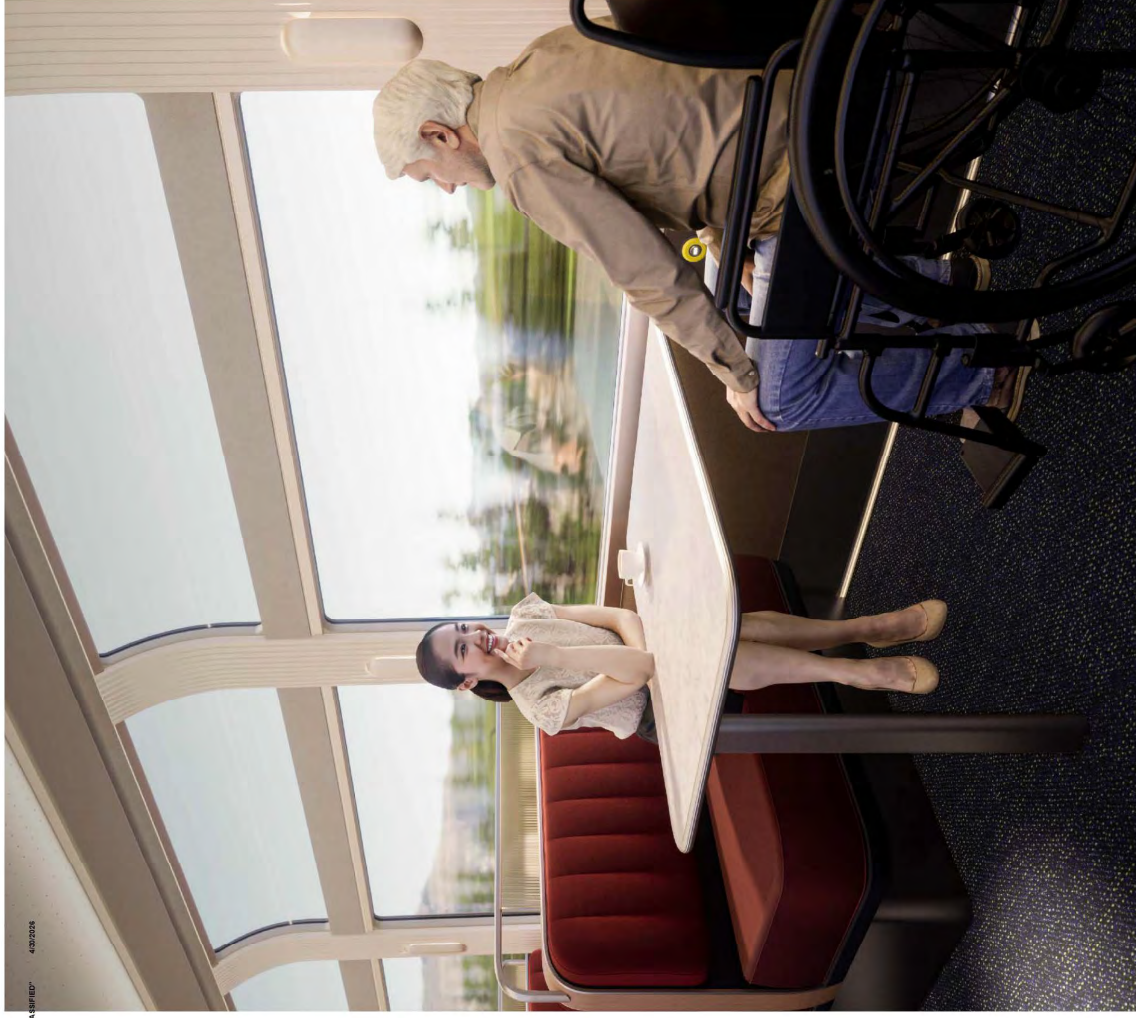



TOILETS & SHOWERS

Ensuring Refreshing Comfort for Your Journey

A range of thoughtfully designed restrooms and showers have been designed on board to ensure that every passenger's needs are met with comfort and convenience. Our commitment to passenger

satisfaction is reflected in the carefully curated design of each facility, ensuring a refreshing and comfortable experience throughout your journey.



Accessible
Toilet Room



Shower &
Changing Room

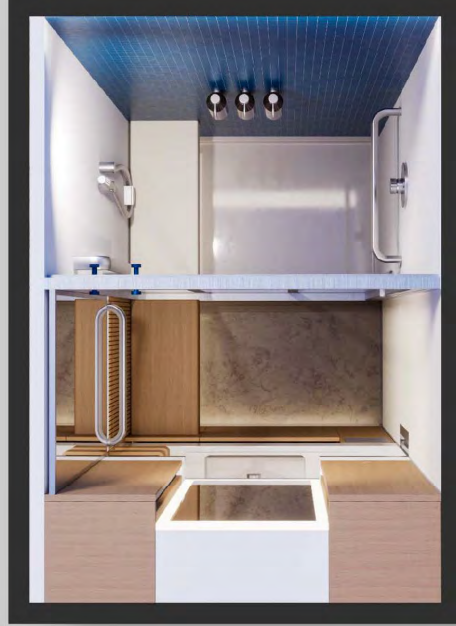

Standard
Toilet Room

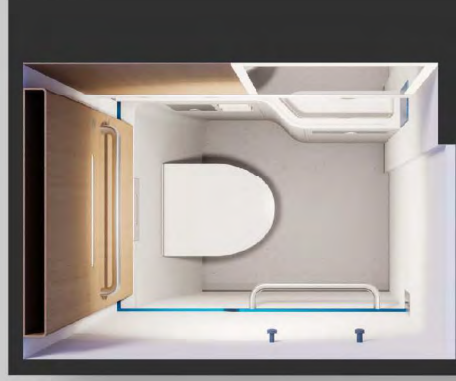

ACCESSIBLE TOILET ROOM

Our Accessible Toilet Room, optimized for people who use wheelchairs and for our customers with diverse accessibility needs, offers a spacious and inclusive experience.





4-202024

UNCLASSIFIED



25-FDI-00416 0000004271

CX VISION | ATR

STANDARD TOILET ROOM

Our Standard Toilet Room facilities provide a modern bathroom look and feel, featuring a toilet, sink and vanity area, compact yet stylish.





SHOWER & CHANGING ROOM

First class customers can indulge in our shower and changing room, boasting a beautifully appointed shower accompanied by a vanity area and a dedicated changing space.



25-F01-00415 0000008271 4-20-2024

"UNCLASSIFIED"

CX VISION | SHOWER & CHANGING ROOM



25-FD-00415 0000000271

"INCLASIFIED" 4.20.2024







CREW QUARTERS

Where the Heartbeat of Amtrak Resides.

Recognizing the pivotal role our crew plays in ensuring a seamless travel experience, we've crafted crew car that is purpose-built for the extended periods our crew spends on our trains. Our new trains will boast a crew rest area equipped with crew lockers, seating and a kitchenette, creating a

space specifically designed to prioritize their well-being.

At Amtrak, we value our crew, and our Crew Quarters reflect our commitment to their satisfaction and overall quality of life on the rails.

25-FD-05118

0000004271

"UNCLASSIFIED"

4/20/2024



CREW REST

A designated crew rest area will provide a space for socializing, fostering camaraderie among staff, while a small private kitchen allows them to prepare meals and unwind during well-deserved breaks.





AMTRAK | AMTRAK | AMTRAK | AMTRAK

Thank you.